

*** ARMY TM 9-2805-262-14
AIR FORCE TO 38G2-90-1
NAVY NAVFACP-8-613-14E**

TECHNICAL MANUAL

**OPERATOR, UNIT, DIRECT SUPPORT AND
GENERAL SUPPORT MAINTENANCE MANUAL**

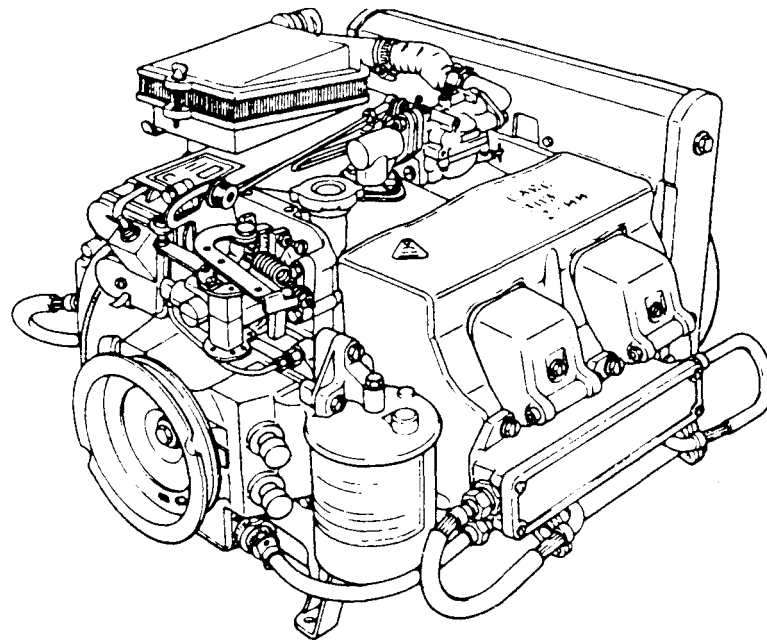

**ENGINE GASOLINE, 6 HP
MILITARY STANDARD MODELS
(MODEL 4A032-1, NSN 2805-00-776-0483)
(MODEL 4A032-2, NSN 2805-00-068-7512)
(MODEL 4A032-3, NSN 2805-01-139-0596)
(MODEL 4A032-4, NSN 2805-01-276-5946)**

Approved for public release; distribution is unlimited

* This manual supersedes TM 9-2805-203-14/TO 38G2-90-1/NAVFACP-8-813-14E,
28 September 1990, including all changes

**HEADQUARTERS, DEPARTMENTS OF THE ARMY,
THE AIR FORCE, AND THE NAVY
30 SEPTEMBER 1991**

WARNING

Drycleaning solvent, PD-680 used to clean parts is potentially dangerous to personnel and property. Avoid repeated and prolonged skin contact. Do not use near open flame or excessive heat. Flash point of solvent is 100°F -138°F (38°C-60°C).

WARNING

Serious eye injury can result from the starter rope knot. Wear eye protection when pull starting engine.

Before starting engine or operating any of the components insure that no loose bars, tools, or parts are lying in or on any part of the equipment, as they could cause serious damage to equipment or bodily injury to personnel.

Never wear loose clothing, or hanging appendages from person or clothing, while inspecting running engine, moving shafts, or like machinery.

WARNING

If operating the engine or equipment indoors insure that proper ventilation is provided. Carbon monoxide fumes are a colorless, odorless and deadly gas. These gases could cause permanent brain damage or death, if highly concentrated in any certain area. The symptoms are headache, dizziness, loss of muscular control, apparent drowsiness and coma. If exposure symptoms exist, move afflicted person or personnel to properly ventilated area and provide artificial respiration, if necessary.

WARNING

Always provide metal-to-metal contact between fuel container and fuel tank, while refueling, to avoid igniting fuel vapors with a static spark.

Do not refuel while engine is in operation.

Before refueling, insure that adequate fire fighting equipment is serviceable and is standing by for immediate use in event of fire or explosion.

During engine operation, proper fire fighting equipment should be serviceable and kept near in the event that fire is developed by electrostatic spark or detonation of the gas fumes. Do not smoke or use an open flame in the vicinity of these gasoline vapor hazards.

WARNING

Never touch engine or engine accessories with bare hands during operation, or before they have cooled sufficiently. Severe burns can be caused through carelessness.

WARNING

Do not touch the ignition system harness during starting or while in operation. Severe shocks or burns could result, and personnel may be seriously injured.

Disconnect the spark plug cables prior to engine maintenance to prevent accidental starting and severe shock.

WARNING

Operation of the equipment presents a noise hazard to personnel in the area. The noise level exceeds the allowable limits for unprotected personnel. Wear ear muffs or ear plugs which were fitted by a trained professional.

WARNING

Use extreme care when removing coil clamps. Flying clamps can cause serious eye injury. Cover work area with rag or hand when removing clamps.

CHANGE
NO. 3

HEADQUARTERS
DEPARTMENTS OF THE ARMY, THE AIR FORCE AND THE NAVY
WASHINGTON, D.C., 30 April 1997

**Operator, Unit, Direct Support and General Support
Maintenance Manual**

**ENGINE, GASOLINE, 6 HP,
MILITARY STANDARD MODELS
(MODEL 4A032-1, NSN 2805-00-776-0483)
(MODEL 4A032-2, NSN 2805-00-068-7512)
(MODEL 4A032-3, NSN 2805-01-139-0596)
(MODEL 4A032-4, NSN 2805-01-276-5946)**

DISTRIBUTION STATEMENT A: Approved for public release; distribution is unlimited

TM 9-2805-262-14/TO 38G2-90-1/NAVFAC P-8-613-14E, 30 September 1991, is changed as follows:

1. Remove and insert pages as indicated below. New or changed text material is indicated by a vertical bar in the margin. An illustration change is indicated by a miniature pointing hand.

Remove pages
i and ii

Insert pages
i and ii
F-1/F-2 Blank

2. Retain this sheet in front of manual for reference purposes.

ARMY TM 9-2805-262-14
AIR FORCE TO 38G2-90-1
NAVY NAVFAC P-8-613-14E
C3

By Order of the Secretaries of the Army, Air Force, and the Navy:

Official: 

JOELB.HUDSON
*Administrative Assistant to the
Secretary of the Army*
03559

DENNIS J. REIMER
*General, United States Army
Chief of Staff*

RONALD R. FOGELMAN
*General, USAF
Chief of Staff*

HENRY VICCELLIO, JR.
*General, USAF
Commander, Air Force Materiel Command*

J.E. BUFFINGTON
*Rear Admiral, CEC, US Navy
Commander
Navy Facilities Engineering
Command*

DISTRIBUTION:

To be distributed in accordance with DA Form 12-25E, block no. 5477, requirements for TM 9-2805-262-14.

CHANGE

NO. 2

HEADQUARTERS, DEPARTMENTS OF
THE ARMY, AIR FORCE, AND THE NAVY
WASHINGTON, D.C., 30 AUGUST 1996

Operator, Unit, Direct Support, and General Support
Maintenance Manual

**ENGINE, GASOLINE, 6 HP,
MILITARY STANDARD MODELS
(MODEL 4A032-1, NSN 2805-00-776-0483)
(MODEL 4A032-2, NSN 2805-00-068-7512)
(MODEL 4A032-3, NSN 2805-01-139-0596)
(MODEL 4A032-4, NSN 2805-01-276-5946)**

DISTRIBUTION STATEMENT A: Approved for public release; distribution is unlimited

TM 9-2805-262-14/TO 38G2-90-1/NAVFAC P-8-613-14E, 30 September 1991 is changed as follows:

1. Remove and insert pages as indicated below. New or changed text material is indicated by a vertical bar in the margin. An illustration change is indicated by a miniature pointing hand.

Remove pages	Insert pages
i through iv	i through iv
v and 1-0	v and 1-0
1-1 and 1-2	1-1 and 1-2
5-5 and 5-6	5-5 and 5-6
5-55 and 5-56	5-55 and 5-56
-----	5-56.1 and 5-56.2
6-3 and 6-4	6-3 and 6-4
6-25 through 6-29/(6-30 blank)	6-25 through 6-27/(6-28 blank)
B-11 and B-12	B-11 and B-12
Index 1 and Index 2	Index 1 and Index 2

2. Retain this sheet in front of manual for reference purposes.

By Order of the Secretaries of the Army, Air Force, and Navy:

Official:

DENNIS J. REIMER
General, United States Army
Chief of Staff

JOEL B. HUDSON
Administrative Assistant to the
Secretary of the Army
02237

Official:

RONALD R. FOGELMAN
General, USAF
Chief of Staff

HENRY VICCELLIO, JR.
General, USAF
Commander, Air Force Materiel Command

J. E. BUFFINGTON
Rear Admiral, CEC, US Navy
Commander
Navy Facilities Engineering
Command

DISTRIBUTION:

To be distributed in accordance with DA Form 12-25-E, block no. 5477, requirements for TM 9-2805-262-14.

CHANGE
NO. 1

HEADQUARTERS
DEPARTMENTS OF THE ARMY, AIR FORCE, AND NAVY
WASHINGTON, D. C., 25 NOVEMBER 1992

Operator, Unit, Direct Support and General Support
Maintenance Manual

ENGINE, GASOLINE, 6 HP
MILITARY STANDARD MODELS
(MODEL 4A032-1 , NSN 2805-00-776-0483)
(MODEL 4A032-2, NSN 2805-00-068-7512)
(MODEL 4A032-3, NSN 2805-01-139-0596)
(MODEL 4A032-4, NSN 2805-01-276-5946)

Approved for public release; Distribution is unlimited

TM 9-2805-262-14-0 35G2-90-1/NAVFAC P-8-613-14E, 30 September 1991 is changed as follows:

1. Remove and insert pages as indicated below. New or changed text material is indicated by a vertical bar in the margin. An illustration change is indicated by a miniature pointing hand.

Remove pages

iii and iv
4-5 and 4-6
4-37 through 4-40

Insert pages

iii and iv
4-5 and 4-6
4-37 through 4-40

2. Retain this sheet in front of manual for reference purposes.

**ARMY TM 9-2805-262-14
AIR FORCE TO 35G2-90-1
NAVY NAVFAC P-8-613-14E**

By Order of the Secretaries of the Army, Air Force, and Navy:

o f f i c i a l :

GORDON R. SULLIVAN
General, United States Army
Chief of Staff

MILTON H. HAMILTON
Administrative Assistant to the
Secretary of the Army
02997

MERRILL A. McPEAK
General, USAF
Chief of Staff

Official:

RONALD W. YATES
General, USAF
Commander Air Force Materiel Command

DAVID E. BOTTORFF
Rear Admiral, CEC, US Navy
Commander
Navy Facilities Engineering Command

DISTRIBUTION:

**To be distributed in accordance with DA Form 12-25-E, block no. 5477, requirement for
TM 9-2805-262-14.**

TECHNICAL MANUAL

HEADQUARTERS, DEPARTMENTS OF
THE ARMY, AND THE AIR FORCE, AND
THE NAVY, WASHINGTON, D.C.
30 SEPTEMBER 1991

NO. 2

**OPERATOR, UNIT, DIRECT SUPPORT, AND
GENERAL SUPPORT MAINTENANCE MANUAL
FOR
ENGINE, GASOLINE, 6 HP
MILITARY STANDARD MODELS**

**(MODEL 4A032-1, NSN 2805-00-776-0483)
(MODEL 4A032-2, NSN 2805-00-068-7512)
(MODEL 4A032-3, NSN 2805-01-139-0596)
(MODEL 4A032-4, NSN 2805-01-276-5946)**

REPORTING ERRORS AND RECOMMENDING IMPROVEMENTS

You can help improve this manual. If you find any mistakes, or if you know of a way to improve these procedures, please let us know. Mail your letter or DA Form 2028 (Recommended Changes to Publications and Blank Forms), or DA Form 2028-2 located in the back of this manual directly to: Commander, US Army Aviation and Troop Command, ATTN: AMSAT-I-MP, 4300 Goodfellow Blvd., St. Louis, MO 63120-1798. You may also submit your recommended changes by E-mail directly to <mpmt%/avma28@st-louis-emh7.army.mil>. A reply will be furnished directly to you. Instructions for sending an electronic 2028 may be found at the back of this manual immediately preceding the hard copy 2028.

For the Air Force, submit AFTO Form 22 (Technical Order System Publication Improvement Report and Reply) in accordance with paragraph 6-5, Section VI, T.O. 00-5-1. Forward directly to Commander, San Antonio, Air Logistics Center, ATTN: SA-ALC/TILD, 485 Quentin Roosevelt Road, Kelly AFB, TX 78241-6421

For the Navy, mail comments to Commanding Office, NCBC, 100 23rd Avenue, Building 800, Code: 6612TM, Port Hueneme, CA 93044-4400

DISTRIBUTION STATEMENT A: Approved for public release; distribution is unlimited

TABLE OF CONTENTS

	Page
CHAPTER 1 INTRODUCTION.....	1-1
Section I General Information	1-1
Section II Equipment Description and Data	1-2
Section III Principles of Operation	1-8
CHAPTER 2 OPERATING INSTRUCTIONS	2-1
Section I Description and Use of Operator's Controls and Indicators.....	2-1
Section II Preventive Maintenance Checks and Services	2-1
Section III Operation Under Usual Conditions	2-8
Section IV Operation Under Unusual Conditions	2-13

This manual supersedes TM 9-2805-203-144P/TO 38G2-90-1/NAVFAC P-8-613-14E, dated 28 September 1990, including all changes.

TABLE OF CONTENTS (cont)

CHAPTER 3	OPERATOR'S MAINTENANCE INSTRUCTIONS	3-1
Section I	Lubrication Instructions	3-1
Section II	Operator Troubleshooting Procedures	3-1
CHAPTER 4	UNIT MAINTENANCE	4-1
Section I	Repair Parts, Special Tools, Test, Measurement, Diagnostic Equipment (TMDE); and Support Equipment.....	4-1
Section II	Service Upon Receipt.....	4-2
Section III	Unit Preventive Maintenance Checks and Services (PMCS).....	4-2
Section IV	Unit Troubleshooting	4-3
Section V	Unit Maintenance Procedures	4-8
Section VI	Preparation for Shipment or Storage	4-106
CHAPTER 5	DIRECT SUPPORT MAINTENANCE INSTRUCTIONS	5-1
Section I	Repair Parts, Special Tools, Test, Measurement, Diagnostic Equipment (TMDE): and Support Equipment.....	5-1
Section II	Direct Support Troubleshooting.....	5-1
Section III	Direct Support Maintenance Procedures	5-5
CHAPTER 6	GENERAL SUPPORT MAINTENANCE INSTRUCTIONS	6-1
Section I	Repair Parts, Special Tools, Test, Measurement, Diagnostic Equipment (TMDE): and Support Equipment.....	6-1
Section II	General Support Troubleshooting	6-1
Section III	General Support Maintenance Procedures	6-3
APPENDIX A	REFERENCE	A-1
APPENDIX B	MAINTENANCE ALLOCATION CHART	B-1
APPENDIX C	COMPONENTS OF END ITEM AND BASIC ISSUE ITEMS	C-1
APPENDIX D	EXPENDABLE/DURABLE SUPPLIES AND MATERIALS LIST	D-1
APPENDIX E	TORQUE LIMITS	E-1
APPENDIX F	ADDITIONAL AUTHORIZATION LIST	F-1
INDEX	Index 1

LIST OF ILLUSTRATIONS

Figure Number	Title	Page
1-1	Military Standard Engine	1-0
1-2	Location and Description of Major Components Models4A032-1,-2	1-4
1-3	Location and Description of Major Components Mode14A032-3,-4	1-6
2-1	Operator'sControls and indicators	2-3
2-2	Starting Procedures	2-9
2-3	Stopping Procedures	2-10
4-1	Fuel Filter, Disassembly and Reassembly	4-11
4-2	AirCleaner, Service	4-13
4-3	AirCleaner, Removal and installation	4-15
4-4	Clamps and Ducts, Removal and installation	4-17
4-5	Air Cleaner Element, Removal and Installation	4-19
4-6	Service indicator, Replacement	4-21
4-7	Governor Control Rod, Adjustment	4-23
4-8	Governor Control Rod, Removal.	4-24
4-9	Governor Control Rod, Repair...	4-25
4-10	GovernorControl Rod, installation	4-26
4-11	OilTube, Replacement	4-27
4-12	Throttle Control Assembly, Replacement	4-29
4-13	Governor, Adjustment	4-31
4-14	Governor, Removal and installation	4-33
4-15	Fuel Line, Replacement	4-35
4-16	Air intake Elbow, Removai and installation	4-37
4-17	Carburetor,Adjustment	4-39
4-18	Carburetor, Removal and Inspection	4-41
4-19	Carburetor, installation	4-43
4-20	CarburetorAdapter, Replacement	4-45
4-21	High Tension Cables, Removal and Installation	4-47
4-22	Spark Plug, Removal and installation	4-49
4-23	Preheater, Removal and installation	4-51
4-24	Exhaust Manifold, Removal and installation	4-53
4-25	Relief Valve, Removal, inspection and installation	4-55
4-26	Rocker Box Cover, Removal and installation	4-57
4-27	Winterization Shroud, Removaland installation	4-59
4-28	CylinderHeadCove, internal Cover and Baffles, Removal,	4-61
4-29	Cylinder Head Cover, Internal Cover and Baffles, Installation	4-63
4-30	Oil Pan Cover, Removal and Installation	4-65
4-31	Top Cover, Removal and Installation	4-67
4-32	Fuel Pump, PressureTest	4-68
4-33	Fuel Pump, Replacement	4-69
4-34	Intake Manifold and Intake Manifold Hoses and Clamps, Removal, Inspection and installation	4-71
4-35	Intake Manifold Adapters, Removal and installation.....	4-73
4-36	Breather Box Cover and Breather Tube, Removal, Inspection and installation	4-75
4-37	Oil Filter(ElementFilter), Replacement	4-77

LIST OF ILLUSTRATIONS (cont)

Figure Number	Title	Page
4-38	Oil Filter (Spin on Filter), Replacement	4-79
4-39	Oil Filter Head, Removal and Installation	4-81
4-40	Starter Rope Pulley, Removal and Installation	4-83
4-41	Breaker Point Cover, Removal and Installation	4-85
4-42	Cover, Removal and Installation	4-87
4-43	Ignition Switch, Test	4-89
4-44	Ignition Switch, Removal and Installation	4-91
4-45	Condenser, Replacement	4-93
4-46	Coil Cover (Breaker Point Ignition), Removal and Installation	4-95
4-47	Coil Cover (Breakerless Ignition), Removal and Installation	4-97
4-48	Noise Suppression Filters, Removal and Installation	4-99
4-49	Breaker Points, Adjustment	4-101
4-50	Breaker Points. Removal and Installation	4-103
4-51	Ignition Timing. Adjustment	4-105
5-1	Compression Test	5-7
5-2	Cylinder Head, Removal	5-9
5-3	Cylinder Head, Repair	5-11
5-4	Cylinder Head, Installation	5-13
5-5	Valve, Adjustment	5-15
5-6	Rockers, Removal and Installation	5-17
5-7	Intake and Exhaust Valves, Removal and Installation	5-19
5-8	Rotating Magnet, Removal and Installation	5-21
5-9	Ignition Control Unit, Removal and Installation	5-23
5-10	Transformer, Removal and Installation	5-25
5-11	Ignition Module, Removal and Installation	5-27
5-12	Junction Box. Removal and Installation	5-29
5-13	Low Voltage Cable. Removal and Installation	5-31
5-14	Coil, Removal and Installation	5-33
5-15	Oil Pump Cover. Removal and Installation	5-35
5-16	Oil Pump Gears and Wear Plate, Removal and Installation	5-37
5-17	Oil Pan, Removal, Inspection, and Installation	5-39
5-18	Drain Tube, Replacement	5-41
5-19	Piston and Connecting Rod Assembly, Removal	5-43
5-20	Piston and Connecting Rod Assembly, Repair	5-45
5-21	Piston and Connecting Rod Assembly, Installation	5-47
5-22	Flywheel, Removal and Installation	5-49
5-23	Flywheel Housing and Protective Screen, Removal, Inspection and Installation	5-51
5-24	Oil Pressure Regulating Valve Assembly, Replacement	5-53
5-25	Oil Filler Tube and Gage, Replacement	5-55
5.25.1	Crankcase Oil Seal, Replacement	5-56.1
5-26	Electronic Ignition Wiring Diagram	5-59
5-27	Breaker Point Ignition System Wiring Diagram	5-60
6-1	Flywheel, Repair	6-5
6-2	Flywheel Housing, Repair	6-7
6-3	End Cover, Removal, Repair and Installation	6-9

LIST OF ILLUSTRATIONS (cont)

Figure Number	Title	Page
6-4	Crankshaft Bearing, Replacement	6-11
6-5	End Cover Oil Seal, Replacement.....	6-13
6-6	Camshaft, Camshaft Gear, Valve Tappets and Thrust Plate, Removal and Inspection	6-15
6-7	Camshaft, Camshaft Gear, Valve Tappets and Thrust Plate, Installation	6-17
6-8	Crankshaft and Center Main Bearing, Removal	6-19
6-9	Crankshaft and Center Main Bearing, Installation	6-21
6-10	Crankcase, Replace	6-23
6-11	Crankshaft Rear Bearing, Replacement.....	6-25
6-12	<i>Deleted</i>	

Change 2 v

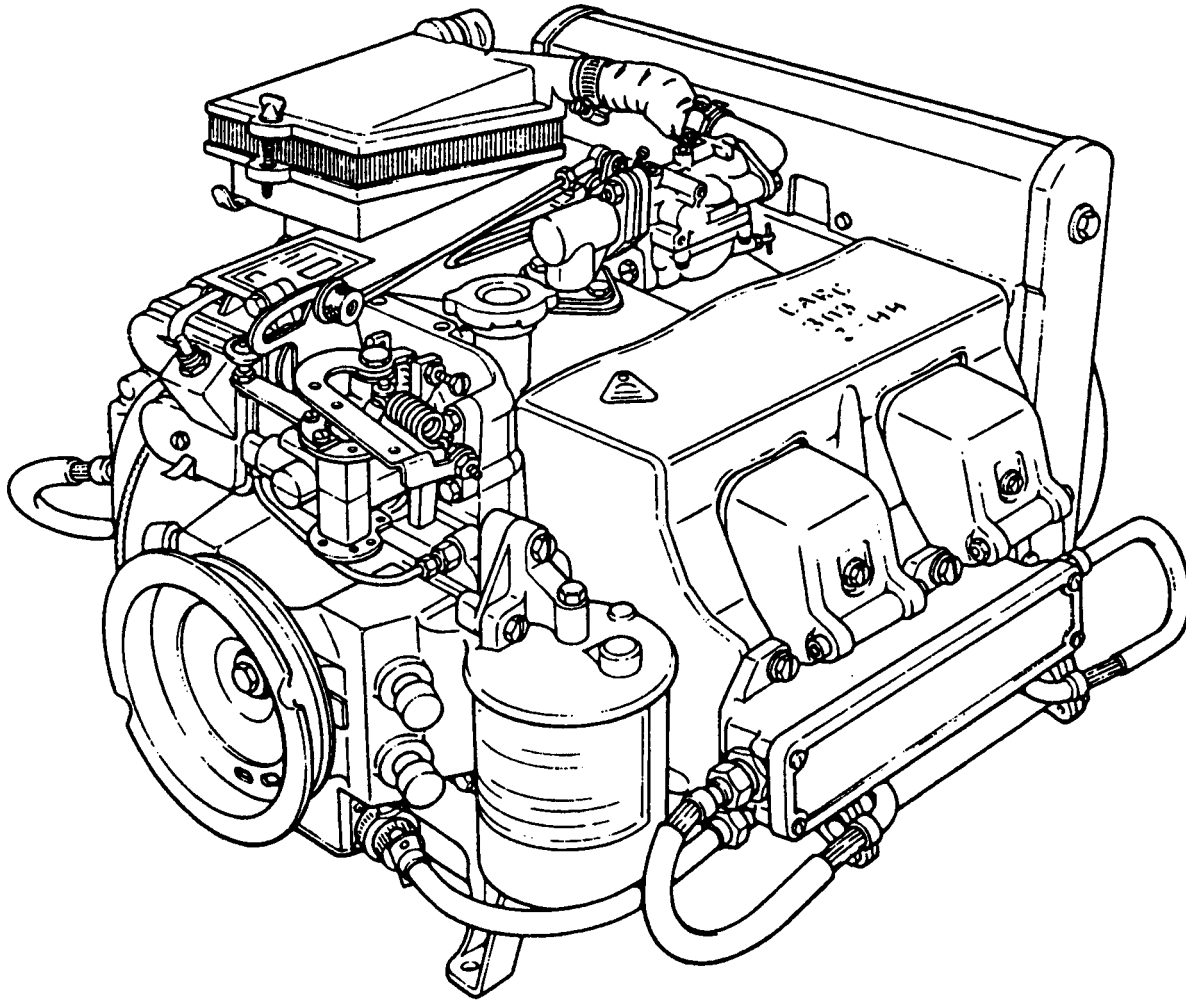

4868-001

Figure 1-1. Military Standard Engine.

CHAPTER 1

INTRODUCTION

	Page
OVERVIEW	1-1
Section I. General Information	1-1
Section II. Equipment Description and Data..	1-2
Section III. Principles of Operation	1-8

OVERVIEW

This chapter contains general information pertaining to 6HP Military Standard Engine and its components.

Section I. GENERAL INFORMATION

Paragraph	Page
1-1 Scope	1-1
1-2 Consolidated Index of Army Publications and Blank Forms	1-1
1-3 Maintenance Forms, Records, and Reports	1-1
1-4 Reporting Equipment Improvement Recommendations(EIR's)	1-2
1-5 Destruction of Army Materiel to Prevent Enemy Use	1-2
1-6 Preparation for Storage and Shipment	1-2
1-7 Glossary	1-2

1-1. Scope. This manual contains operator, unit, direct support and general support maintenance for the 6HP Military Standard Engine, Models 4A032-1, -2, -3, and -4 (figures 1-1, 1-2, and 1-3).

1-2. Consolidated Index of Army Publications and Blank Forms. Refer to the latest issue of DA PAM 25-30 to determine whether there are new editions, changes, or additional publications pertaining to the equipment

1-3. Maintenance Forms, Records and Reports.

a. Reports of Maintenance and Unsatisfactory Equipment. Department of the Army forms and procedures used for equipment maintenance will be those prescribed by DA Pam 738-750, as contained in Maintenance Management Update. Air Force personnel will use AFR 66-1 (Air Force Maintenance Management Policy) for maintenance reporting and TO-00-35D54 for unsatisfactory equipment reporting. Navy personnel will report maintenance performed utilizing the Maintenance Data Collection Subsystem (MDCS) IAW OPNAVINST 4790.2, Vol 3 and unsatisfactory material/conditions (UR submissions) IAW OPNAVINST 4790.2, Vol 2, chapter 17.

b. Reporting of Item and Packing Discrepancy. Fill out and forward SF 364 (Report of Discrepancy (ROD)) as prescribed in AR 735-1; I-JDL; R 414-1; ECNAVINST 4355.18/AFR 400-54.

c. Transportation Discrepancy Report (TDR) (SF 361). Fill out and forward Transportation Discrepancy Report (TDR) (SF 361) as prescribed in AR 55-28/NAVUSPINST 4610.33C/AFR 75-18/DLAR 4500.15.

1-4. Reporting Equipment Improvement Recommendations (EIR).

a. Army. If your Military Standard Engine needs improvement, let us know. Send us a EIR. You the user, are the only one who can tell us what you don't like about the equipment. Let us know why you don't like the design or performance. Put it on an SF 368 (Product Quality Deficiency Report). Mail it to us at: Commander, U.S. Army Aviation and Troop Command, ATTN: AMSAT-I-MDO, 4300 Goodfellow Boulevard, St. Louis, MO 63120-1798. We will send you a reply.

b. Air Force. Air Force personnel are encouraged to submit EIR's in accordance with AFR 900-4.

c. Navy. Naval personnel are encouraged to submit EIR's through their local beneficial suggestion pro-

1-5. Destruction of Army Materiel to Prevent Enemy Use. Refer to TM 750-244-3 for procedures to destroy equipment to prevent enemy use.

1-6. Preparation for Storage or Shipment. Refer to Chapter 4, Section VI, and TB 740-97-2 for procedures to place the equipment into storage.

1-7. Glossary. (Not applicable)

Section II. EQUIPMENT DESCRIPTION AND DATA

Paragraph		Page
1-8	Equipment Characteristics, Capabilities, and Features	1-2
1-9	Location and Description of Major Components (Models 4A032-1, -2)	1-3
1-10	Location and Description of Major Components (Models 4A032-3, -4)	1-5
1-11	Equipment Data.....	1-7
1-12	Differences Between Models.....	1-8
1-13	Safety, Care, and Handling	1-8

1-8. Equipment Characteristics, Capabilities, and Features. The Military Standard Engine is an air cooled, four cylinder, 4 cycle gasoline engine. The engine is capable of developing 6 H Pat 3600 RPM.

1-9. **Location and Description of Major Components (Models 4A032-1,-2)** (figure1-2).

- 1 Carburetor - Mixes air and fuel and delivers it to the engine
- 2 Air Cleaner - Cleans air going into the carburetor
- 3 Fuel Pump - Delivers fuel to carburetor
- 4 Oil Filter - Cleans engine oil
- 5 Governor - Regulates maximum speed of engine
- 6 Spark Plug - Delivers spark to air fuel mixture
- 7 Flywheel Fan - Provides air for cooling engine during operation
- 8 Oil Pan - Serves as a reservoir for engine oil
- 9 High Tension Cables - Delivers high voltage electrical charge to spark plug
- 10 Starter Rope Pulley - Provides area for starter rope to be attached to the engine when pull starting engine
- 11 Starter Rope - Used to pull start engine
- 12 Fuel Filter - Cleans fuel going to engine
- 13 Oil Gage and Filler Tube - Provides the means to check engine oil level and to add oil as needed.
14. Oil Pump - Pumps engine oil throughout engine for lubrication.
- 15 Throttle Control (Models 4A032-1, (serial nos. G001001–G004004), -2) - Adjusts engine speed from idle to full governed position.
- 16 Service Indicator - Indicates when air cleaner requires servicing
- 17 Ignition Switch - Terminates engine operation/allows engine to be started.
- 18 Winterization Shroud-Temperature operated, regulates cooling air to the engine.

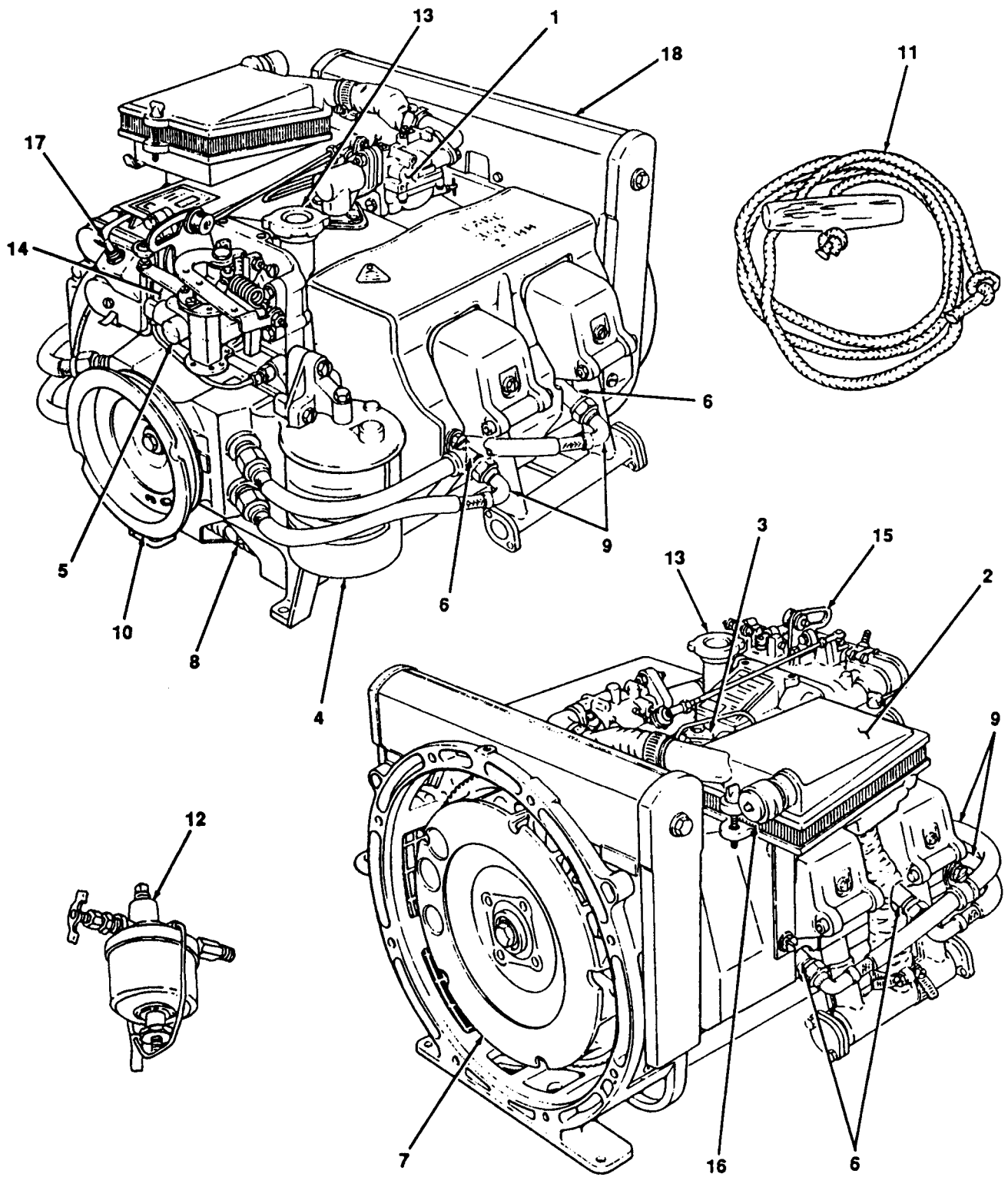

4868-002

Figure 1-2. Location and Description of Major Components Models 4A032-1, -2.

1-10. **Location and Description of Major Components (Models 4A032-3, -4)** (figure 1-3).

- 1 Carburetor - Mixes air and fuel and delivers it to the engine
- 2 Air Cleaner - Cleans air going into the carburetor
- 3 Fuel Pump - Delivers fuel to carburetor
- 4 Oil Pump - Pumps oil throughout engine for lubrication
- 5 Governor - Regulates maximum speed of engine
- 6 Ignition Control Unit - Regulates spark delivery to spark plug
- 7 Spark Plug – Delivers spark to air fuel mixture
- 8 Flywheel Fan - Provides air for cooling the engine during operation
- 9 High Tension Cables - Delivers high voltage electrical charge to spark plug
- 10 Starter Rope - Used to pull start engine
- 11 Starter Rope Pulley - Provides area for starter rope to be attached to engine when pull starting engine
- 12 Fuel Filter - Cleans fuel going to engine
- 13 Low Voltage Cables - Delivers control voltage to ignition control unit
- 14 Service Indicator - Indicates when air cleaner assembly requires servicing
- 15 Throttle Control - Adjusts engine speed from idle to full governed position
- 16 Oil Pan - Serves as reservoir for engine oil
- 17 Oil Gage and Filler Tube - Provides the means to check engine oil level and to add oil as needed
- 18 Ignition Switch - Terminates engine operation/allows engine to be started.
- 19 Oil Filter - Cleans engine oil.
- 20 Winterization Shroud - Temperature operated, regulates cooling air to the engine.

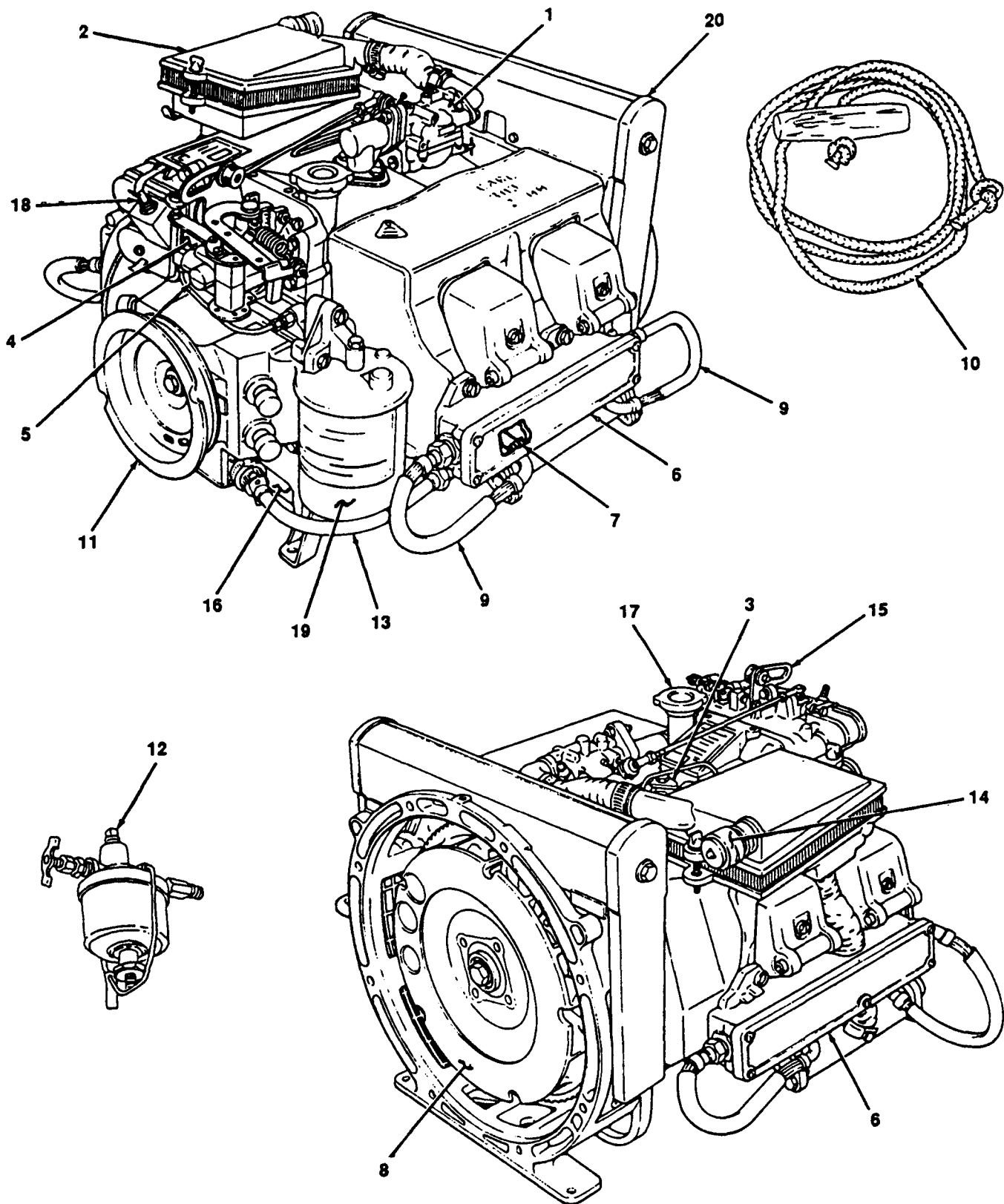

4868-003

Figure 1-3. Location and Description of Major Components Model 4A032-3, -4.

1-11. **Equipment Data.**

a. General.

Engine model4A032-1, -2, -3, and-4
 Type 4 cycle gasoline powered
 Number of cylinders4
 Horse power rating.6HP at 3600 r.p.m
 Firing order1-4-2-3
 Fuel pump Diaphragm 3.0-4.5 psi outlet pressure
 Aircleaner Dry element
 Spark plug Shielded
 Gap028-.033in. (.071-.083cm)
 Breakerpoints
 Gap016-.020in. (.040-.050cm)
 Valve tappet clearance cold007-.009 in. (.017-.027 cm)
 (Intake and exhaust)
 Governor Centrifugal
 Oil capacity (total) 2 1/8 quart models 4A032-1, -2, -3, -4
 (Oil filter)1/2 quart

b. Dimensions and Weight Model 4A032-1 (Serial Number G000001 through G000500)

Length 19.12 in. (48.58cm)
 Width 20.62 in. (51.12 cm)
 Height 13.87 in. (35.24cm)
 Weight 75lbs(33.75 kg)

c. Dimensions and Weight Model 4A032-1 (Serial Number G001001 through G004004).

Length 19.12 in. (48.58cm)
 Width 20.62 in. (52.39 cm)
 Height 15.75 in. (40.00 cm)
 Weight 83 lbs (37.35 kg)

d. Dimensions and Weight Model 4A032-2 - .

Length 27.25 in. (69.21 cm)
 Width 24.25 in. (61.59 cm)
 Height 18 in. (45.72 cm)
 Weight 110 lbs (49.5 kg)

e. Dimensions and Weight Model 4A032-3.

Length 27.25 in. (69.21 cm)
 Width 24.25 in. (61.59 cm)
 Height 18 in. (45.72 cm)
 Weight 110 lbs (49.5 kg)

f. Dimensions and Weight Model 4A032-4.

Length	27.25 in. (69.21 cm)
Width	24.25 in. (61.59 cm)
Height	18in. (45.72 cm)
Weight	110 lbs (49.5 kg)

1-12. **Differences Between Models.** All four models of the Military Standard are similar except for the following differences:

- a. Models 4A032-2, -3, -4 have dry element air cleaners with service indicators.
- b. Models 4A032-1 (serial nos. G000001 through G000500) is equipped with engine stop button.
- c. Model 4A032-1 (serial nos. G001001 through G004004), -2 -3, and -4 are equipped with an ignition switch.
- d. Models 4A032-1 and -2 are equipped with a breaker point ignition.
- e. Model 4A032-3, -4 is equipped with breakerless ignition.
- f. Models 4A032-1 (serial nos. G001001 through G004004), -2,-3, and -4 are equipped with a throttle control.

1-13. **Safety, Care, and Handling.** Observe all WARNINGS, CAUTIONS and NOTES in this manual. This equipment can be extremely dangerous if these instructions are not followed.

Section III. PRINCIPLE OF OPERATION

1-14. Principles of Operation.

a. General. The 6 HP Military Standard engine is a four cycle four cylinder, horizontally apposed, air cooled, gasoline powered internal combustion engine. The engine develops its full rated capacity at a governed 3600 r.p.m.

b. Simplified Principles of Operation. A starter rope pulley, provides a means to connect the starter rope for pull starting the engine. An inline fuel filter cleans the fuel supplied to the engine. The filter comes equipped with a fuel cutoff valve, that when closed, stops fuel flow to the engine. The engine comes equipped with dry element air cleaner. On models 4A032-2, -3, and -4 the air cleaner comes equipped with a service indicator. The service indicator signals when the element requires cleaning. The inlet temperature control varies the amount of unheated air entering the air cleaner. On model 4A032-1 (serial nos. G000001 through G000500) a stop button is used to terminate engine operation. On models 4A032-1 (serial nos. G001001 through G004004), -2, -3, and -4a two position ignition switch is used. When the switch is in the RUN position the engine can be started. Setting the switch to OFF terminates engine operation

c. Detailed Principles of Operation.

(1) *Fuel system.* The fuel system is composed of a fuel filter, fuel pump, fuel line, and carburetor. The fuel filter is a bowl type with a filtering screen. The screen filters dirt and other foreign materials from the fuel. The fuel pump draws fuel from an external fuel supply through the fuel filter, and delivers it to the carburetor. The fuel pump, a diaphragm type, is driven by the camshaft. The fuel pump can be operated manually, using the priming lever. This allows the fuel system, between the pump and the carburetor, to be primed before starting the engine. The carburetor mixes the air, from the air cleaner, and the fuel. This is then delivered to the combustion chamber where it is compressed and burned.

(2) *Cooling system.* The flywheel fan draws cool air into the winterization shroud, where it is then directed by the cylinder head covers, baffles, and oil pan cover. The airflows around the cylinders and cylinder head assemblies and cools the engine.

(3) *Air supply.* The air cleaner cleans the air going to the carburetor. The air cleaner uses a dry fiber element to remove dirt from the air. As the element gets dirty, airflow through it decreases and creates a vacuum in the air cleaner. When airflow decreases too much, the service indicator shows a red signal and indicates the element requires cleaning.

(4) *Speed regulation.* All four models of the engine are equipped with a centrifugal flyweight governor connected to the carburetor by a control rod. The governor determines the fastest speed at which the engine will run. Model 4A032-1 (serial nos. G000001 through G000500) has no speed regulation, other than the adjustment of the governor. Models 4A032-1 (serial nos. G001001 through G004004), -2, -3, and -4 are equipped with a throttle control which overrides the function of the governor. The throttle control allows the engine speed to be adjusted between idle and full governed speed.

(5) *Ignition system.* There are two different types of ignition systems used on the engine. Models 4A032-1 (all) and -2 use a breaker point ignition system. A set of breaker points triggers a condenser and coil to produce a high voltage electric charge. This charge is then delivered, through a shielded ignition cable, to the spark plug boated in the cylinder head. This charge creates a spark at the spark plug electrode, and ignites the air/fuel mixture in the combustion chamber. Model 4A032-3, -4 uses a breakerless ignition system. This system uses electronic components to generate the high voltage electric charge to ignite the air/fuel mixture.

(6) *Lubrication.* An oil pump, located behind breaker points, supplies lubricating oil to the internal components of the engine, cylinder head assemblies, and governor. The engine is equipped with a replaceable oil filter, which cleans the oil as the engine runs.

CHAPTER 2

OPERATING INSTRUCTIONS

	Page
OVERVIEW	2-1
Section I. Description and Use of Operator's Controls and indicators.....	2-1
Section II. Preventive Maintenance Checks and Services(PMCS)	2-4
Section III. Operation Under Usual Conditions	2-7
Section IV. Operation Under Unusual Conditions	2-11

OVERVIEW

This chapter contains instructions and procedures required to operate the engine safely and efficiently.

Section I. DESCRIPTION AND USE OF OPERATORS' CONTROLS AND INDICATORS

Paragraph	Page
2-1 General	2-1
2-2 Operator's Controls and indicators	2-1

2-1. General. This section contains a list of operator controls and indicators and a description of their use.

2-2. Operator's Control and Indicators. The following is a list of operator controls and indicators for all models of the 6HP Military Standard engine. Although the appearance of the engine may vary between models the location and function of the controls and indicators are similar (figure 2-1).

Key	Control or Indicator	Function
1	Choke	Used during engine start-up to reduce airflow through carburetor, making starting easier.
2	Air Cleaner Service Indicator	indicates to operator when air cleaner requires servicing.
3	Throttle Control Models 4A032-1 (serial nos. G001001 through G004004), -2, -3, -4	Allows operator to regulate speed of engine between idle speed and full governed speed.
4	Oil Filler Tube and Gage	Allows operator to check oil level in engine, and provides means for adding oil as needed.
5	Ignition Switch Models 4A032-1 (serial nos. G001001 through G004004), -2, -3, -4	Used to stop engine/allows engine to be started.

Key	Control or Indicator	Function
6	Engine Stop Button Model 4A032-1 (serial nos. G000001 through G000500)	Depressing button stops engine.
7	Starter Rope	Used to pull start engine.
8	Fuel Shutoff Valve	Stops fuel flow from fuel filter.
9	Starter Rope Pulley	Provides area for starter rope to be attached when pull starting engine.
10	Fuel Primer Lever (not on all models)	Used to prime fuel system.
11	Inlet Temperature Control Models 4A032-1 (serial nos. G001001 through G004004), -2,-3, -4)	Used to adjust amount of cold air entering air cleaner.

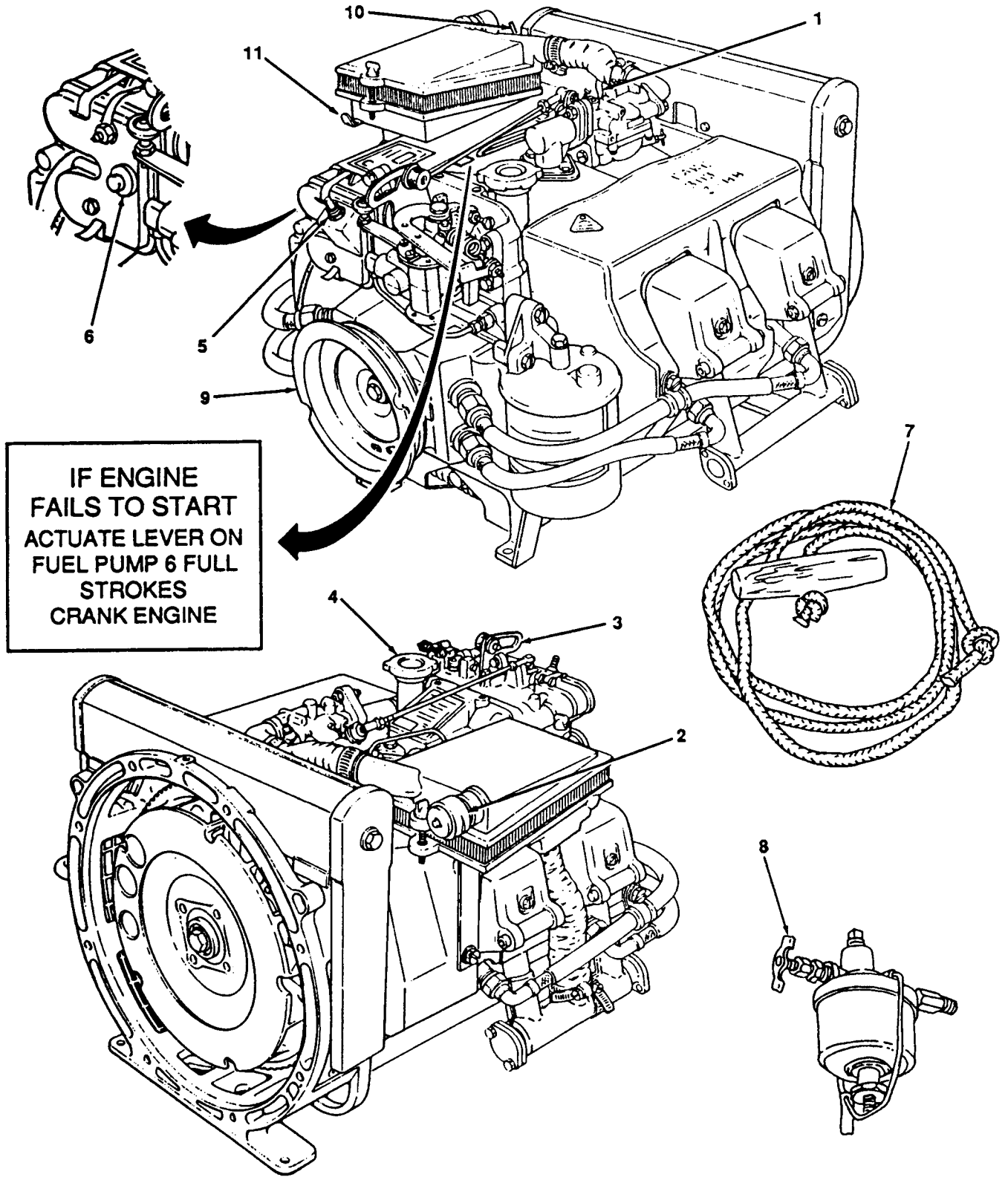

4868-004

Figure 2-1. Operator's Controls and Indicators.

Section II. PREVENTIVE MAINTENANCE CHECKS AND SERVICES (PMCS)

Paragraph	Page
2-3 General	2-4
2-4 Purpose of PMCS Table	2-4
2-5 Explanation of Columns	2-4
2-6 Equipment is Not Ready/Available If Column	2-4
2-7 Reporting Deficiencies	2-5
2-8 Special Instructions	2-5

2-3. **General.** Operator PMCS are performed to ensure that the engine is ready for operation at all times. Perform the checks and services at the specified intervals.

- a. Before you operate, perform your before (B) PMCS. Observe all CAUTIONS and WARNINGS.
- b. While you operate, perform your during (D) PMCS. Observe all CAUTIONS and WARNINGS.
- c. After you operate, be sure to perform your after (A) PMCS.
- d. If your equipment fails cooperate, refer to table 3-1 and report deficiencies on DA Form 2404.

2-4. **Purpose of PMCS Table.** The purpose of the PMCS table is to provide a systematic method of inspection and servicing the equipment. In this way, small defects can be detected early before they become a major problem causing the equipment to fail to complete its mission. The PMCS table is arranged with the individual PMCS procedures listed in sequence under assigned intervals. The most logical time (before, during, or after operation) to perform each procedure determines the interval to which it is assigned. Make a habit of doing the checks in the same order each time and anything wrong will be seen quickly. See paragraphs 2-5 and 2-6 for an explanation of the columns in table 2-1.

2-5. **Explanation of Columns.** The following is a list of the PMCS table column headings with a description of the information found in each column.

- a. Item No. This column shows the sequence in which the checks and services are to be performed, and is used to identify the equipment area on the Equipment Inspection and Maintenance Worksheet, DA Form 2404.
- b. Interval. This column shows a dot (•) when each check is to be done.
- c. Item to be Inspected/Procedures. This column identifies the general area or specific part where the check or service is to be done, the checks or services to be done, and explains how to do them.
- d. Equipment is Not Ready/Available If. See paragraph 2-6.

2-6. **Equipment is Not Ready/Available If Column.** This column lists conditions that make the equipment unavailable for use because it is unable to perform its mission, or because it would represent a safety hazard. Do not acceptor operate equipment with a condition in the "Equipment is Not Ready/Available If" column.

NOTE

The terms ready/available and mission capable refer to the same status: Equipment is on hand and is able to perform its combat mission. Refer to DA Pam 738-750.

2-7. Reporting Deficiencies. If any problem with the equipment is discovered during PMCS or while it is being operated that cannot be corrected at the operator/crew maintenance level, it must be reported. Refer to DA Pam 738-750 and report the deficiency using the proper forms.

2-8. Special Instructions. Preventive maintenance is not limited to performing the checks and services listed in the PMCS table.

NOTE

If the equipment must be kept in continuous operation, check and service only those items that can be checked and serviced without disturbing operation. Make the complete checks and services when the equipment can be shut down.

WARNING

Drycleaning solvent PD-680 used to clean parts is potentially dangerous to personnel and property. Avoid repeated and prolonged skin contact. Do not use near open flame or excessive heat. Flash point of solvent is 100°F - 138°F (38°C - 60°C).

a. Keep it clean. Dirt, grease, oil, and debris get in the way and may cover up a serious problem. Clean as you work and as needed. Use drycleaning solvent on all metal surfaces. Use soap and water to clean rubber or plastic material.

b. Bolts, Nuts, and Screw. Check them all for obvious looseness, missing, bent, or broken condition. You can't try them all with a tool, but look for chipped paint, bare metal, or rust around boltheads. If you find one you think is loose, tighten it, or report it to unit maintenance if you can't tighten it.

c. Electrical Wires and Cable Connectors. Look for bare wires, and loose or broken connectors. Report defects to unit maintenance.

d. Fluid Lines. Look for wear, damage, and leaks. Make sure clamps and fittings are tight. Wet spots and stains around a fitting or connector can mean a leak. If a leak comes from a loose connector, tighten it. If something is broken or worn out, report it to unit maintenance.

e. Leakage Definitions. It is necessary for you to know how fluid leakage affects the status of your equipment. The following are definitions of the types/classes of leakage you need to know to be able to determine the status of your equipment. Learn and be familiar with them. When in doubt, NOTIFY YOUR SUPERVISOR!

Leakage Definitions:

Class I	See page of fluid (as indicated by wetness or discoloration) not great enough to form drops.
Class II	Leakage of fluid great enough to form drops but not enough to cause drops to drip from item being checked/inspected.
Class III	Leakage of fluid great enough to form drops that fall from the item being checked/inspected.

CAUTION

Equipment operation is allowable with minor leakage (Class I or II) of any fluid except fuel. Of course, consideration must be given to the fluid capacity in the item being checked inspected. When in doubt, notify your supervisor.

When operating with Class I or II leaks, continue to check fluid level more often than required in the PMCS. Parts without fluid will stop working and/or cause equipment damage.

Class III leaks should be reported to your supervisor or unit maintenance.

f. Painting. Touch-up engine as needed. Refer to TM 43-0139 for specific painting procedures.

Table 2-1. Operator Preventive Maintenance Checks and Services (PMCS).

NOTE

If the equipment must be kept in continuous operation, check and service only those items that can be checked and serviced without disturbing operation. Make the complete checks and services when the equipment can be shut down.

Item No.	Interval			Item to be Inspected Procedure	Equipment is Not Ready/Available If
	B	D	A		
1	•			ENGINE a. Visually inspect engine for signs of damage or missing parts. b. Inspect engine for evidence of fuel or oil leaks. c. Check fuel filter for evidence of fuel contamination and notify unit maintenance if present. d. Perform lubrication on engine. Refer to LO 9-2805-262-12 for lubrication instructions. e. Listen to engine for unusual sounds, rough running, or excessive exhaust smoke.	Class III oil leak, or Class I fuel leak is detected.

Table 2-1. Operator Preventive Maintenance Checks and Services (PMCS) (cont).

Item No.	Interval			Item to be Inspected Procedure	Equipment is Not Ready/Available If
	B - Before	D - During	A - After		
2	•	•	•	AIR CLEANER SERVICE INDICATOR Check indicator, and notify unit maintenance when indicator is in the red area.	Indicator is in the red area.
3	•			STARTER ROPE ASSEMBLY Inspect starter rope for cuts or signs of fraying.	

Section III. OPERATION UNDER USUAL CONDITIONS

Paragraph		Page
2-9	Starting Procedure	2-7
2-10	Stopping Procedures	2-8

2-9. Starting Procedures. (figure 2-2)

- a. Open fuel shutoff valve (1) on fuel filter (2).
- b. Rotate choke control lever (3) counterclockwise and close choke.
- c. On models 4A032-1 (serial nos. G001001 through G004004), -2, -3, -4 place throttle control (4) approximately 1/4 in. from idle position.
- d. On models 4A032-1 (serial nos. G001001 through G004004), -2, -3, -4 set ignition switch (5) to RUN position.
- e. On models 4A032-1 (serial nos. G001001 through G004004), -2, -3, -4 set inlet temperature control as follows:
 - (1) Above 50°F (10°C) set handle (6) to SUMMER position.
 - (2) Between 50-25°F (10° (-4)°C), place handle (6) in center position.
 - (3) Below 25° (-4°C) set handle (6) to WINTER position.

WARNING

Operation of the equipment presents a noise hazard to personnel in the area. The noise level exceeds the allowable limits for unprotected personnel. Wear ear muffs or ear plugs which were fitted by a trained professional.

Serious eye injury can result from the starting rope knot. Wear eye protection when pull starting engine.

- f.* Wind starter rope (7) clockwise around starter pulley (8) and pull briskly.
- g.* When the engine has started, rotate the choke control lever (3) clockwise until the choke is fully opened, and the engine will continue to run.

NOTE

It maybe necessary on models 4A032-1 (serial nos. G001001 through G004004), -2, -3, -4 to rotate the throttle control counterclockwise to obtain a smooth idle.

- h.* Allow engine to warm-up for at least 3 minutes before applying load.
- i.* On models 4A032-1 (serial nos. G001001 through G004004), -2, -3, -4 after warm-up, move throttle control counterclockwise to the full governed position.
- j.* Apply end item load. Refer to End Item Operators Manual.

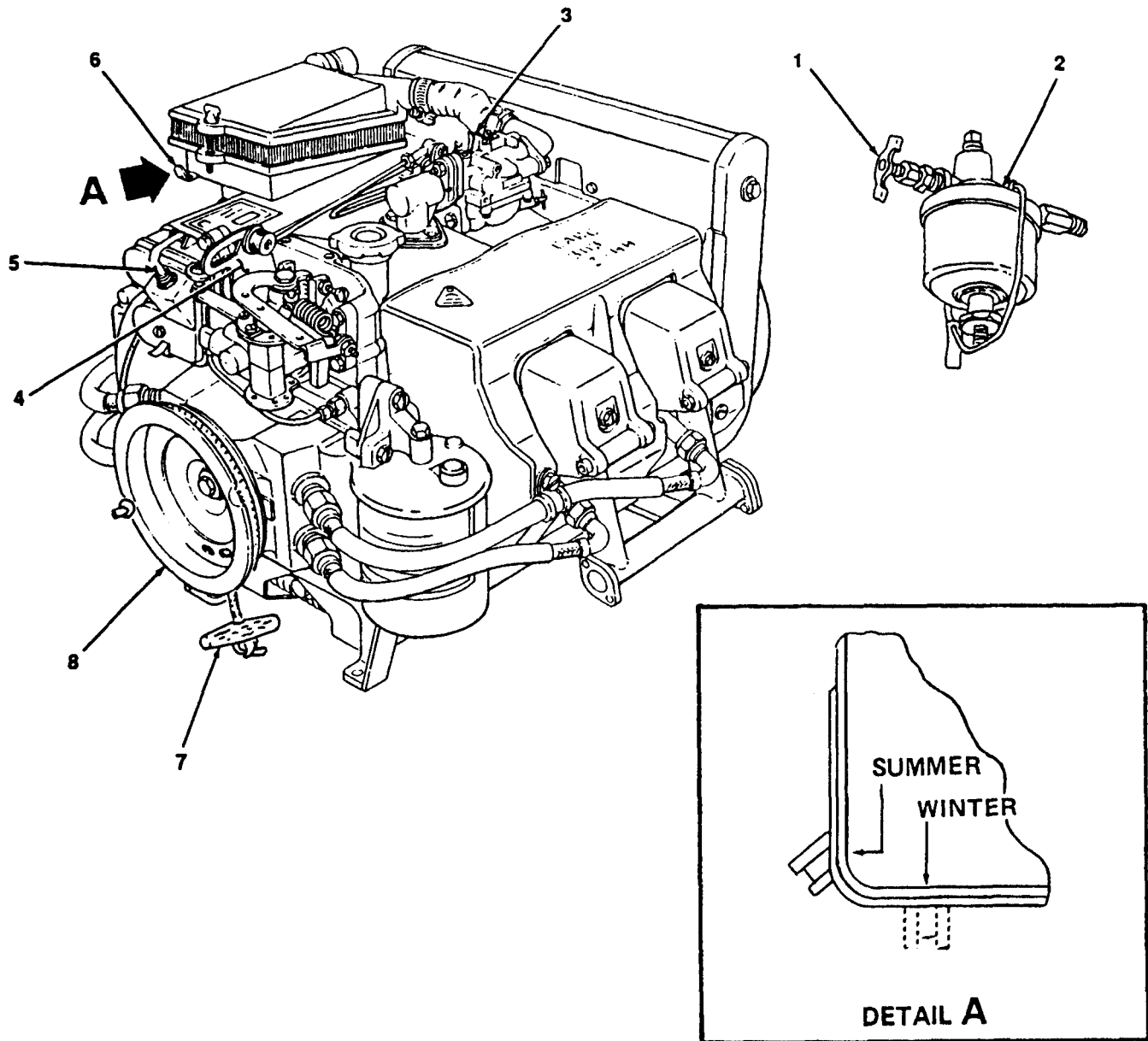

4868-005

Figure 2-2. Starting Procedures.

2-10. **Stopping Procedures.** (figure 2-3)

- a. Remove end item load. Refer to End Item Operators Manual.
- b. On models 4A032-1 (serial nos. G001001 through G004004), -2, -3, -4 move throttle control (1) to idle position, and let engine idle for at least 2 minutes.
- c. On model 4A032-1 (serial nos. G000001 through G000500) press engine stop button (2), on models 4A032-1 (serial nos. G001001 through G004004), -2, -3, -4 set ignition switch (3) to OFF.

- d. Close fuel shutoff valve (4) on fuel filter (5).
- e. Perform After Operation PMCS.

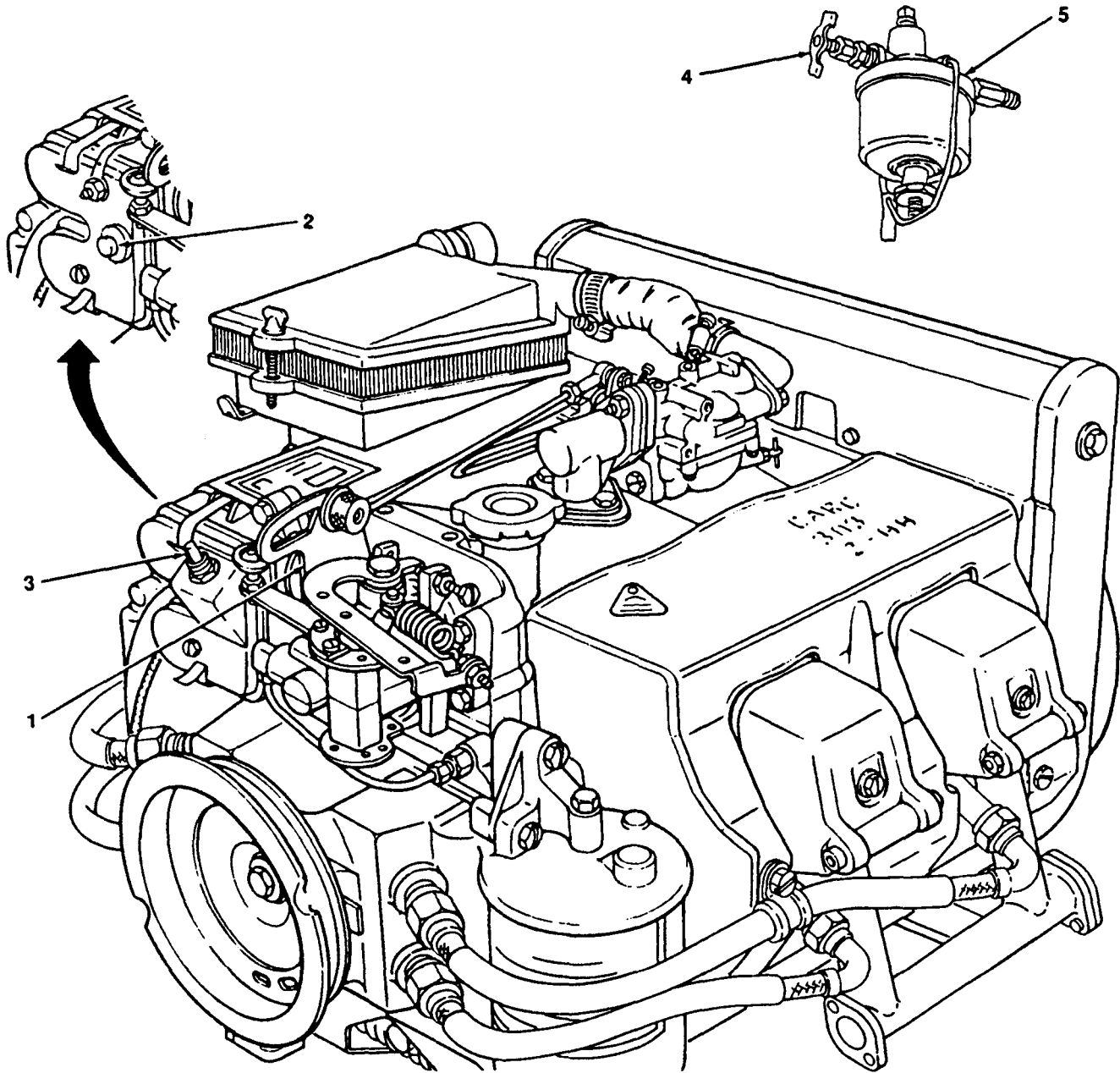

Figure 2-3. Stopping Procedures.

4868-006

Section IV. OPERATION UNDER UNUSUAL CONDITIONS

Paragraph		Page
2-11	Operation in Dusty or Sandy Areas.....	2-11
2-12	Operation in Rainy, Humid, or Salt Air Conditions	2-11
2-13	Operation in Extreme Heat	2-11
2-14	Operation at Different Altitudes	2-11
2-15	Operation in Extreme Cold	2-12

2-11. **Operation in Dusty or Sandy Areas.** The procedures for operating the engine are the same as under usual conditions except for the following special precautions:

- a. Keep fuel, lubrication, ignition and cooling systems free of dust and sand.
- b. Check aircleaner indicator more often when operating in dusty or sandy areas. Have unit maintenance service air cleaner element as needed.
- c. In the event of severe dust or sand storms, provide a well protected sheltering device for the engine.
- d. Remove all dust or sand from the engine and inspect for damage.

2-12. **Operation in Rainy, Humid, or Salt Air Conditions.** The procedures for operating the engine are the same as under usual conditions except for the following special precautions:

- a. Remove all visible signs of corrosion as soon as possible.
- b. Keep fuel lines, and ignition lines as dry as possible.
- c. If possible, store engine indoors.
- d. Use a thin layer of oil or desiccants to keep corrosion to a minimum.

2-13. **Operation in Extreme Heat.** The procedures for starting and operating are the same as under usual conditions except for the following special precautions:

- a. Check oil level more often when operating in extreme heat.
- b. Use appropriate grade oil per LO 9-2805-262-12.
- c. Allow engine to cool off longer after removing end item load.
- d. In extreme hot temperatures, the engine will run efficiently but at a reduced horse power rating. For each 10°F (12.2°C) above 60°F (15.5°C), a 1 percent loss of power should be expected.

2-14. **Operating at Different Altitudes.** The procedures for operating the engine are the same as under usual conditions. The engine will operate at altitudes of up to 5000 feet above sea level but at a reduced horse power rating. For every 1000 feet above sea level, a 3.5 percent power loss should be expected.

ARMY TM 9-2805-262-14
AIR FORCE TO 38G2-90-1
NAVY NAVFAC P-8-613-14E

2-15. Operation in Extreme Cold. The engine can be operated in temperatures as cold as -25°F (-32°C). The procedures for operating are the same as under usual conditions excepts for the following special precautions.

- a. Protect the engine from icing. Remove ice and snow from engine as often as possible.
- b. Allow engine sufficient warm-up time before apply end item load.
- c. Use appropriate grade oil per LO 9-2805-262-12.

CHAPTER 3

OPERATOR'S MAINTENANCE INSTRUCTIONS

	Page
OVERVIEW	3-1
Section I. Lubrication Instructions	3-1
Section II. Operator Troubleshooting Procedures	3-1

OVERVIEW

This chapter contains operator level maintenance instructions.

Section I. LUBRICATION INSTRUCTIONS

Paragraph	Page
3-1 General	3-1
3-2 Lubrication	3-1

3-1. **General.** This section contains operator lubrication instructions.

3-2. **Lubrication.** Refer to L0 9-2805-262-12 and perform operator level lubrication procedures. Operate the engine (para.2–9) for at least 5 minutes after lubrication. Stop the engine (para 2–10)and perform operator level After Operation Preventive Maintenance Checks and Services (PMCS).

Air Force personnel use applicable T.O. 35C2-3-1-426 work cards for lubrication instructions.

Section II. OPERATOR TROUBLESHOOTING PROCEDURES

Paragraph	Page
3-3 General	3-1
3-4 Operator Troubleshooting Procedures	3-1

3-3. **General.** This section contains troubleshooting procedures to determine the probable cause of observed equipment malfunctions. inspections are provided to isolate the faulty component and corrective actions are provided to eliminate the malfunction.

3-4. Operator Troubleshooting Procedures. Refer to the Symptom Index to locate the troubleshooting procedure for the observed malfunction.

- a. Table 3-1 lists the common malfunctions which you may find during operation of 6 HP Military Standard Gasoline Engine Models 4A032-1, -2, -3, -4 and its components. Perform the test/inspections in the order listed.
- b. This manual cannot list all malfunctions that may occur, nor all tests or inspections and corrective actions. If a malfunction is not corrected by listed corrective actions, notify your supervisor, and/or unit maintenance.

SYMPTOM INDEX

Symptom	Page
Engine will not start	3-2
Engine runs excessively hot	3-2
Engine starts but fails to keep running	3-3

Table 3-1. Operator Troubleshooting Procedures.

Malfunction	Test or Inspection	Corrective Action
-------------	--------------------	-------------------

1. ENGINE WILL NOT START

Step 1. Check end item fuel supply.

Replenish fuel supply if low.

Step 2. Check fuel shutoff valve

Turn valve counterclockwise to open.

Step 3. Check choke position.

Choke should be in closed position for starting.

Step 4. Check ignition switch models 4A032-1 (serial nos. G001001 through G004004), -2, -3, -4.

Set ignition switch to RUN position.

If engine still won't start, notify unit maintenance.

2. ENGINE RUNS HOT

Step 1. Check oil level.

Replenish oil if low.

Step 2. Check that cooling system ducts, covers, and deflectors are present and serviceable.

Notify unit maintenance if missing or damaged.

Table 3-1. Operator Troubleshooting Procedures (cont).

Malfunction	Test or Inspection	Corrective Action
-------------	--------------------	-------------------

3. ENGINE STARTS BUT FAILS TO KEEP RUNNING.

NOTE

If engine is warm, the choke may not need to be closed completely.

Step 1. Check choke position.

If engine is cold, close choke.

If engine is warm, close choke halfway.

Step 2. Check fuel shutoff valve.

Turn valve counterclockwise to open.

If engine still fails to keep running, notify unit maintenance.

CHAPTER 4

UNIT MAINTENANCE

	Page
OVERVIEW	4-1
Section I. Repair Parts; Special Tools; Measurement, Diagnostic Equipment (TMDE); and Support Equipment	4-1
Section II. Service Upon Receipt	4-2
Section III. Unit Preventive Maintenance Checks and Services (PMCS)	4-2
Section IV. Unit Troubleshooting	4-3
Section V. Unit Maintenance Procedures	4-8
Section VI. Preparation for Shipment or Storage	4-106

OVERVIEW

This chapter contains those maintenance instructions that unit level maintenance is authorized to perform.

Section I. REPAIR PARTS; SPECIAL TOOLS; TEST, MEASUREMENT, DIAGNOSTIC EQUIPMENT (TMDE); AND SUPPORT EQUIPMENT

Paragraph		Page
4-1	Common Tools and Test Equipment.....	4-1
4-2	Special Tools, TMDE, and Support Equipment	4-1
4-3	Repair Parts	4-1

4-1. Common Tools and Equipment. For authorized common tools and equipment, refer to the Modified Table of Organization and Equipment (MTOE) applicable to your unit.

4-2. Special Tools, TMDE, and Support Equipment. For a listing of special tools, TMDE, and support equipment authorized for use on this equipment, refer to the Repair Parts and Special Tools List, TM 9-2805-262-24P, and the Maintenance Allocation Chart (MAC), appendix B, of this manual.

4-3. Repair Parts. Repair parts are listed and illustrated in the Repair Parts and Special Tools List for 6hp Military Standard Engine, TM 9-2805-262-24P.

Section II. SERVICE UPON RECEIPT

Paragraph	Page
4-4 Inspection	4-2
4-5 Lubrication	4-2
4-6 Testing	4-2

4-4. Inspection.

- a. Inspect the equipment for damage incurred during shipment. If the equipment has been damaged, report the damage on SF Form 364, Report of Discrepancy (ROD).
- b. Check the equipment against the packing slip to see the shipment incomplete. Report all discrepancies in accordance with the instructions of DA PAM 738-750.
- c. Check to see whether the equipment has been modified.

4-5. **Lubrication.** Refer to LO 9-2805-262-12 and perform unit level and operator level lubrication on engine.

4-6. **Testing.** Perform unit level PMCS, and operator Before (B) PMCS before starting engine. Start engine, para. 2-9, and run for at least 15 minutes. Observe the engine during operation. If any malfunctions arise, troubleshoot using table 4-2.

Section III. UNIT PREVENTIVE MAINTENANCE CHECKS AND SERVICES (PMCS)

Paragraph	Page
4-7 General	4-2
4-8 PMCS Procedures	4-2

4-7. **General.** Unit level maintenance PMCS are done to ensure that the engine is in top operating condition. A comprehensive PMCS program reduces equipment downtime and increases the operational readiness of the engine.

4-8. **PMCS Procedures.** Unit level PMCS is contained in table 4-1. The numbers in the Item No. column show the order in which the check or service should be done. These numbers should be used when recording deficiencies and shortcomings on DA Form 2404, Equipment Inspection and Maintenance Worksheet. The (dot Ž) in the Interval column indicates when a check or service should be done, as follows:

Table 4-1. Unit Preventive Maintenance Checks and Services (PMCS).

Item No.	Interval		H	Item Inspected	Procedure
	D	S			
1		●		Spark Plug	Clean, inspect, and regap (para. 4-28).
2		●		High Tension Cables	Inspect and test (para. 4-27).
3		●		Breaker Points	Inspect, adjust breaker points (para. 4-49).
4		●		Fuel Filter	Service fuel filter (para. 4-13).
5		●		Crankcase Ventilation System	Inspect breather box and breather tube (para. 4-40).
6	●			Air Cleaner	Service air cleaner daily in extreme heat or dusty or sandy conditions (para. 4-14).
7			5	Crankcase Oil	Drain and refill crankcase oil and service oil filter in extreme heat or dusty or sandy conditions. Refer to LO 9-2805-262-12.

Section IV. UNIT TROUBLESHOOTING

Paragraph	Page
4-9 General	4-3
4-10 Unit Troubleshooting Procedures	4-3

4-9. **General.** This section contains troubleshooting procedures to determine the probable cause of observed equipment malfunctions. Tests or inspections are provided to isolate the faulty component and corrective actions are provided to eliminate the malfunction.

4-10. **Unit Troubleshooting Procedures.** Refer to the symptom index to locate the troubleshooting procedure for the observed malfunction. The table lists the common malfunctions that may occur during the operation or maintenance of the engine. Perform the tests of inspections, and the recommended corrective action in the order listed in the troubleshooting table. If the malfunction is corrected by a specific correction action, do not continue with the remaining steps, if any, of the troubleshooting procedure. If the malfunction is not corrected by the listed corrective actions notify your supervisor, and/or direct support (DS) maintenance.

SYMPTOM INDEX

Symptom	Page
Engine fails to start	4-4
Engine starts but fails to keep running	4-6
Engine misses or runs erratically.	4-6
Engine surges or overspeeds	4-7
Engine over heats	4-7

Table 4-2. Unit Troubleshooting Procedures.

Malfunction		
	Test or Inspection	
		Corrective Action

1. ENGINE FAILS TO START.

Step 1. Remove air clean element and start engine (para. 2-9).

If engine starts, service air cleaner (para. 4-14).

Step 2. Check ignition switch models 4A032-1 (serial nos. G001001 through G004004), -2, -3, -4.

Replace ignition switch if defective (para.4-45).

Step 3. Inspect spark plugs.

Clean, regap, or replace spark plugs as necessary (para. 4-28).

NOTE

This procedure may be performed with either a digital or analog multimeter.

Step 4. Check spark plug cables.

Replace a defective spark plug cable (para. 4-27).

Step 5. Check breaker point gap.

Adjust breaker point gap as needed (para. 4-49).

Step 6. Check ignition timing.

Adjust ignition timing as needed (para. 4-50).

Table 4-2. Unit Troubleshooting Procedures (cont).

Malfunction

Test or Inspection

Corrective Action

Step 7. Test condenser as follows:

NOTE

The procedures to test the condenser are the same for both condensers. Perform the test on one condenser then repeat the procedures for second condenser.

- a. Turn engine over so that breaker points (para. 4-49, figure 4-50) are in open position.
- b. Connect positive lead of multimeter to condenser terminal lead.
- c. Set multimeter to highest resistance setting and zero meter.
- d. Connect second lead of multimeter to ground while observing meter.

If meter shows a deflection, then goes to infinity, then go to next step.

If no deflection occurs or does not go to infinity after deflection, relate condenser (para. 4-46).

If meter doesn't return to infinity, remove connection between points and condenser and retest. If deflection occurs, replace points (para. 4-49).

Step 8. Check breaker points,

NOTE

This engine is equipped with two sets of points, perform the test on both sets.

- a. Turn engine over so that breaker points (para. 4-49, figure 4-50) close.
- b. Connect one lead of multimeter to condenser terminal.
- c. Set multimeter to lowest resistance setting and zero meter.
- d. Connect second lead of multimeter to ground while observing meter.

If meter shows full scale deflection, go to next step. If no deflection or partial deflection occurs, then replace breaker point (para. 4-49).

Step 9. Check fuel flow out of fuel filter.

Service fuel filter if fuel does not flow (para. 4-13).

Table 4-2. Unit Troubleshooting Procedures (cont).

Malfunction

Text or inspection

Corrective Action

Step 10. Check carburetor adjustments.

Adjust carburetor as needed (para. 4-25).

If engine still will not start, refer to DS maintenance.

2. ENGINE STARTS BUT FAILS TO KEEP RUNNING.

Step 1. Remove air cleaner element and start engine (para. 2-9).

If engine stays running, service air cleaner (para. 4-1 4).

Step 2. Check fuel flow out of fuel filter assembly.

If fuel flow is not present or steady, service fuel filter assembly (para. 4- 13).

Step 3. Check screen at fuel inlet of carburetor.

Clean as needed.

Step 4. Check carburetor adjustments.

Adjust carburetor as needed (para. 4-25).

Step 5. Check fuel pump pressure (para. 4-37).

Replace fuel pump if pressure is inadequate (para. 4-37).

If engine fails to keep running, refer to DS maintenance.

3. ENGINE MISSES OR RUNS ERRATICALLY.

Step 1. Check spark plugs.

Clean, regap, or replace worn spark plugs (para. 4-28).

Step 2. Check spark plug cables.

Replace a defective spark plug cable (para. 4-27).

Step 3. Check breaker point gap.

Adjust or replace worn breaker points (para. 4-49).

Step 4. Check fuel flow out of fuel filter assembly.

If fuel flow is not present or steady, service fuel filter assembly (para. 4- 13).

Table 4-2. Unit Troubleshooting Procedures (cont).

Malfunction	Test or Inspection	Corrective Action
		Step 5. Remove air cleaner element and start engine (para. 2-9).
		If engine runs properly, service air cleaner (para. 4-14).
		If engine continues to miss or run erratically, refer to DS maintenance.
		4. ENGINE SURGES OR OVERSPEED.
		Step 1. Check Governor.
		Adjust governor (para. 4-21).
		Step 2. Check carburetor adjustments.
		Adjust carburetor as needed (para 4-25).
		If engine still surges or overspeeds, refer to DS maintenance.
		5. ENGINE OVERHEATS.
		Step 1. Check oil level.
		Add oil as needed.
		Step 2. Check cooling system.
		Repair or replace a damaged or missing cooling system component (para. 4-33 through 4-36) .
		If engine continues to overheat, refer to DS maintenance.

Section V. UNIT MAINTENANCE PROCEDURES

Paragraph		Page
4-11	General	4-9
4-12	Painting	4-9
4-13	Fuel Filter Assembly	4-10
4-14	Air Cleaner Assembly	4-12
4-15	Clamps and Ducts	4-16
4-16	Air Cleaner Element	4-18
4-17	Service Indicator	4-20
4-18	Governor Control Assembly	4-22
4-19	Oil Tube	4-27
4-20	Throttle Control Assembly	4-28
4-21	Governor	4-30
4-22	Governor Assembly	4-32
4-23	Fuel Line	4-34
4-24	Air Intake Elbow	4-36
4-25	Carburetor	4-38
4-26	Carburetor Adapter	4-44
4-27	High Tension Cables	4-46
4-28	Spark Plugs	4-48
4-29	Preheater	4-50
4-30	Exhaust Manifold	4-52
4-31	Relief Valve	4-54
4-32	Rocker Box Cover	4-56
4-33	Winterization Shroud	4-58
4-34	Cylinder Head Cover, Internal Cover and Baffles	4-60
4-35	Oil Pan Cover	4-64
4-36	Top Cover	4-66
4-37	Fuel Pump	4-68
4-38	Intake Manifold and Intake Manifold Hoses and Clamps	4-70
4-39	Intake Manifold Adapters,	4-72
4-40	Breather Box Cover and Breather Tube	4-74
4-41	Oil Filter	4-76
4-42	Oil Filter Head	4-80
4-43	Starter Rope Pulley	4-82
4-44	Breaker Point Cover	4-84
4-45	Ignition Switch	4-88
4-46	Condenser(Breaker Point Ignition)	4-92
4-47	Coil Cover	4-94
4-48	Noise Suppression Filters (Breaker Point Ignition)	4-98
4-49	Breaker Points(Breaker Point Ignition)	4-100
4-50	Ignition Timing(Breaker Point Ignition)	4-104

4-11. **General.** This section contains unit level maintenance procedures as authorized by the MAC in Appendix B of this manual. Refer to Appendix E, Torque Limits, when performing maintenance on engine. All maintenance procedures require only one person to perform,

4-12. **Painting.** Refer to TM 43-0139 for painting procedures.

4-13. Fuel Filter Assembly.

This task covers: a. Disassembly b. Cleaning c. Reassembly

INITIAL SETUP

<i>Tools</i>	<i>Materials/Parts</i>
General Mechanic's Tool Kit (Item 1, Appendix B)	Rags, Wiping (Item 7, Appendix D) Solvent, Drycleaning (Item 8, Appendix D)

WARNING

Do not smoke or use an open flame in the vicinity of gasoline vapors.

a. Disassembly. (figure 4-1)

- (1) Close fuel shutoff valve (1).
- (2) Loosen thumbscrew (2) and swing bail (3) out of way.
- (3) Remove bowl (4), gasket (5), and filter screen (6) from fuel filter head (7).

b. Cleaning.

WARNING

Drycleaning solvent PD-680 used to clean parts is potentially dangerous to personnel and property. Avoid repeated and prolonged skin contact. Do not use near open flame or excessive heat. Flash point of solvent is 100°F-138°F (38°C-60°C).

- (1) Clean fuel filter head (7) using drycleaning solvent.
- (2) Clean fuel filter screen (6) using drycleaning solvent and replace if torn or otherwise damaged.

c. Reassembly. (figure 40-1).

- (1) Install gasket (5) and filter screen (6) in fuel filter head (7), replace gasket if damaged.
- (2) Position bowl (4) on fuel filter head (7), swing bail (3) down and secure with thumbscrew (2).

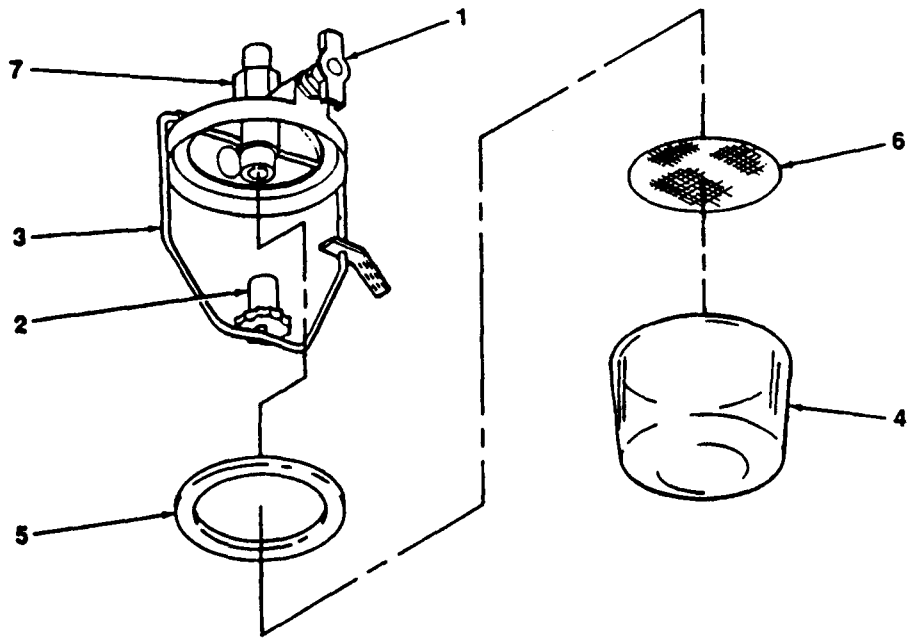

4868-007

Figure 4-1. Fuel Filter, Disassembly and Reassembly.

4-14. **Air Cleaner Assembly.**

This task covers: a. Service b. Removal c. Installation

INITIAL SETUP

Tools

Materials/Parts

General Mechanic's Tool Kit (Item 1, Appendix B)

Detergent (Item 1, Appendix D)

a. Service. (figure 4-2).

- (1) Loosen two retaining bolts (1) and lift upper housing (2), out of way.
- (2) Remove element (3) from lower housing (4).
- (3) Clean element (3) in detergent and water, and dry thoroughly.
- (4) Clean upper (2) and lower (4) housings.
- (5) Install element (3) in lower housing (4).
- (6) Install upper housing (2) and secure with two retaining bolts (1).
- (7) Depress reset button (5) on service indicator(6).

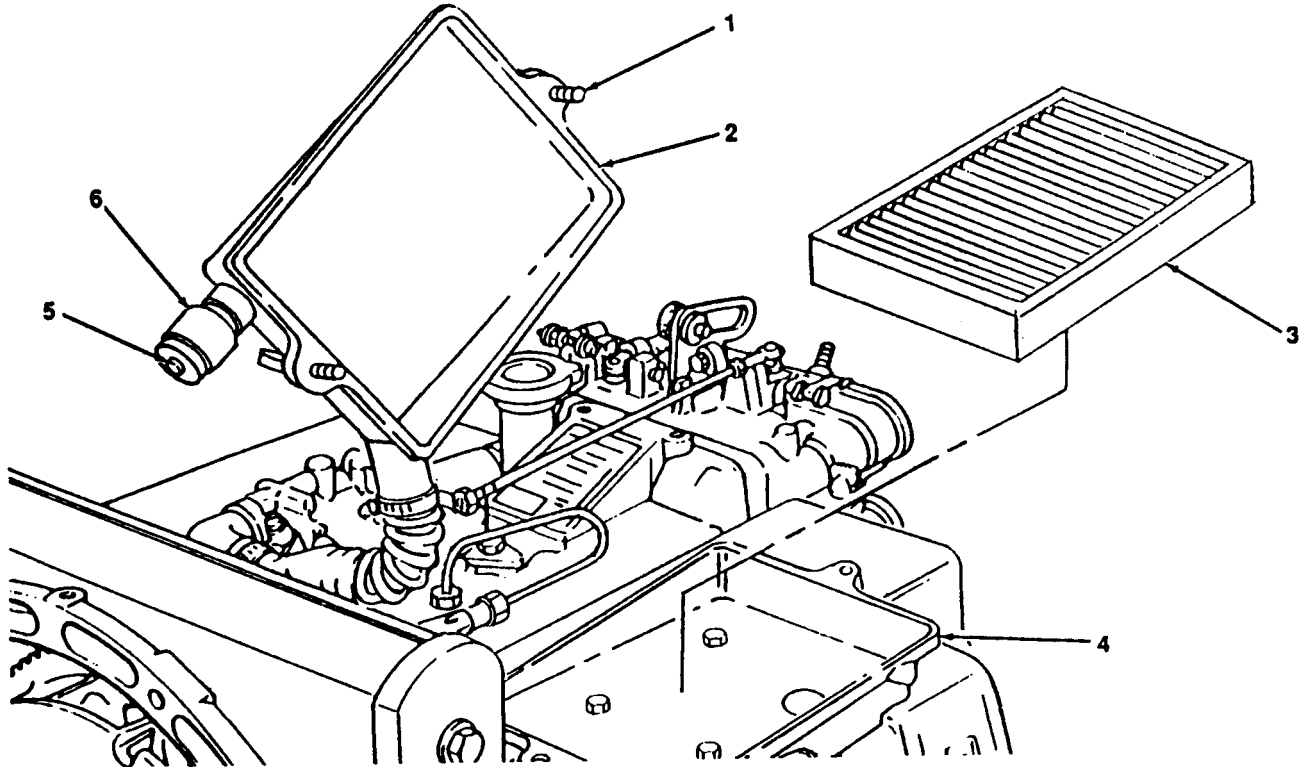

4868-008

Figure 4-2. Air Cleaner, Service.

4-14. **Air Cleaner Assembly (cont).**

b. Removal. (figure 4-3)

- (1) Loosen clamp (1) and disconnect duct (2) from upper housing (3).
- (2) Loosen clamp (4) and disconnect duct (5) from lower housing (6).
- (3) Loosen two retaining bolts (7) and remove upper housing (3).
- (4) Remove element (8) from lower housing (6).
- (5) Remove three screws (9) and washers (10) and remove lower housing (6) and bracket (11).

NOTE

Perform step 6 only if bracket or lower housing are being replaced.

- (6) Remove bolt (12), washer (13), lockwasher (14) and nut (15) and remove bracket(11) from lower housing (6).

c. Installation. (figure 4-3)

- (1) Install bracket (11) and secure with bolt (12), washer (13), lockwasher (14), and nut (15).
- (2) Install lower housing (6) and secure with three screws (9) and washers (10).
- (3) Install element (8) in lower housing (6).
- (4) Install upper housing (3) and secure with two retaining bolts (7).
- (5) Install duct (5) on lower housing (6) and tighten clamp (4).
- (6) Install duct (2) on upper housing (3) and tighten clamp (1).

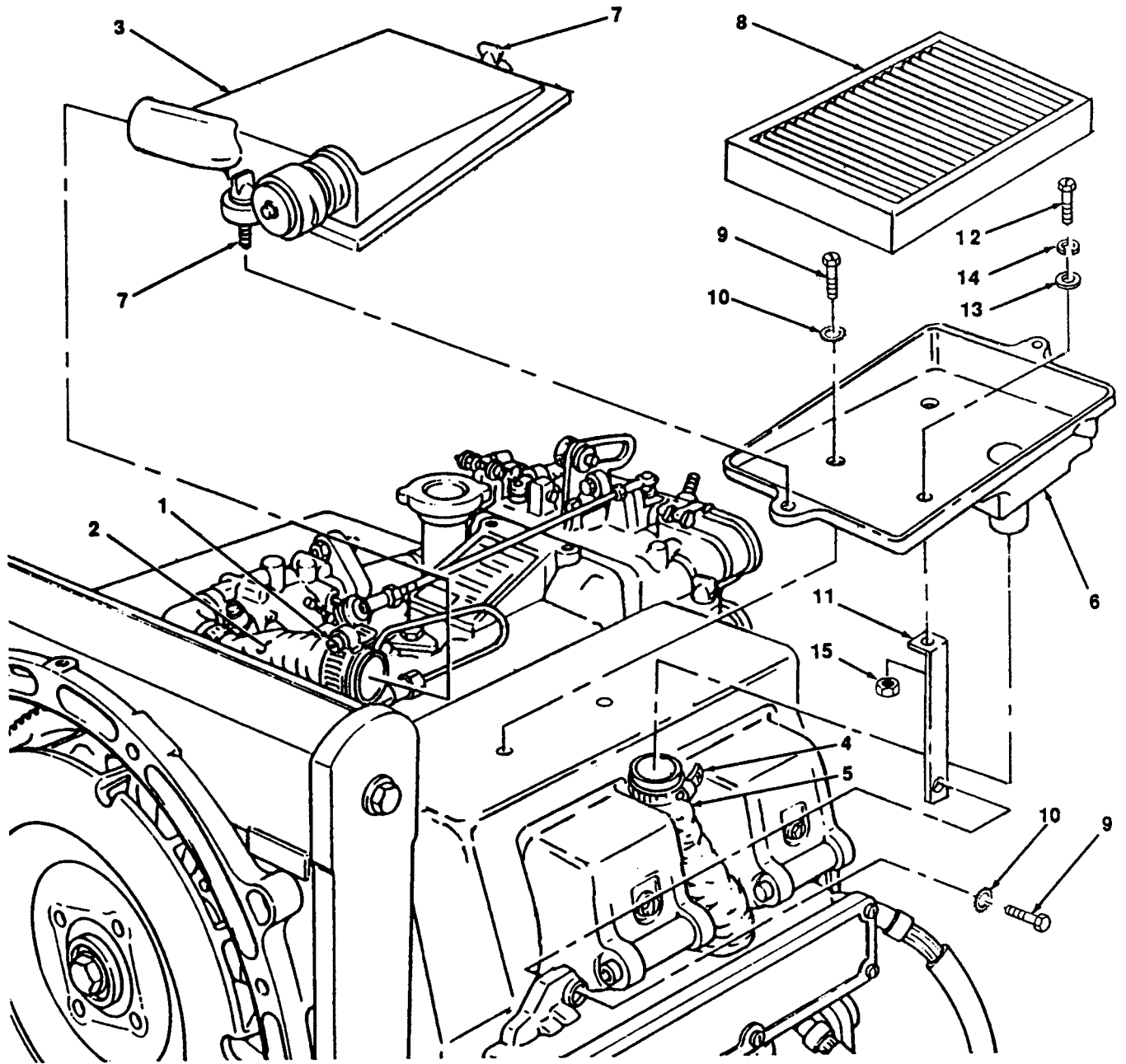

4868-009

Figure 4-3. Air Cleaner, Removal and Installation.

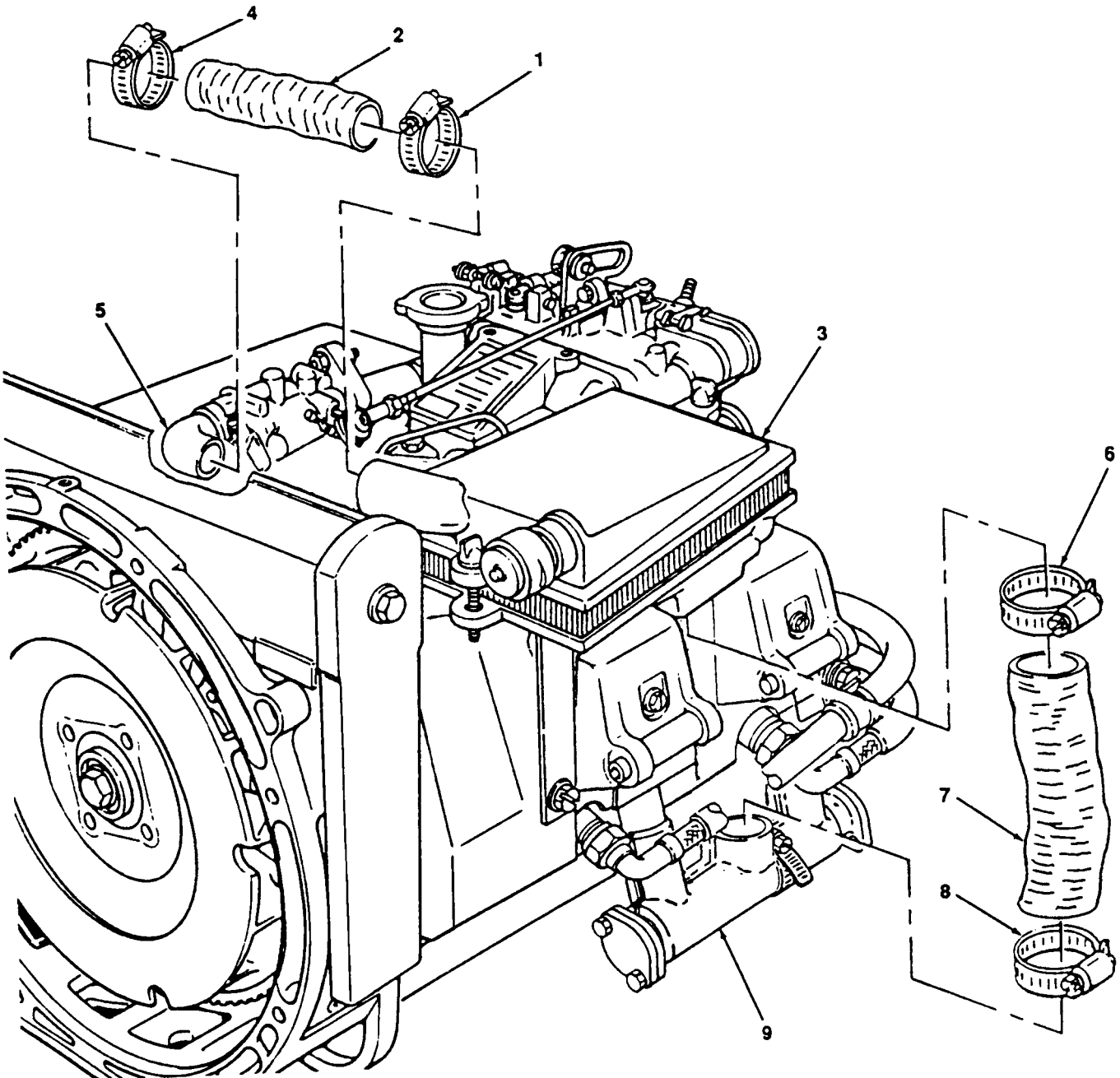

4868-010

Figure 4-4. Clamps and Ducts, Removal and Installation.

4-16. **Air Cleaner Element.**

This task covers: a. Removal

b. Installation

INITIAL SETUP

Tools

General Mechanic's Tool Kit (Item 1, Appendix B)

a. Removal. (figure 4-5)

- (1) Loosen two retaining bolts (1) and lift off upper housing (2).
- (2) Remove element (3) from lower housing (4).

b. Installation. (figure 4-5)

- (1) Install element (3) in lower housing (4).
- (2) Install upper housing (2) and secure with two retaining bolts (1).

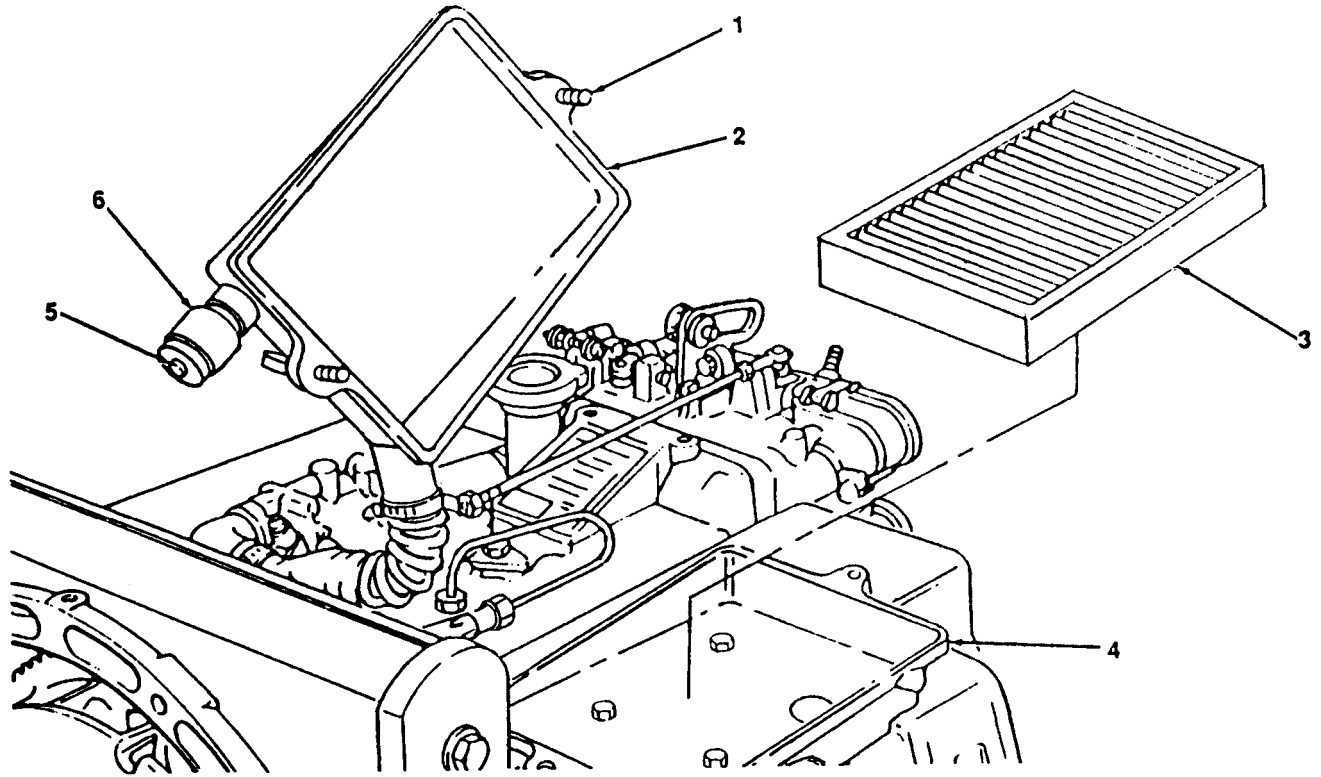

4868-011

Figure 4-5. Air Cleaner Element, Removal and Installation.

4-17. **Service Indicator.**

This task covers: a. Remove b. Inspect c. Install

INITIAL SETUP

Tools

General Mechanic's Tool Kit (Item 1, Appendix B)

a. Remove. (figure 4-6)

Unscrew service indicator (1) from air cleaner (2).

b. Inspect. (figure 4-6)

Inspect service indicator and replace if cracked or otherwise damaged.

c. Install. (figure 4-6)

Install service indicator (1) in air cleaner (2).

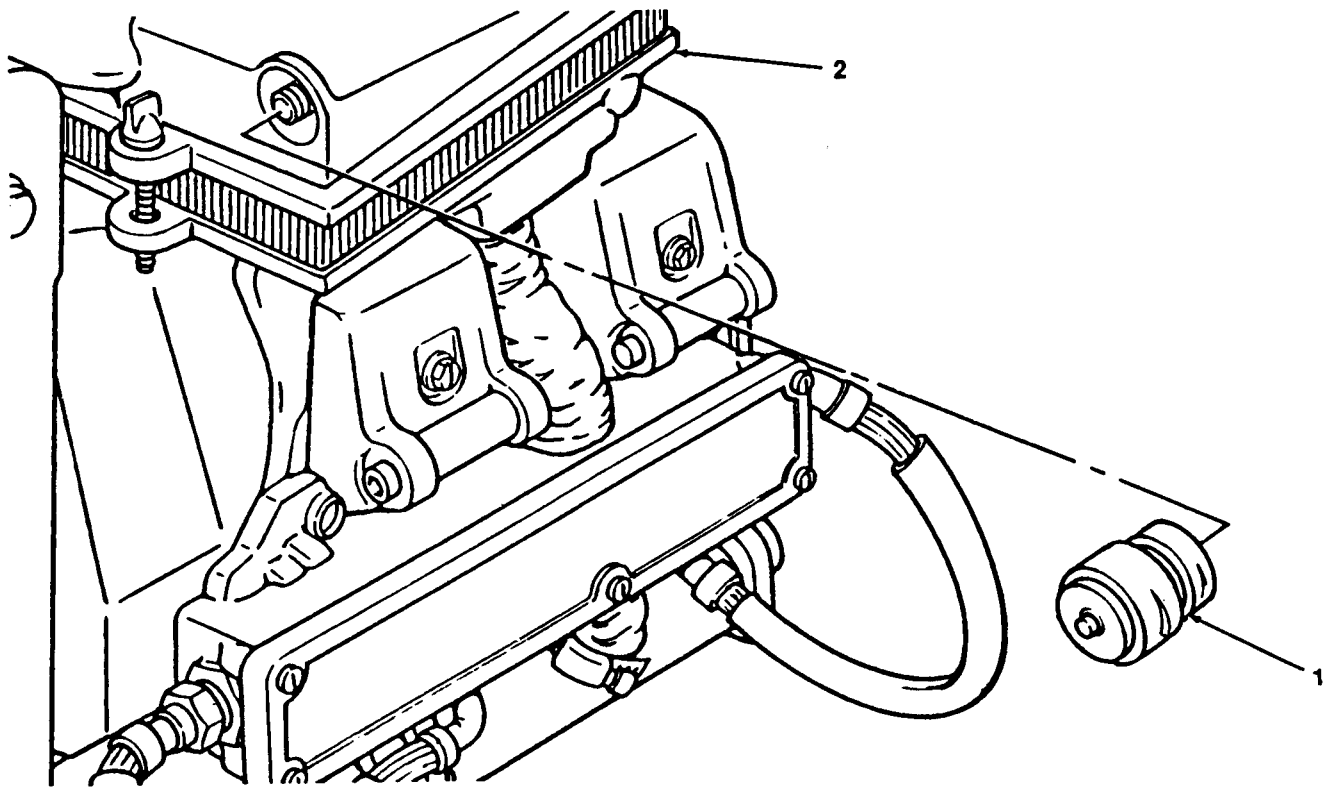

4868-012

Figure 4-6. Service Indicator, Replacement.

4-18. **Governor Control Rod.**

This task covers:

a. Adjustment	c. Repair
b. Removal	d. Installation

INITIAL SETUP

<i>Tools</i>	<i>Materials/Parts</i>
General Mechanic's Tool Kit (Item 1, Appendix B)	Rags, Wiping (Item 7, Appendix D) Solvent, Drycleaning (Item 8, Appendix D) Lockwasher (P/N 13218E0518-38)

- a. Adjustment. (figure 4-7)
- (1) Remove nut (1) and lockwasher (2) securing governor control rod (3) to throttle lever (4).
 - (2) Loosen lock nut (5).
 - (3) Hold throttle lever (4) against stop.
 - (4) Turn ball joint (6) clockwise or counterclockwise until shaft (7) on ball joint (6) aligns with mounting hole in throttle lever (4) and tighten lock nut (5).
 - (5) Install shaft (7) in throttle lever (4) and secure with nut(1) and washer (2).

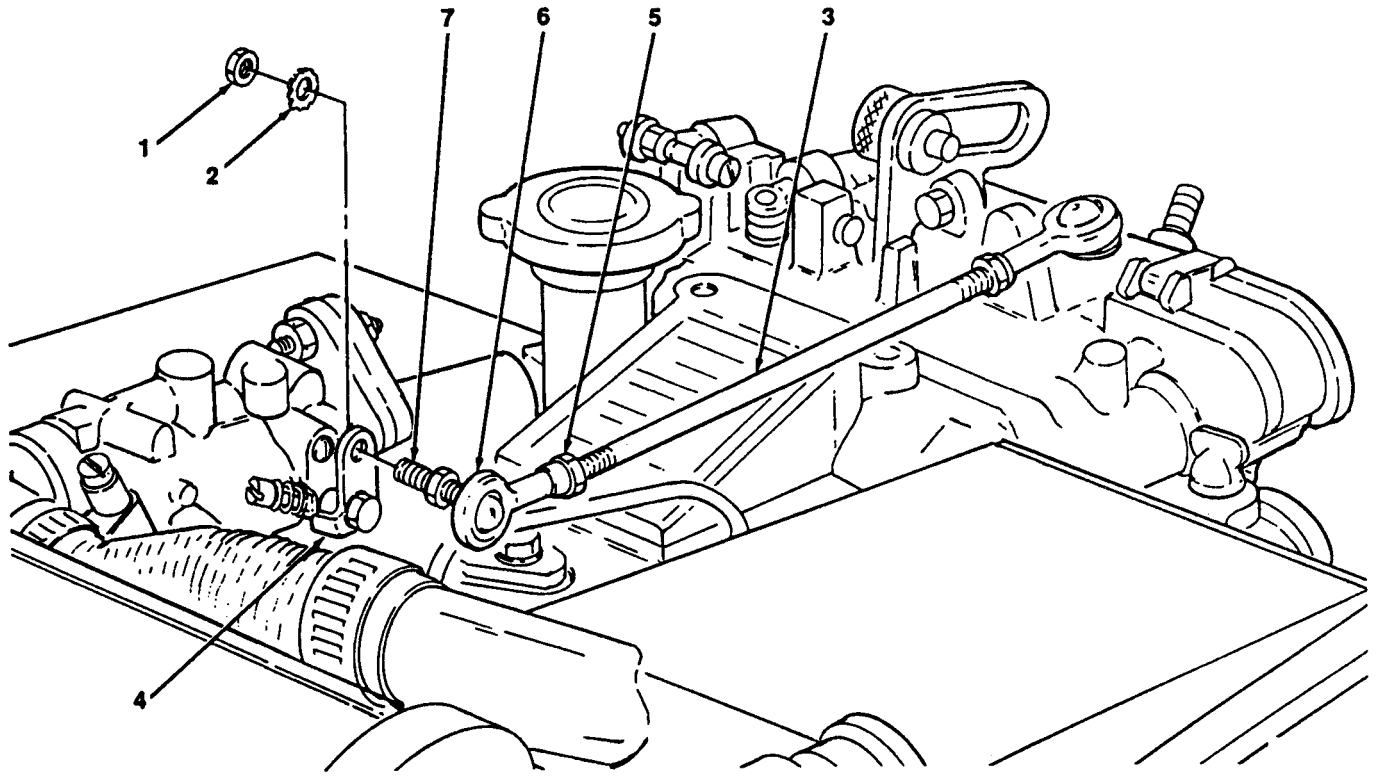

4868-037

Figure 4-7. Governor Control Rod, Adjustment.

4-18. Governor Control Rod (cont).

b. *Removal* (figure 4-8).

(1) Remove nut (1) and washer (2) and disconnect governor control rod (3) from throttle lever (4).

(2) Loosen ball joint nut (5) and remove governor control rod (3).

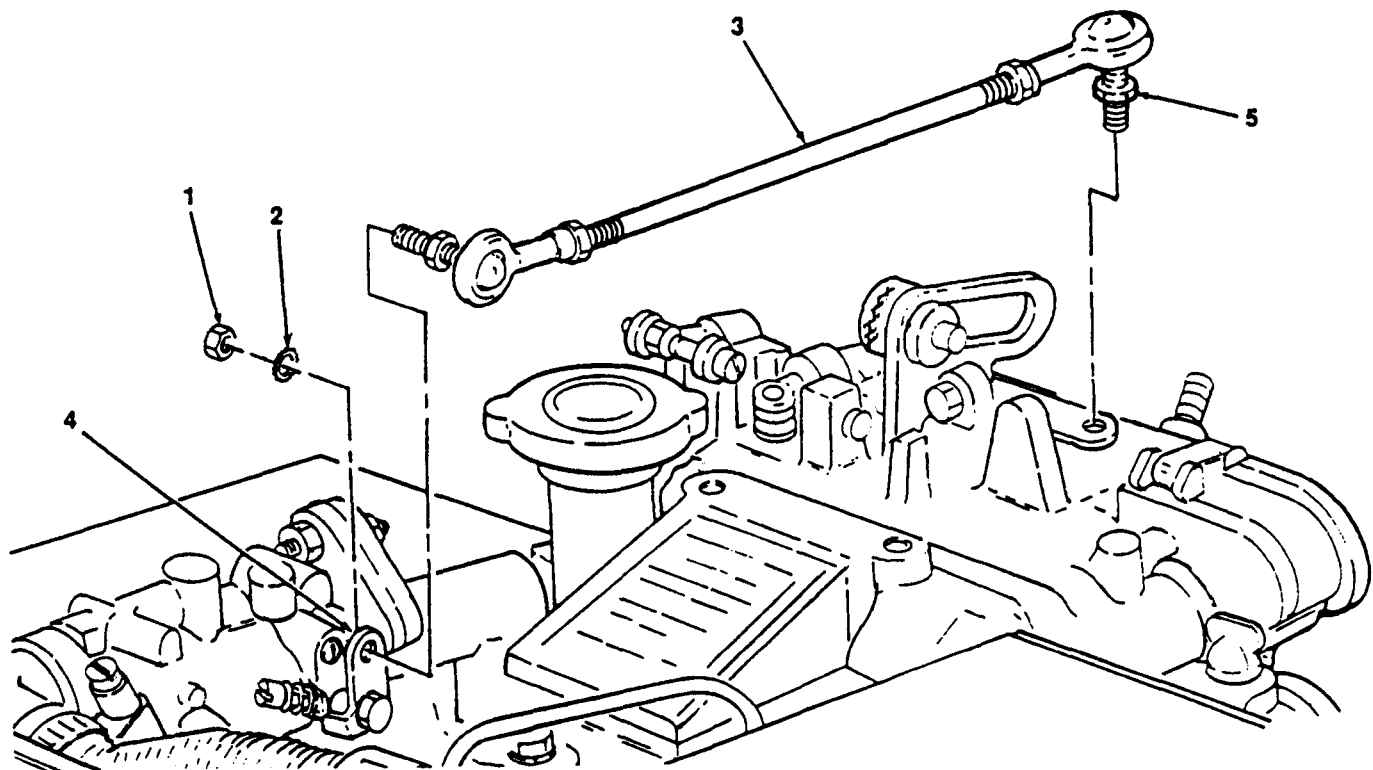

4868-038

Figure 4-8. Governor Control Rod, Removal.

c. *Repair.* (figure 4-9).

WARNING

Drycleaning solvent PD-680 used to clean parts is potentially dangerous to personnel and property. Avoid repeated and prolonged skin contact. Do not use near open flame or excessive heat. Flash point of solvent is 100°F-138°F (38°C-60°C).

- (1) Clean governor control rod with drycleaning solvent, and dry thoroughly.
- (2) Loosen lock nuts (1) and unscrew ball joints (2) from control rod (3).
- (3) Inspect all components and replace any component that is worn, bent, or otherwise damaged.
- (4) Install lock nuts (1) and ball joints (2)

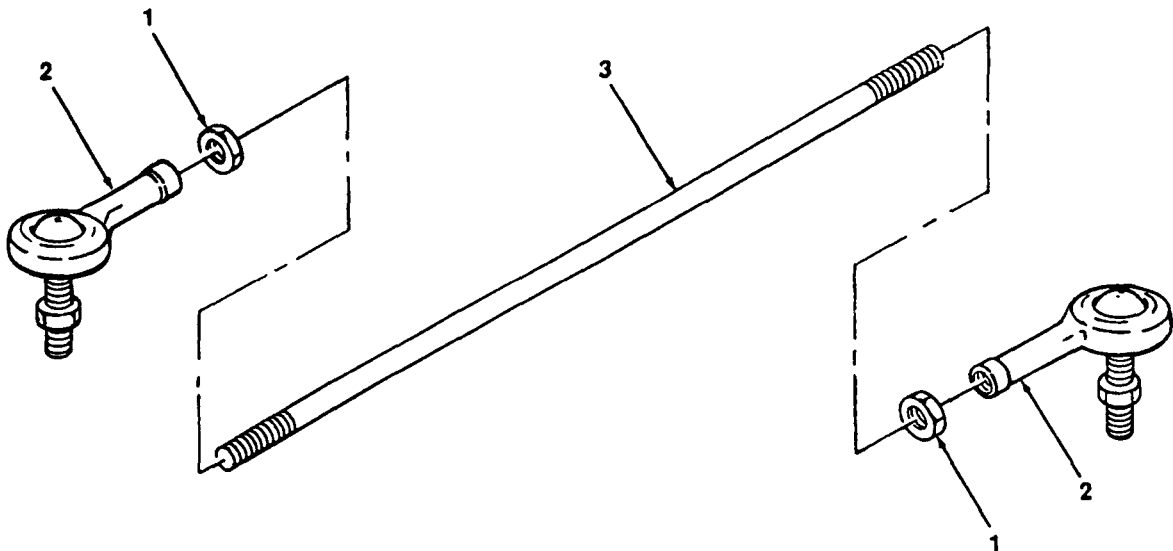

4868-039

Figure 4-9. Governor Control Rod, Repair.

4-18. **Governor Control Rod (cont).**

d. *Installation.* (figure 4-10)

- (1) Install governor control rod (3) in governor control arm (6) and tighten ball joint nut (5) and locknut (7).
- (2) Push throttle lever (4) to idle.
- (3) Adjust length of governor control rod (1) until ball joint shaft (8) aligns with mounting hole in throttle lever (4).
- (4) Install governor control rod (3) and secure with nut (1) and lockwasher (2).
- (5) Tighten lock nut (9).

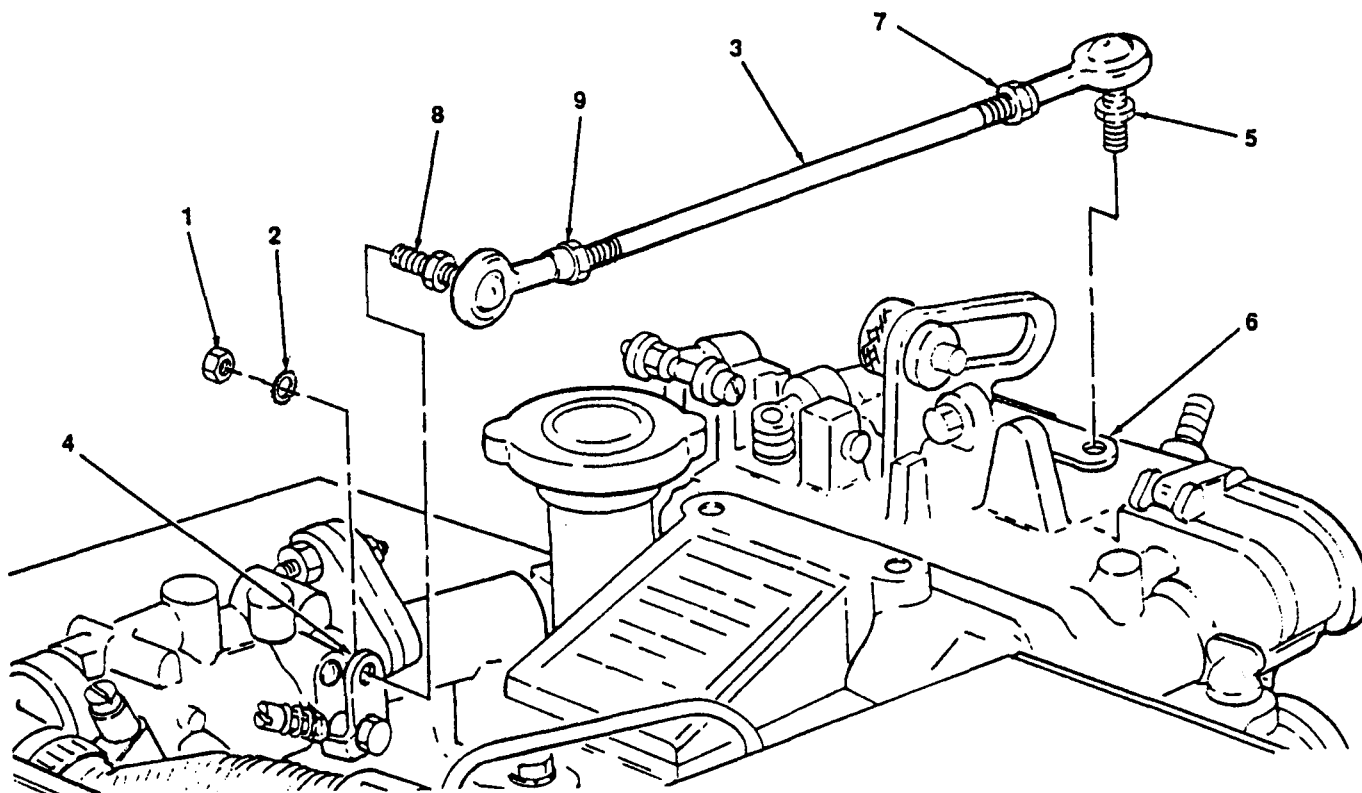

4868-040

Figure 4-10. Governor Control Rod, Installation.

4-19. Oil Tube.

This task covers: Replacement

INITIAL SETUP

Tools

General Mechanic's Tool Kit (Item 1, Appendix B)

Replacement. (figure 4-11)

- (1) Loosen two nuts (1) and remove oil tube (2).
- (2) Inspect oil tube (2) and replace if threads on nuts (1) are stripped or oil tube shows other signs of damage.
- (3) Install oil tube (2) and finger tighten both nuts (1), then fully tighten both.

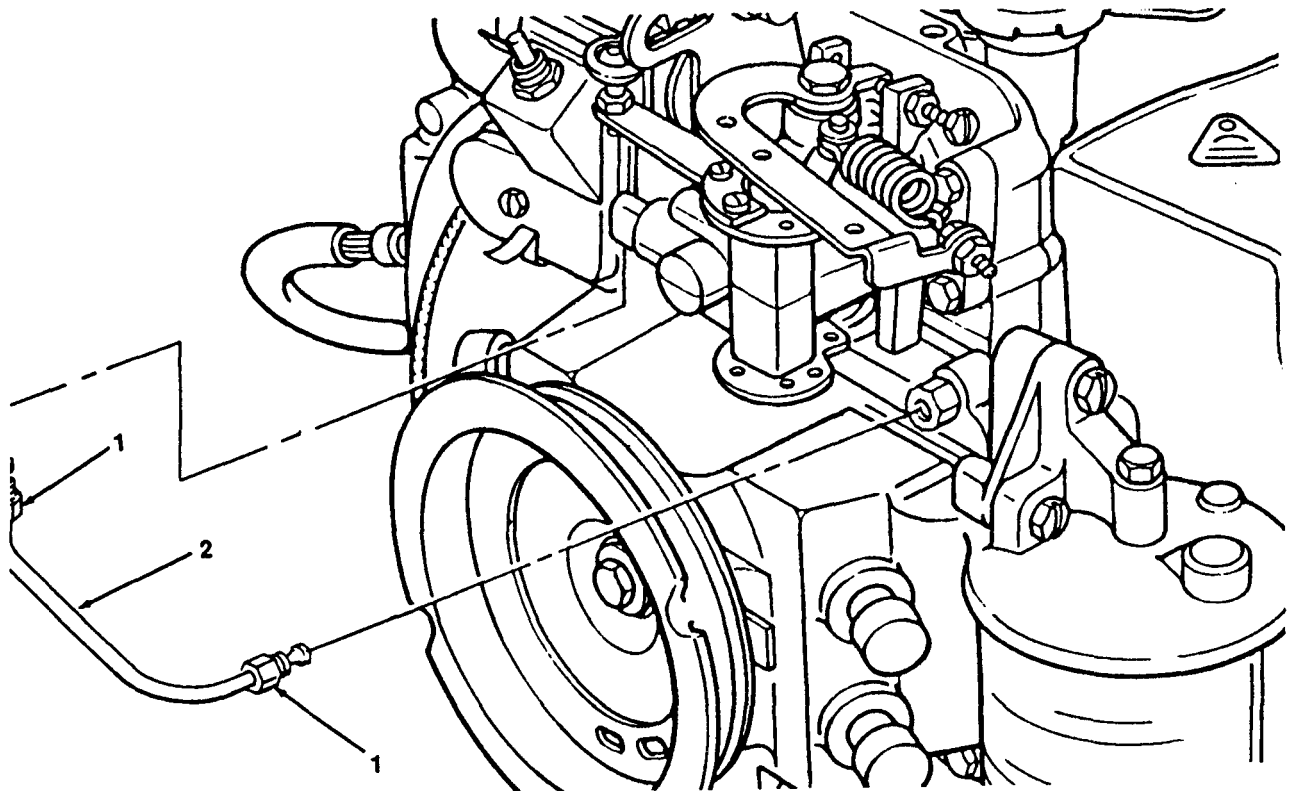

4868-013

Figure 4-11. Oil Tube, Replacement.

4-20. **Throttle Control Assembly.**

This task covers: Replacement

INITIAL SETUP

Tools

General Mechanic's Tool Kit (Item 1, Appendix B)

Replacement. (figure 4-12)

- (1) Remove two screws (1) and washers (2) and remove throttle control assembly (3).
- (2) Install throttle control assembly (3) and secure with two screws (1) and washers (2).

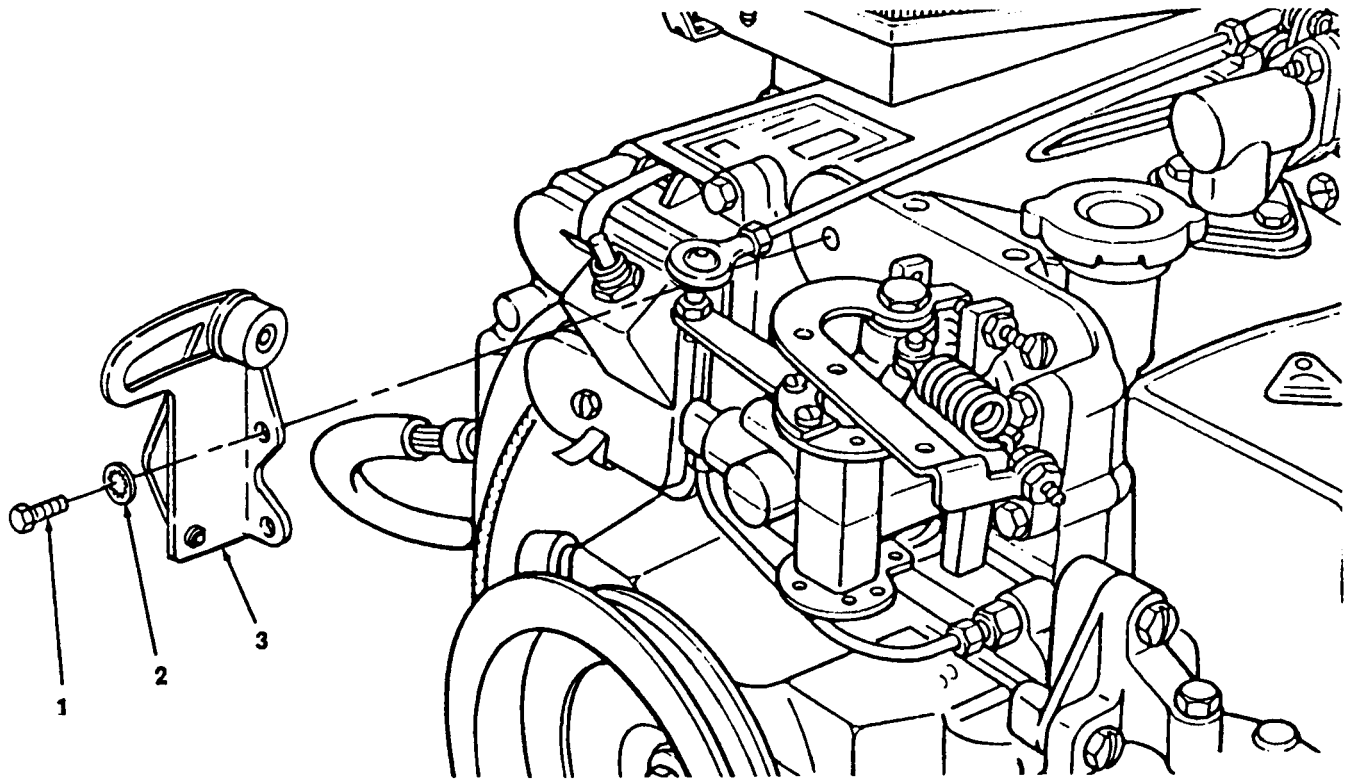

4866-014

Figure 4-12. Throttle Control Assembly, Replacement.

4-21. **Governor.**

This task covers: Adjustment

INITIAL SETUP

<i>Tools</i>	<i>Equipment Condition</i>
General Mechanic's Tool Kit (Item 1, Appendix B) Test Set, Tachometer and Dwell (NSN 4910-00-788-8549) (Item 2, Appendix B)	Governor control rod adjusted (para. 4-18).

Adjustment. (figure 4-13)

- (1) Start engine (para. 2-9), and apply end item load.
- (2) Loosen speed adjusting screw lock nut (1).
- (3) Turn adjusting screw (2) clockwise to increase, or counterclockwise to decrease engine speed, and set speed to 3600 r.p.m.
- (4) Tighten locknut (1) while holding screw (2) to keep it from turning and recheck engine speed.
- (5) Loosen inner droop adjusting screw locknut (3).
- (6) Turn outer locknut (4) counterclockwise until engine surges. Then turn locknut (4) clockwise until surging stops.
- (7) Recheck engine speed, and perform steps 2 through 6 if engine speed is incorrect.
- (8) Tighten inner droop adjusting screw locknut (3).
- (9) Remove end item load and stop engine (para. 2-10).

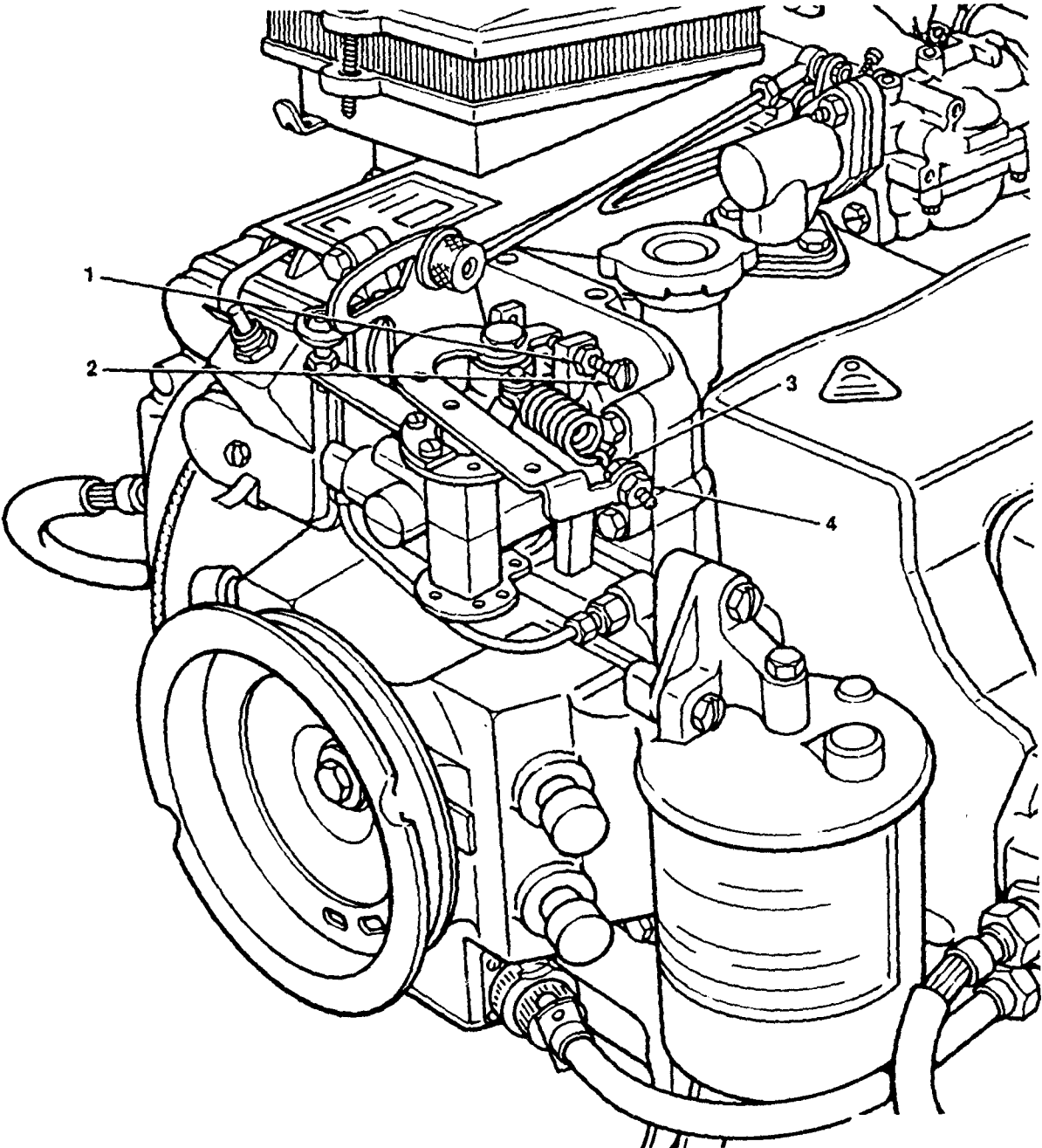

4868-015

Figure 4-13. Governor, Adjustment.

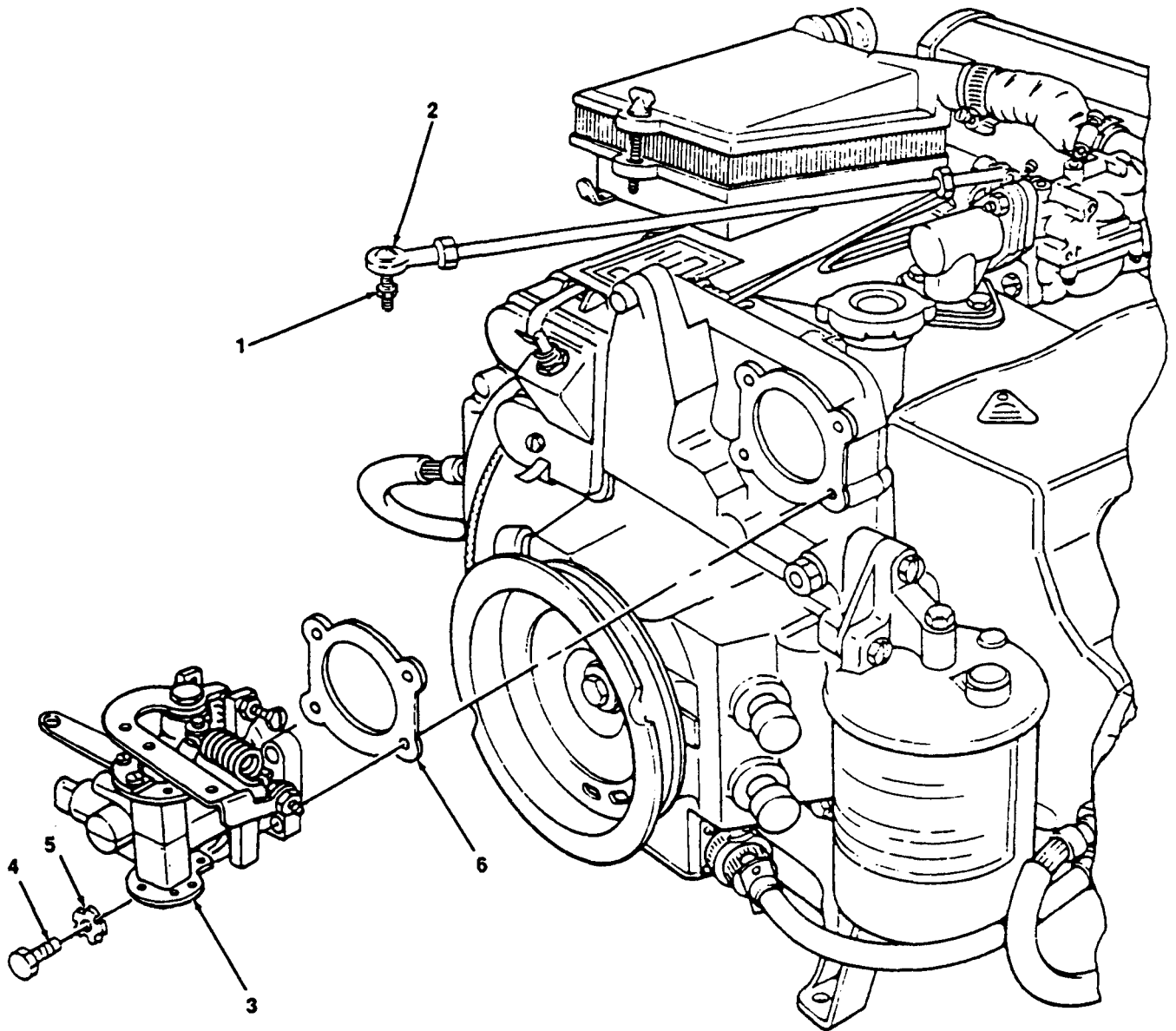

4868-016

Figure 4-14. Governor, Removal and Installation.

4-23. Fuel Line.

This task covers: Replacement

INITIAL SETUP

Tools

General Mechanic's Tool Kit (Item 1, Appendix B)

WARNING

Do not smoke or use an open flame in the vicinity of gasoline vapors.

Replacement. (figure 4-15)

- (1) Loosen fitting nuts (1) and (2) and remove fuel line (3).
- (2) Inspect threads on fitting nuts (1) and (2) and replace fuel line (3) if threads are stripped, or fuel line is otherwise damaged.
- (3) Install fuel line (3) and tighten fitting nuts (1) and (2).

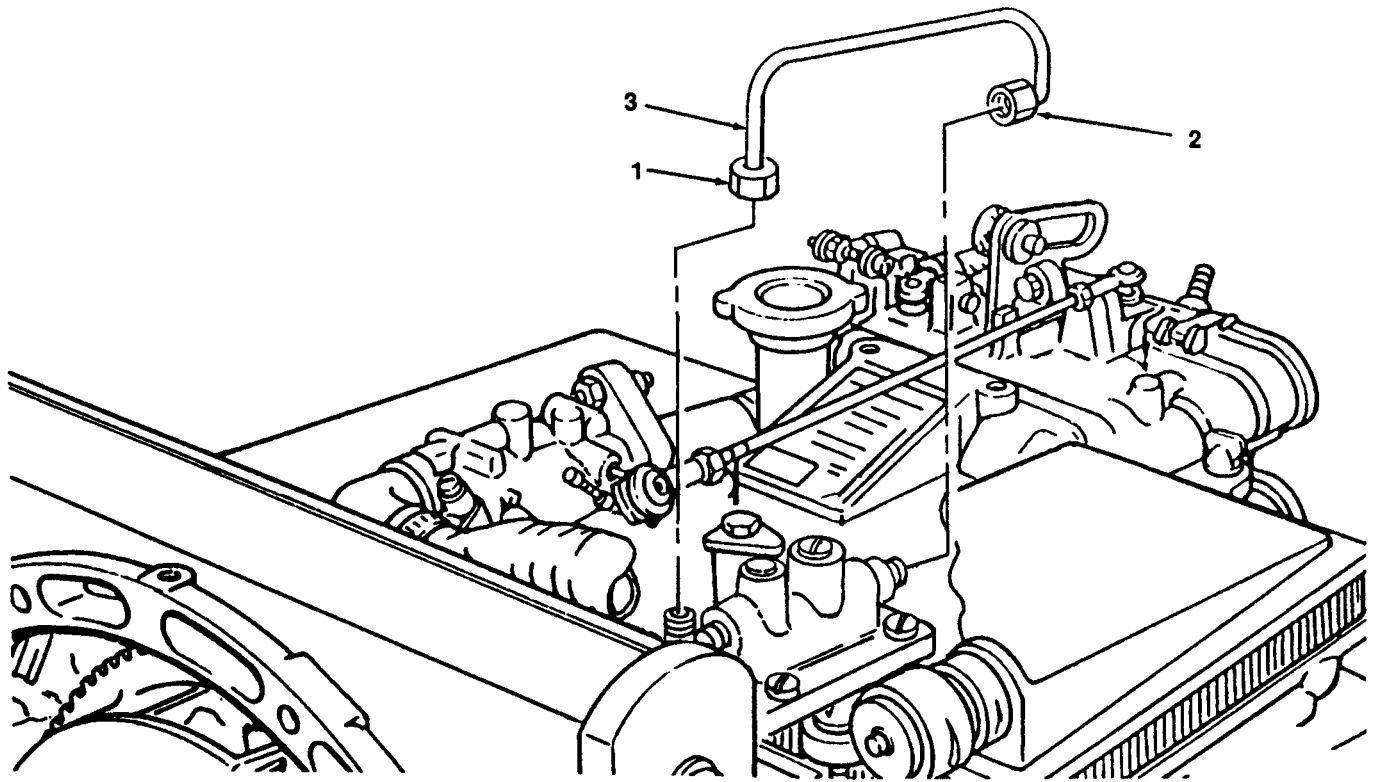

Figure 4-15. Fuel Line, Replacement.

4868-017

4-24. **Air Intake Elbow.**

This task covers: a. Removal b. Installation

INITIAL SETUP

Tools

Materials/Parts

General Mechanic's Tool Kit (Item 1, Appendix B)

Gasket, Carburetor Mounting (P/N 9786E26-2)

a. Removal. (figure 4-16)

- (1) Loosen clamp (1) and remove duct (2) from air intake elbow (3).
- (2) Remove two screws (4) and washers (5), loosen clamp (6) and remove air intake elbow (3) and gasket (7) from carburetor (8), and breather tube connector (9).
- (3) Inspect air intake elbow (3) and replace if cracked or otherwise damaged.

b. Installation. (figure 4-16)

- (1) Make sure gasket surfaces are clean and free of old gasket.
- (2) Loosen clamp (6) and install air intake elbow (3) on breather tube connector(9).
- (3) Install gasket (7) and secure air intake elbow (3) to carburetor(8) with two screws (4) and washers(5).
- (4) Install duct (2) on air intake elbow(3) and tighten clamp(I).

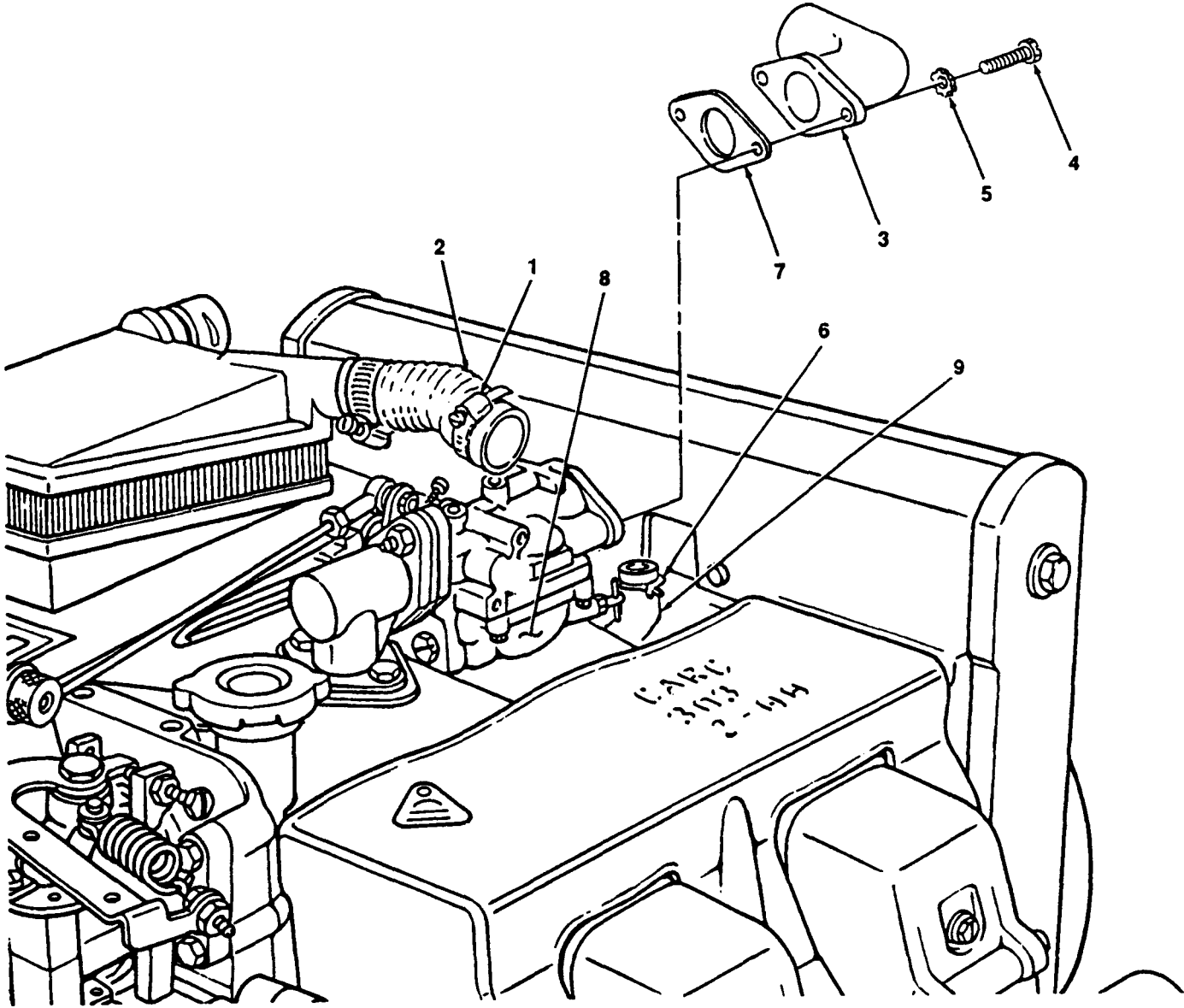

4868-018

Figure 4-16. Air Intake Elbow, Removal and installation.

4-25. **Carburetor.**

This task covers:	a. Adjustment	c. Inspection
	b. Removal	d. Installation

INITIAL SETUP

Tools

General Mechanic's Tool Kit (Item 1, Appendix B)
 Test Set, Tachometer and Dwell
 (NSN 4910-00-788-8549) (Item 2, Appendix B)

Equipment Condition

Air intake elbow removed for removal or carburetor
 (para. 4-24).

Materials/Parts

Rags, Wiping (Item 7, Appendix D)
 Solvent, Drycleaning (Item 8, Appendix D)
 Gasket, Carburetor Mounting (P/N 9786E26-2)

a. Adjustment. (figure 4-17)

- (1) Turn main adjustment needle (1) and idle adjustment screw (2) fully clockwise.
- (2) turn main adjustment needle (1) 3/4 of a turn counterclockwise.
- (3) Turn idle adjustment needle (2) 1/2 turn counterclockwise.
- (4) Start engine (para. 2-9), and allow engine to warm-up.
- (5) Apply a load, and adjust main adjustment needle(1) until a smooth idle is achieved.
- (6) Set idle speed adjustment (3) to idle position.
- (7) Adjust idle speed of engine by adjusting idle speed screw(2) until an idle speed of 200-900 r.p.m. is obtained.
- (8) Stop engine (para. 2-10).

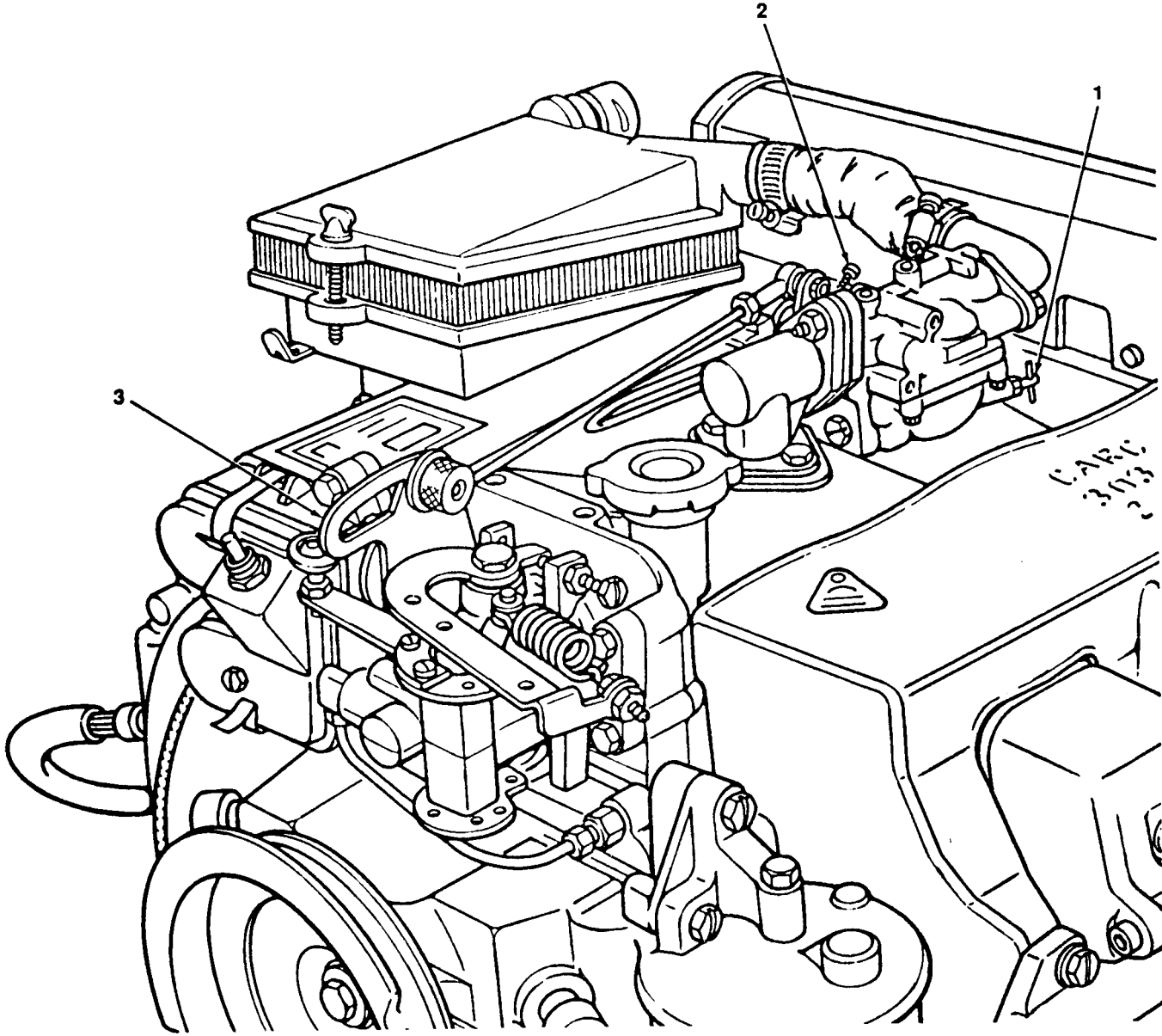

Figure 4-17. Carburetor, Adjustment.

4-25. Carburetor (cont).

WARNING

Do not smoke or use an open flame in the vicinity of gasoline vapors.

b. Removal (figure 4-18)

- (1) Remove nut (1) and washer (2) and disconnect governor control rod (3) from carburetor (4).
- (2) Loosen coupling nut (5) and disconnect fuel line (6).
- (3) Remove two nuts (7) and lockwashers (8) and remove carburetor(4) and gasket(9).

c. Inspection. (figure 4-1 8)

WARNING

Drycleaning solvent PD-680 used to clean parts is potentially dangerous to personnel and property. Avoid repeated and prolonged skin contact. Do not use near open flame or excessive heat. Flash point of solvent is 100°F-138°F (38°C- 60°C).

- (1) Clean carburetor with drycleaning solvent, and dry thoroughly.
- (2) Inspect carburetor body for cracks, and stripped threads, fuel inlet screen, and replace carburetor as needed.

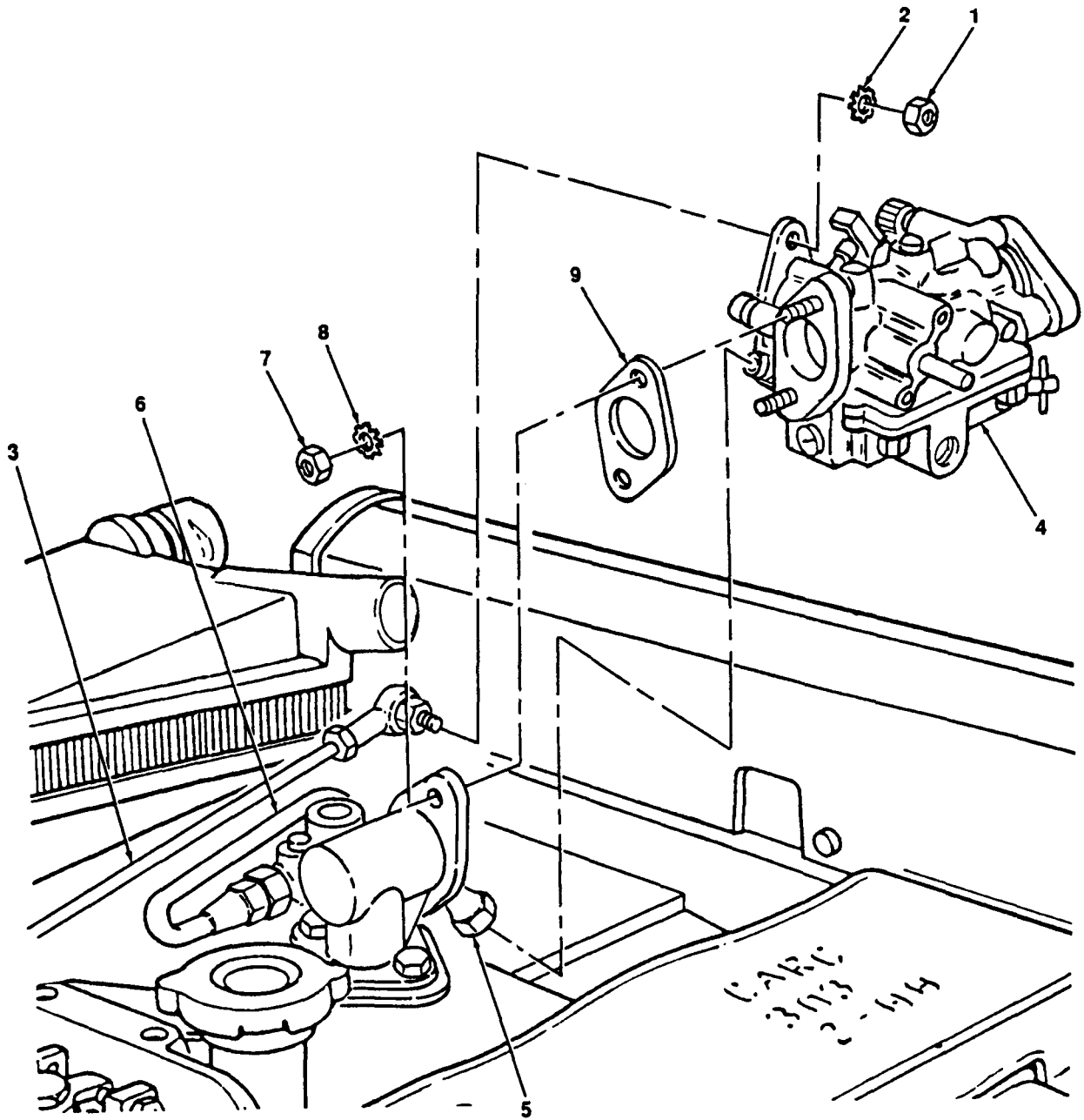

4868-034

Figure 4-18. Carburetor, Removal and Inspection.

4-25. **Carburetor (cont).**

d. *Installation.* (figure 4-19)

- (1) Ensure gasket mating surfaces are clean, and free of old gasket material.
- (2) Install carburetor (4) and new gasket (9) and secure with two nuts (7) and lockwashers (8).
- (3) Install fuel line (6) and tighten coupling nut (5).
- (4) Install governor control rod (3) and secure with nut (1) and washer (2).
- (5) Adjust carburetor (para. 4-25.a.).

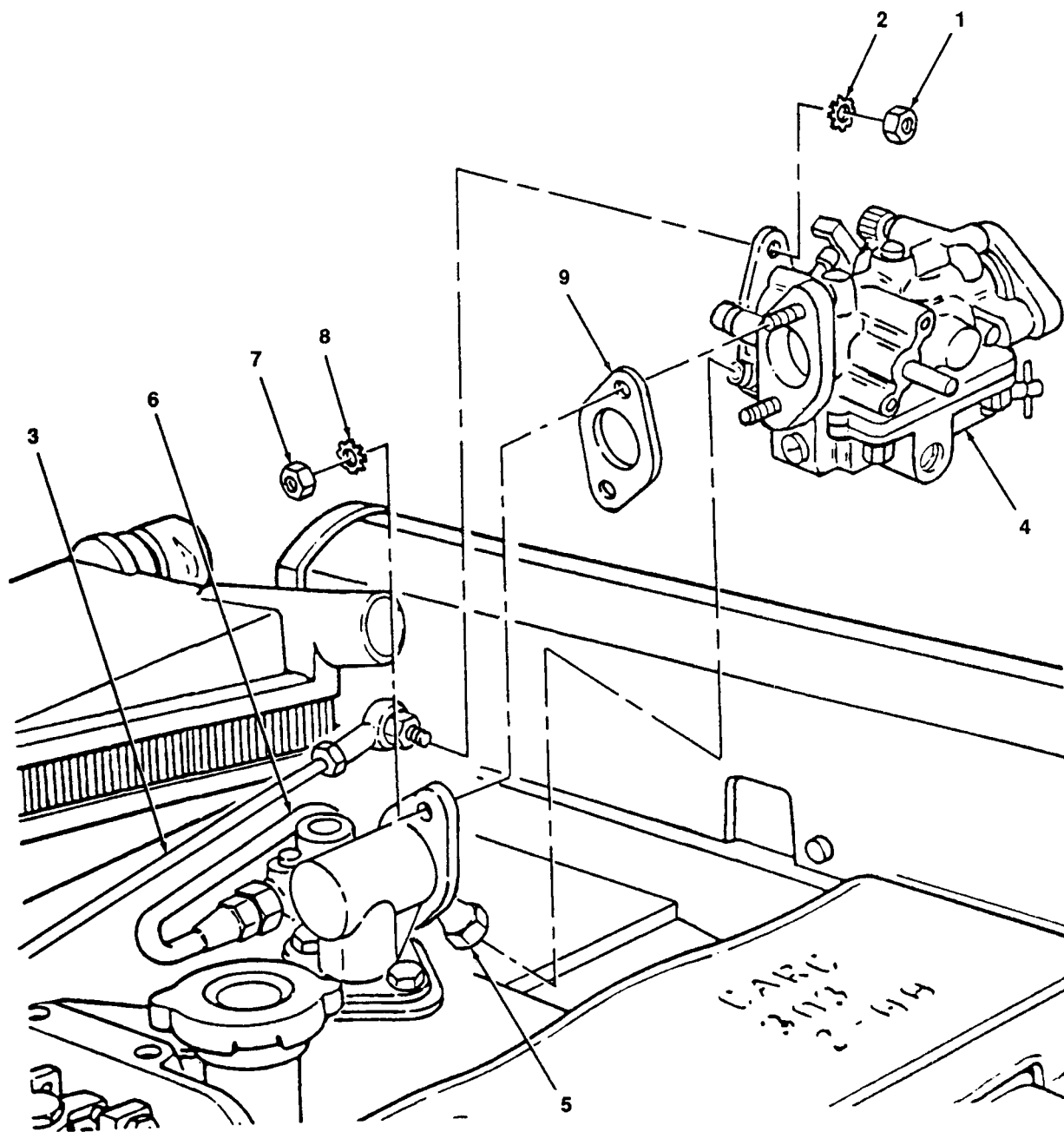

4868-035

Figure 4-19. Carburetor, Installation.

4-26. **Carburetor Adapter.**

This task covers: Replacement

INITIAL SETUP

Tools

Equipment Condition

General Mechanic's Tool Kit (Item 1, Appendix B)

Carburetor removed (para. 4-25).

Materials/Parts

Rags, Wiping (Item 7, Appendix D)

Solvent, Drycleaning (Item 8, Appendix D)

Gasket, Adapter to Intake Manifold
(P/N 13214E8193)

Replacement. (figure 4-20)

- (1) Remove two screws (1) and washers (2) and remove carburetor adapter (3) and gasket (4).

WARNING

Drycleaning solvent PD-680 used to clean parts is potentially dangerous to personnel and property. Avoid repeated and prolonged skin contact. Do not use near open flame or excessive heat. Flash point of solvent is 100°F-138°F(38°C-60°C).

- (2) Clean carburetor adapter (3) in drycleaning solvent and dry thoroughly.
- (3) Inspect carburetor adapter (3) for cracks and replace if cracked or otherwise damaged.
- (4) Ensure gasket surfaces are clean and old gasket material is removed.
- (5) Install carburetor adapter (3) and new gasket (4) and secure with two screws (1) and washers (2).

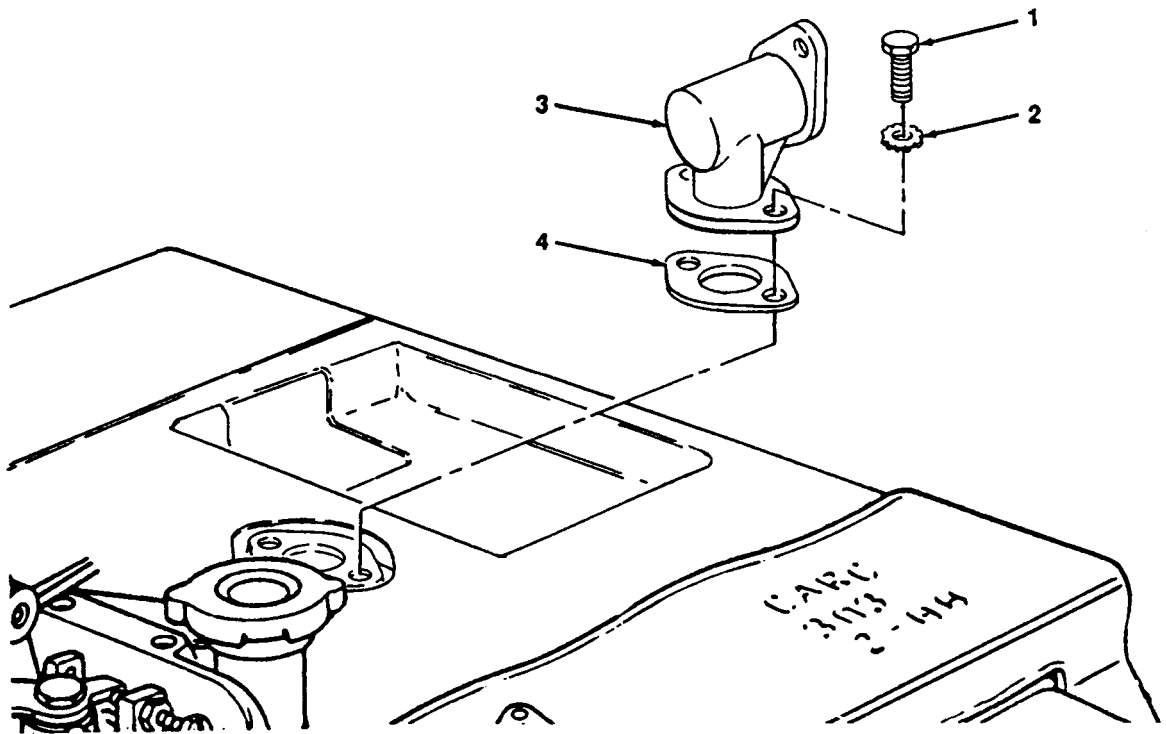

4868-036

Figure 4-20. Carburetor Adapter, Replacement.

4-27. High Tension Cables.

This task covers: a. Removal b. Inspection/Test c. Installation

INITIAL SETUP

Tools

General Mechanic's Tool Kit (Item 1, Appendix B)
Multimeter (NSN 6625-01-139-2512) (Item 2, Appendix B)

a. Removal (figure 4-21)

NOTE

Tag high tension cables before removing from engine.

When removing high tension cables on engines with breakerless ignition system, remove high tension cable from ignition control unit.

- (1) Loosen connector nut (1) and remove high tension cable (2) from spark plug (3).
- (2) Remove screw (4) and washer (5) and remove loop clamp (6) from high tension cable (2)
- (3) Loosen connector nut (7) and remove high tension cable (2) from coil cover (8).
- (4) Repeat steps 1 through 3 as necessary for remaining high tension cables.

b. Inspection/Test.

- (1) Inspect high tension cable (2) and replace cable if braided shield is frayed, spring end is distorted or damaged, or rubber end is ripped or otherwise damaged.
- (2) Perform continuity test between spring ends of high tension cable, replace cable if continuity is not present.
- (3) Perform continuity test between metal ends of high tension cable, replace if continuity is not present.
- (4) Perform continuity test between metal end and spring end of high tension cable, and replace if continuity is present.

c. Installation. (figure 4-21)

NOTE

When installing high tension cables on engines equipped with breakerless ignition system, connect high tension cable to ignition control unit.

- (1) Install high tension cable (2) as tagged, on coil cover (8) and tighten connector nut (7).
- (2) Install loop clamp (6) on high tension cable (2) and secure with screw (4) and washer (5).
- (3) Install high tension cable (2) on spark plug (3) and tighten connector nut (1).
- (4) Repeat steps 1 through 3 as necessary for remaining high tension cables.

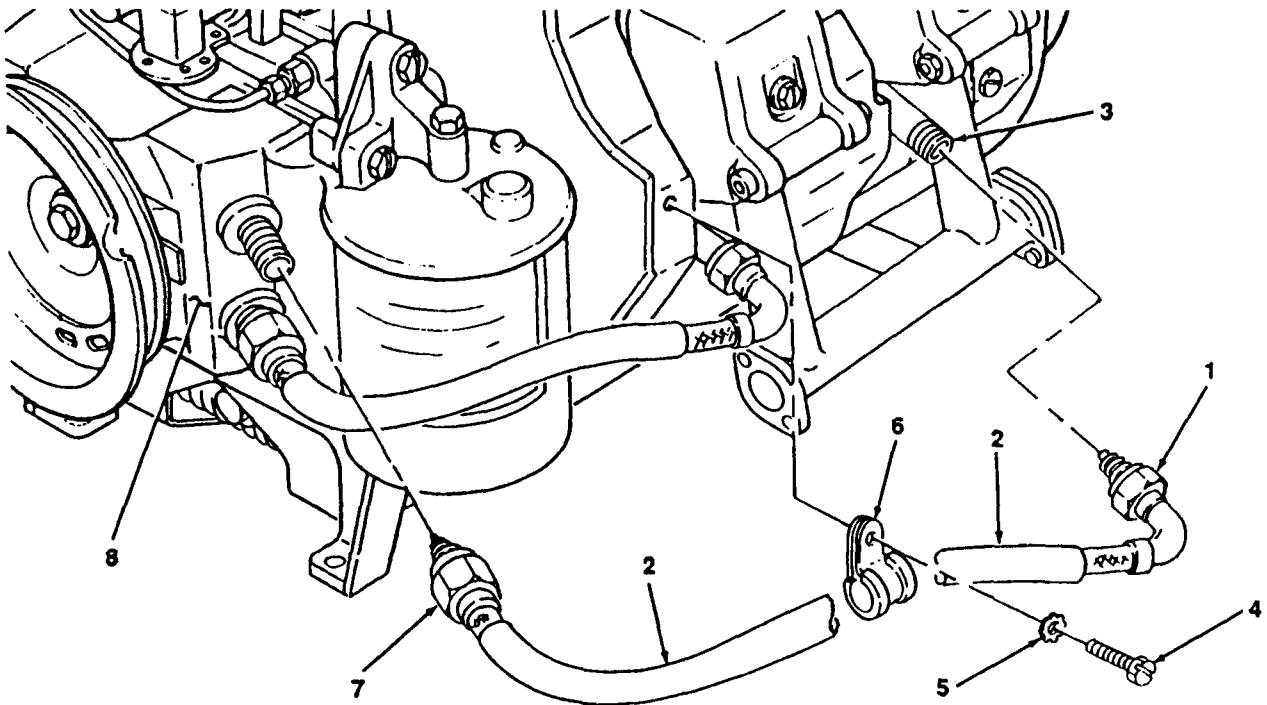

4868-020

Figure 4-21. High Tension Cables, Removal and Installation.

4-28. Spark Plugs.

This task covers: a. Removal b. Inspection/Test c. Installation

INITIAL SETUP

Tools

General Mechanic's Tool Kit (Item 1, Appendix B)
Wrench, Torque (NSN 5120-00-640-6364)
(Item 5, Appendix B)

Materials/Parts

Rags, Wiping (Item 7, Appendix D)
Solvent, Drycleaning (Item 8, Appendix D)

NOTE

The following procedures are the same for all spark plugs.

a. Removal. (figure 4-22).

- (1) Loosen connector nut (1) and tag and remove high tension cable (2) from spark plug (3).
- (2) Remove spark plug (3).

b. Inspection/Test. (figure 4-22).

WARNING

Drycleaning solvent PD-680 used to clean parts is potentially dangerous to personnel and property. Avoid repeated and prolonged skin contact. Do not use near open flame or excessive heat. Flash point of solvent is 100°F-138°F (38°C-60°C).

- (1) Clean spark plug (3) in drycleaning solvent, and dry thoroughly.
- (2) Inspect spark plug for stripped threads, burnt electrode, broken or cracked ceramic insulator, and replace a damaged spark plug.
- (3) Regap spark plug (3) to 0.028 to 0.033 in. (0.071 to 0.084 cm).

c. Installation. (figure 4-22)

- (1) Install spark plug (3) and torque to 23-25ftlb(49115-53580 gr cm).
- (2) Install high tension cable (2) and tighten connector nut (1).

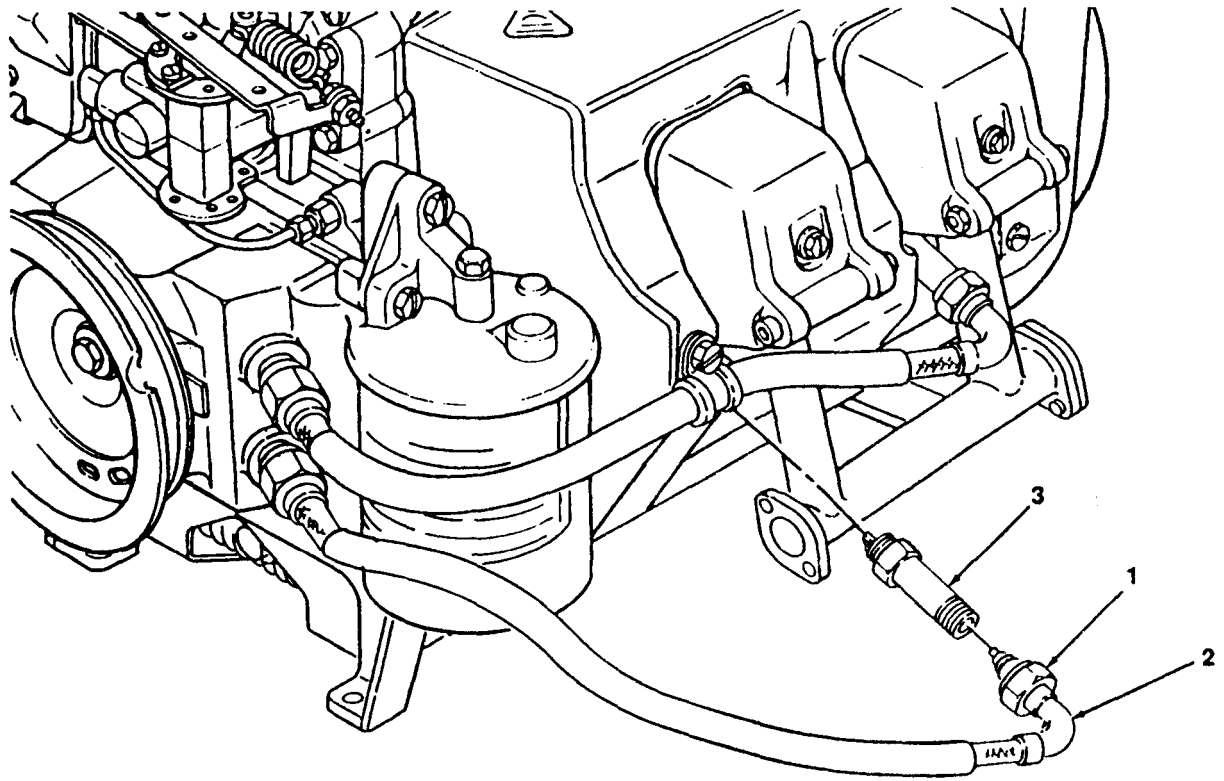

4868-021

Figure 4-22. Spark Plug, Removal and Installation.

4-29. **Preheater.**

This task covers: a. Removal b. Installation

INITIAL SETUP

Tools

General Mechanic's Tool Kit (Item 1, Appendix B)

a. Removal. (figure 4-23).

- (1) Loosen clamp (1) and remove duct (2) from preheater (3).
- (2) Remove clamp (4) from preheater (3) and remove preheater (3).

b. Installation. (figure 4-23)

- (1) Install preheater (3) and secure with clamp (4).
- (2) Install duct (2) and tighten clamp (1).

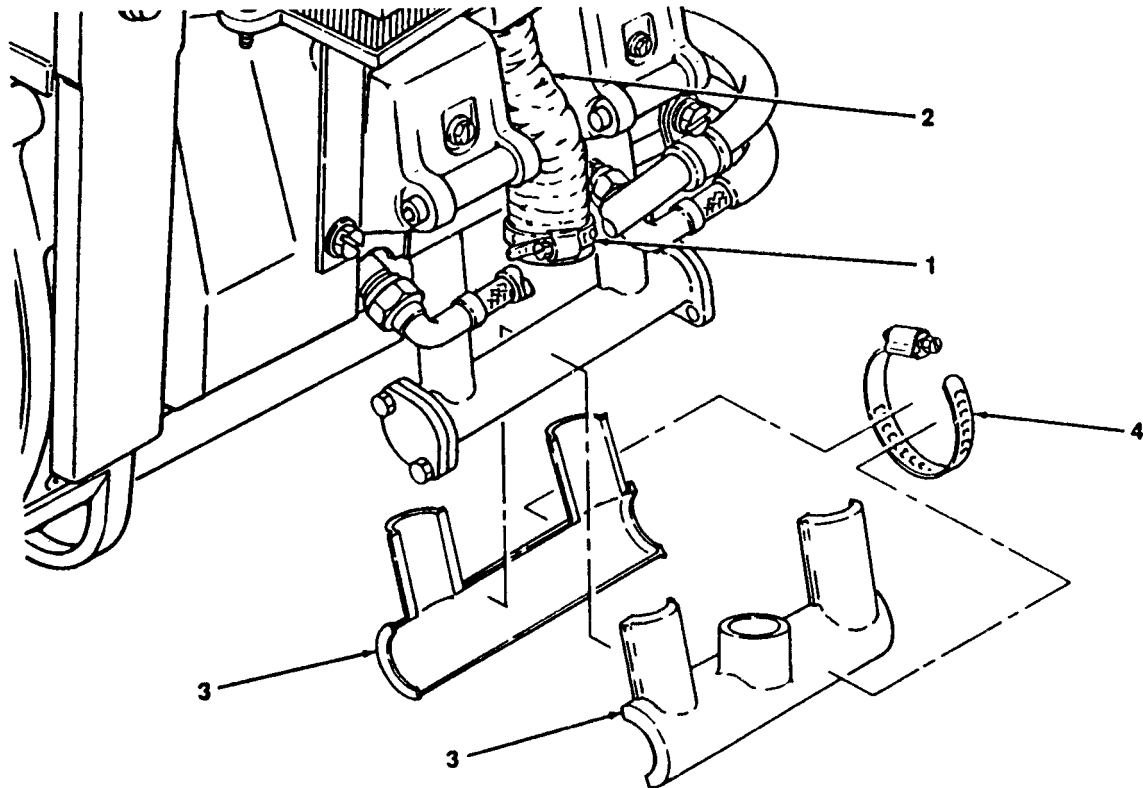

4868-022

Figure 4-23. Preheater, Removal and Installation.

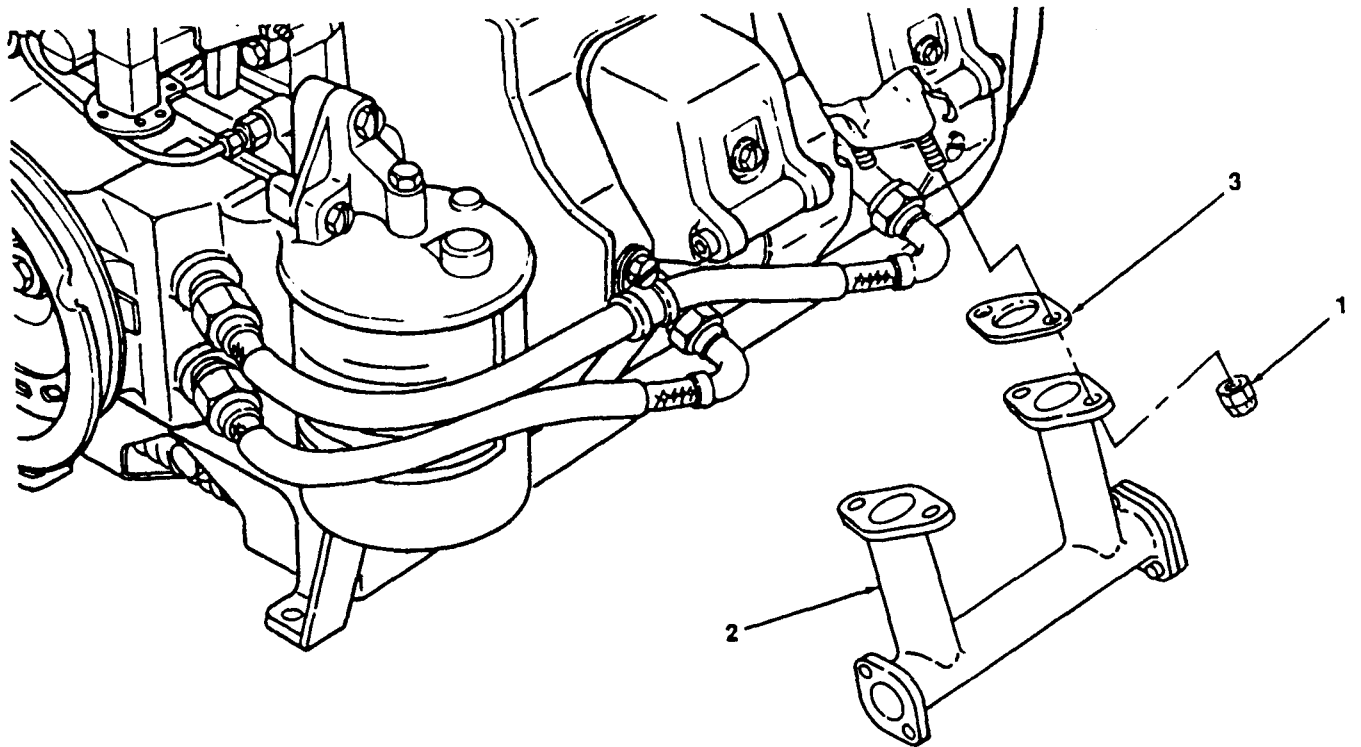

4867-023

Figure 4-24. Exhaust Manifold, Removal and Installation.

4-31. Relief Valve.

This task covers: a. Removal b. Inspection c. Installation

INITIAL SETUP

<i>Tools</i>	<i>Materials/Parts</i>
General Mechanic's Tool Kit (Item 1, Appendix B)	Rags, Wiping (Item 7, Appendix D) Solvent, Drycleaning (Item 8, Appendix D)

a. Removal. (figure 4-25).

- (1) Unscrew relief valve (1) from rocker cover (2).
- (2) Repeat step 1 for remaining relief valves.

b. Inspection. (figure 4-25)

WARNING

Drycleaning solvent PD-680 used to clean parts is potentially dangerous to personnel and property. Avoid repeated and prolonged skin contact. Do not use near open flame or excessive heat. Flash point of solvent is 100°F-138°F (38°C-60°C).

- (1) Clean relief valves in drycleaning solvent and dry thoroughly.
- (2) Inspect threads for signs of stripping and replace if threads are damaged.
- (3) Ensure pin (3) moves freely in and out. Replace if pin does not function properly.

c. Installation. (figure 4-25)

- (1) Install relief valve (1) in rocker cover (2).
- (2) Repeat step 1 for remaining relief valves.

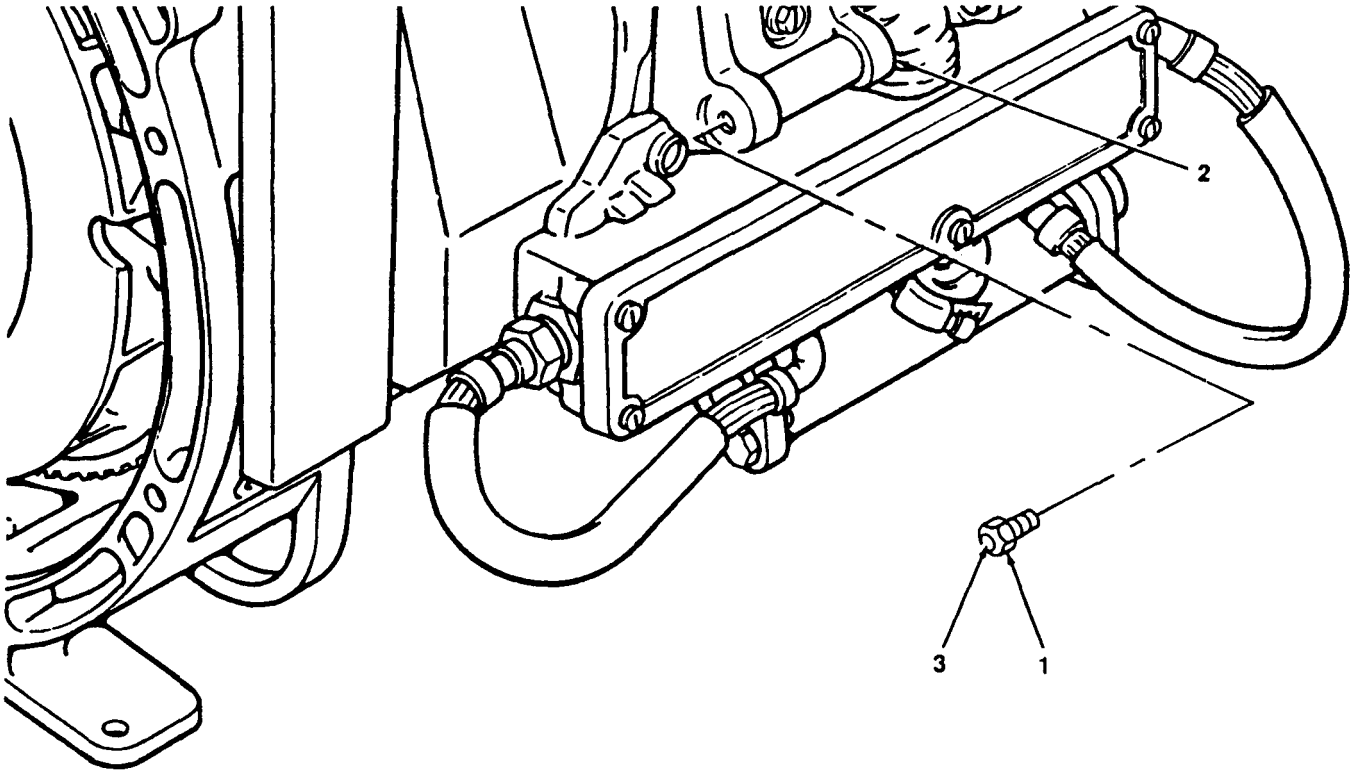

4868-027

Figure 4-25. Relief Valve, Removal Inspection and Installation.

4-32. **Rocker Box Cover.**

This task covers: a. Removal b. Repair c. Installation

INITIAL SETUP

Tools

Materials/Parts

General Mechanic's Tool Kit (Item 1, Appendix B)

Rags, Wiping (Item 7, Appendix D)
Solvent, Drycleaning (Item 8, Appendix D)
Gasket, Rocker Box Cover (NSN 5330-00-797-4642)

a. Removal. (figure 4-26).

- (1) Remove screw (1) and plastic washer (2) and remove rocker box cover (3) and gasket (4).
- (2) Repeat step 1 for remaining rocker box covers.

b. Repair.

WARNING

Drycleaning solvent PD-680 used to clean parts is potentially dangerous to personnel and property. Avoid repeated and prolonged skin contact. Do not use near open flame or excessive heat. Flash point of solvent is 100°F-I 38°F (38°C–60°C).

- (1) Clean rocker box covers in drycleaning solvent and dry thoroughly.
- (2) Repair any dents in rocker box covers and repaint as needed.
- (3) Inspect plastic washers and replace if cracked or otherwise damaged.

c. Installation. (figure 4-26)

- (1) Install rocker box cover (3) and new gasket (4) and secure with screw (1) and plastic washer (2).
- (2) Repeat step 1 for remaining rocker box covers.

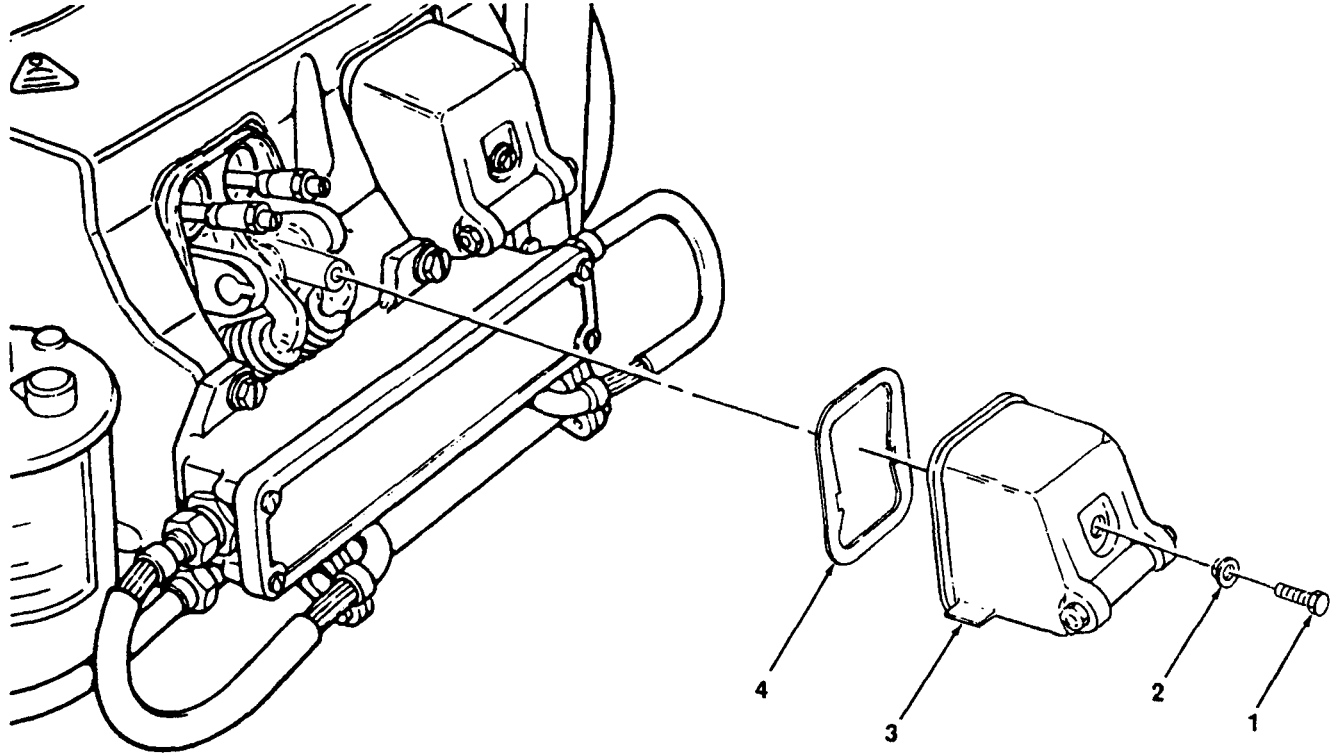

4868-028

Figure 4-26. Rocker Box Cover, Removal and Installation.

4-33. Winterization Shroud.

This task covers: a. Removal b. Repair c. Installation

INITIAL SETUP

Tools

Materials/Parts

General Mechanic's Tool Kit (Item 1, Appendix B)

Rags, Wiping (Item 7, Appendix D)

Solvent, Drycleaning (Item 8, Appendix D)

a. Removal. (figure 4-27).

- (1) Remove two screws (1) and washers (2).
- (2) Remove two screws (3) and washers (4) and remove winterization shroud (5).

b. Repair. (figure 4-27)

WARNING

Drycleaning solvent PD-680 used to clean parts is potentially dangerous to personnel and property. Avoid repeated and prolonged skin contact. Do not use near open flame or excessive heat. Flash point of solvent is 100°F-138°F (38°C-60°C).

- (1) Clean winterization shroud (5) with drycleaning solvent and dry thoroughly.
- (2) Repair any dents in winterization shroud and repaint as needed.

c. Installation. (figure 4-27)

- (1) Install winterization shroud (5) and secure with two screws (3) and washers (4).
- (2) Install two screws (1) and washers (2).

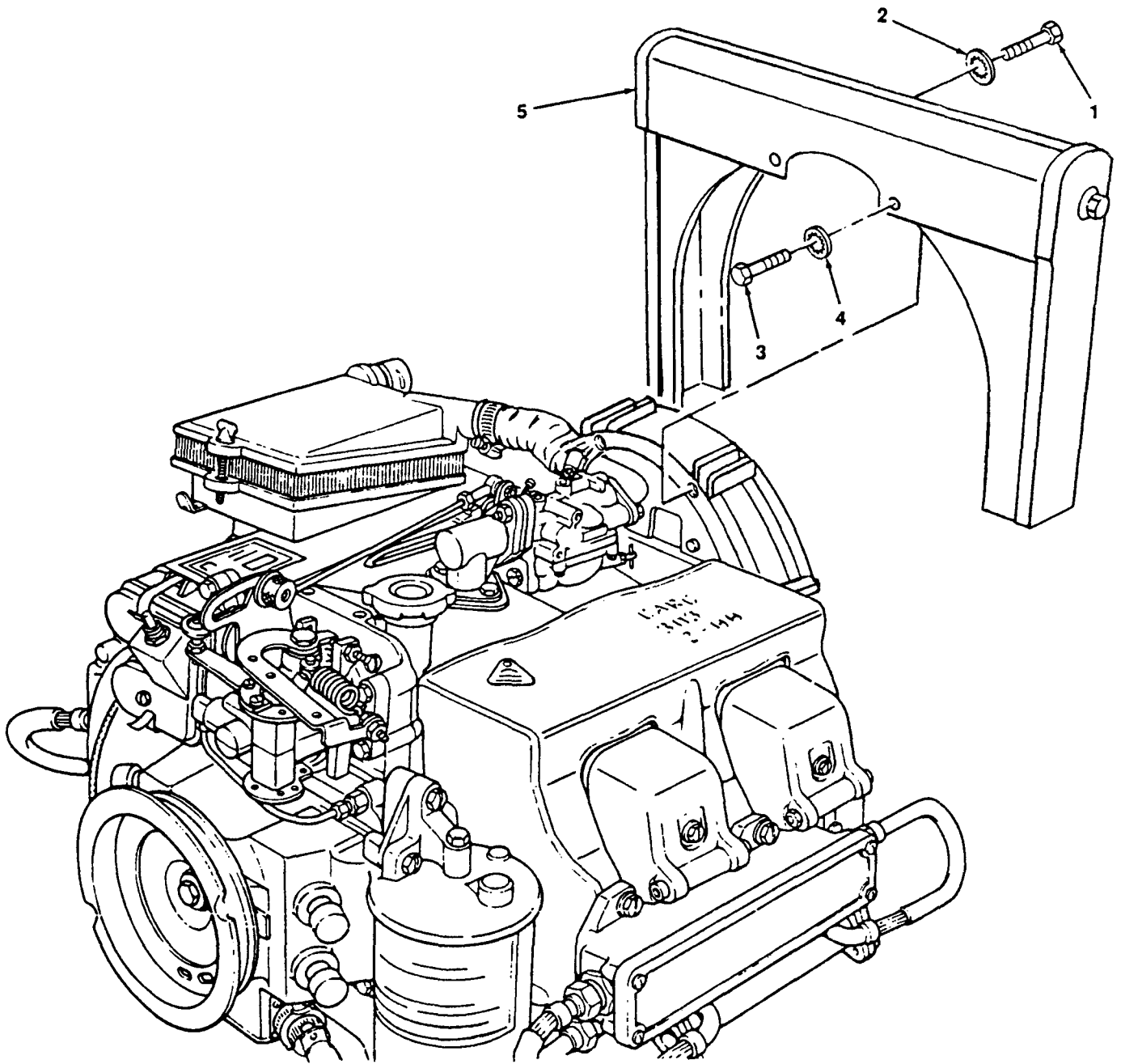

4868-024

Figure 4-27. Winterization Shroud, Removal and Installation.

4-34. Cylinder Head Cover, Internal Cover, and Baffles.

This task covers: a. Removal b. Repair c. Installation

INITIAL SETUP

<i>Tools</i>	Equipment Condition.
General Mechanic's Tool Kit (Item 1, Appendix B)	Rocker box covers removed (para. 4-32). Air cleaner removed when removing left side cylinder head cover, internal cover and baffles (para. 4-14).
<i>Materials/Parts</i>	
Rags, Wiping (Item 7, Appendix D)	
Solvent, Drycleaning (Item 8, Appendix D)	

NOTE

The procedures to remove, repair and install the cylinder covers, internal covers, and baffles are the same for left and right sides. The following procedures depict the right hand side.

a. Removal. (figure 4-28)

- (1) Loosen connector nuts (1), tag and remove high tension cables (2) from spark plugs (3).

NOTE

When removing cylinder head cover, internal cover, and baffles on engines equipped with breakerless ignition system, two of the three screws securing cylinder head covers secure ignition control unit. After removing those two screws, move ignition control unit out of way.

Make note of placement of loop clamps securing high tension cables.

- (2) Remove three screws (4), and washers (5) securing cylinder head cover (6), internal cover (7), and remove cylinder head cover (6) and internal cover (7).
- (3) Remove spring (8) and remove baffle (9).

b. Repair.

WARNING

Drycleaning solvent PD-680 used to clean parts is potentially dangerous to personnel and property. Avoid repeated and prolonged skin contact. Do not use near open flame or excessive heat. Flash point of solvent is 100°F-138°F (38°C-60°C).

- (1) Clean all parts in dry cleaning solvent, and dry thoroughly.
- (2) Repair all dents, and repaint parts as needed,

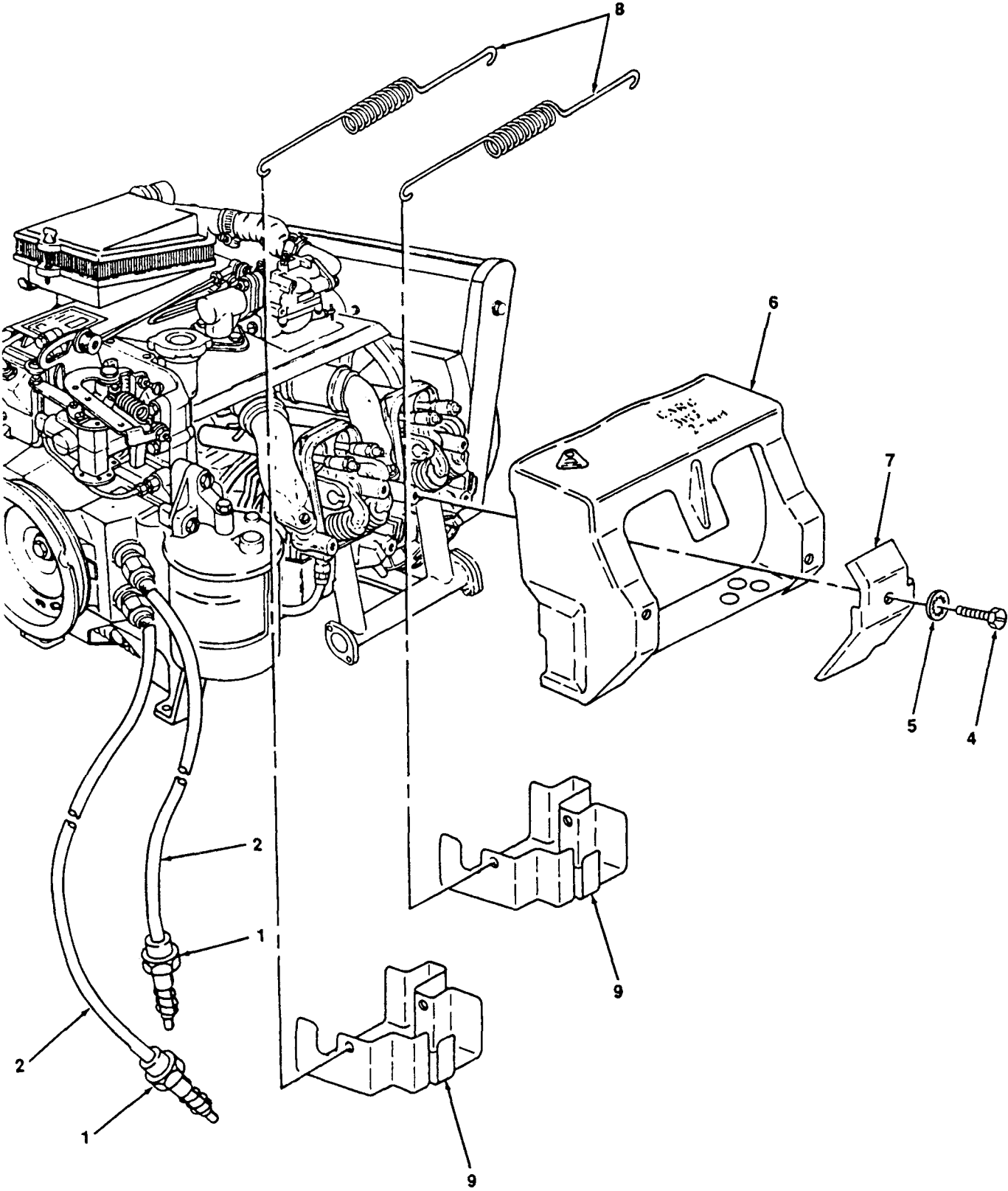

4868-025.1

Figure 4-28. Cylinder Head Cover, Internal Cover, and Baffles, Removal.

4-34. Cylinder Head Cover, Internal Cover, and Baffles (cont).

c. Installation. (figure 4-29)

(1) Install baffle (9) and secure with spring (8).

NOTE

When installing cylinder cover and internal cover on engines equipped with breakerless ignition system, use two of the three screws that secure cylinder cover and internal cover to secure ignition control unit.

(2) install loop clamps on high tension cables as noted.

(3) Install cylinder head cover (6), internal cover (7) and secure with three screws (4) and washers (5).

(4) Install high tension cables (2) and tighten connector nuts (1).

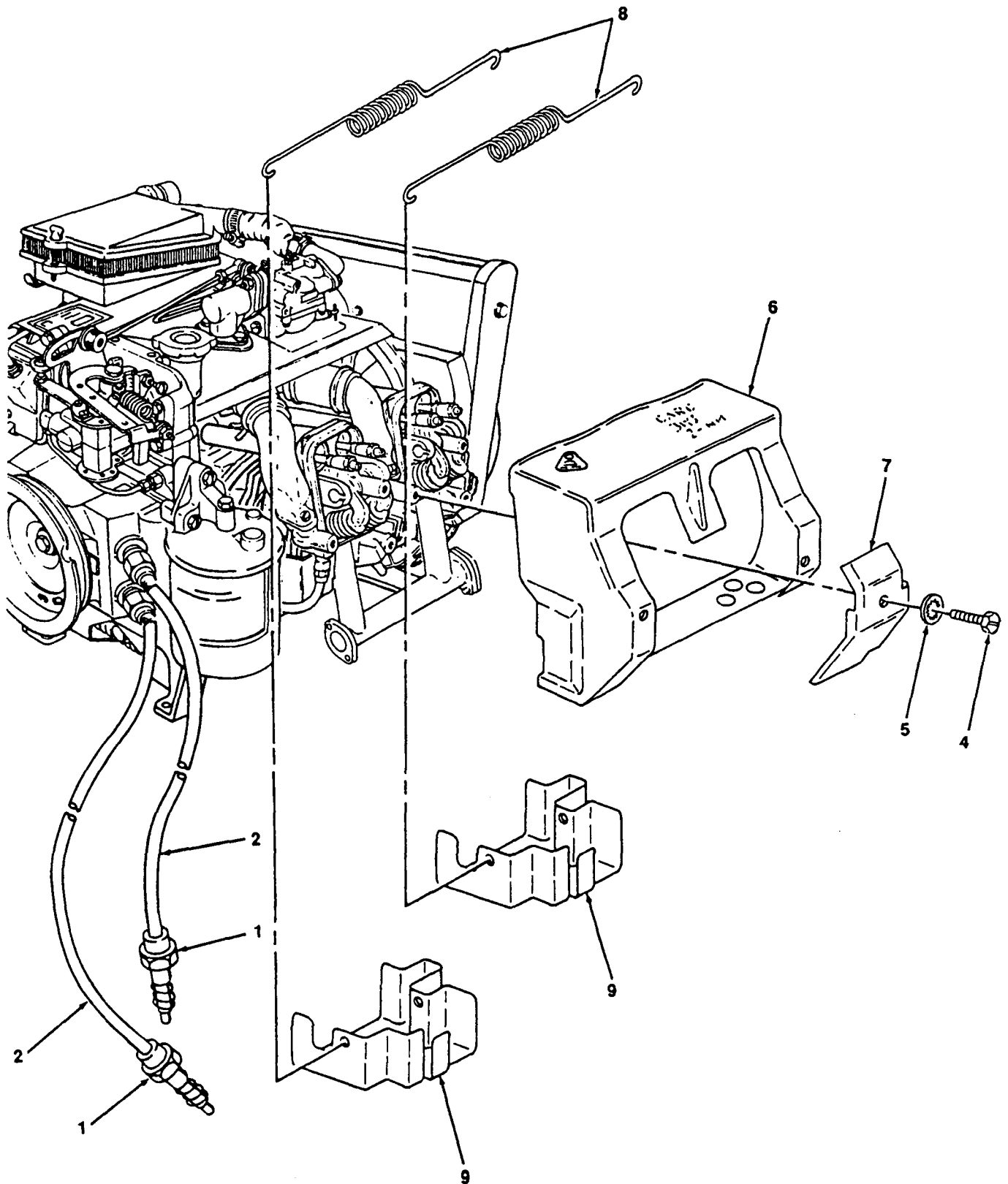

4868-025.2

Figure 4-29. Cylinder Head Cover, Internal Cover, and Baffles, Installation.

4-35. Oil Pan Cover.

This task covers: a. Removal b. Repair c. Installation

INITIAL SETUP

Tools

Materials/Parts

General Mechanic's Tool Kit (Item 1, Appendix B)

Rags, Wiping (Item 7, Appendix D)
Solvent, Drycleaning (Item 8, Appendix D)

a. Removal. (figure 4-30)

- (1) Remove three screws (1) and remove rear engine mount bracket (2).
- (2) Remove four screws (3) and washers (4) and remove oil pan cover (5).

b. Repair.

WARNING

Drycleaning solvent PD-680 used to clean parts is potentially dangerous to personnel and property. Avoid repeated and prolonged skin contact. Do not use near open flame or excessive heat. Flash point of solvent is 100°F-138°F (38°C-60°C).

- (1) Clean oil pan cover in drycleaning solvent, and dry thoroughly.
- (2) Repair all dents, and repaint as needed.

c. Installation. (figure 4-30).

- (1) Install oil pan cover (5) and secure with four screws (3) and washers (4).
- (2) Install rear engine mount (2) and secure with three screws (1).

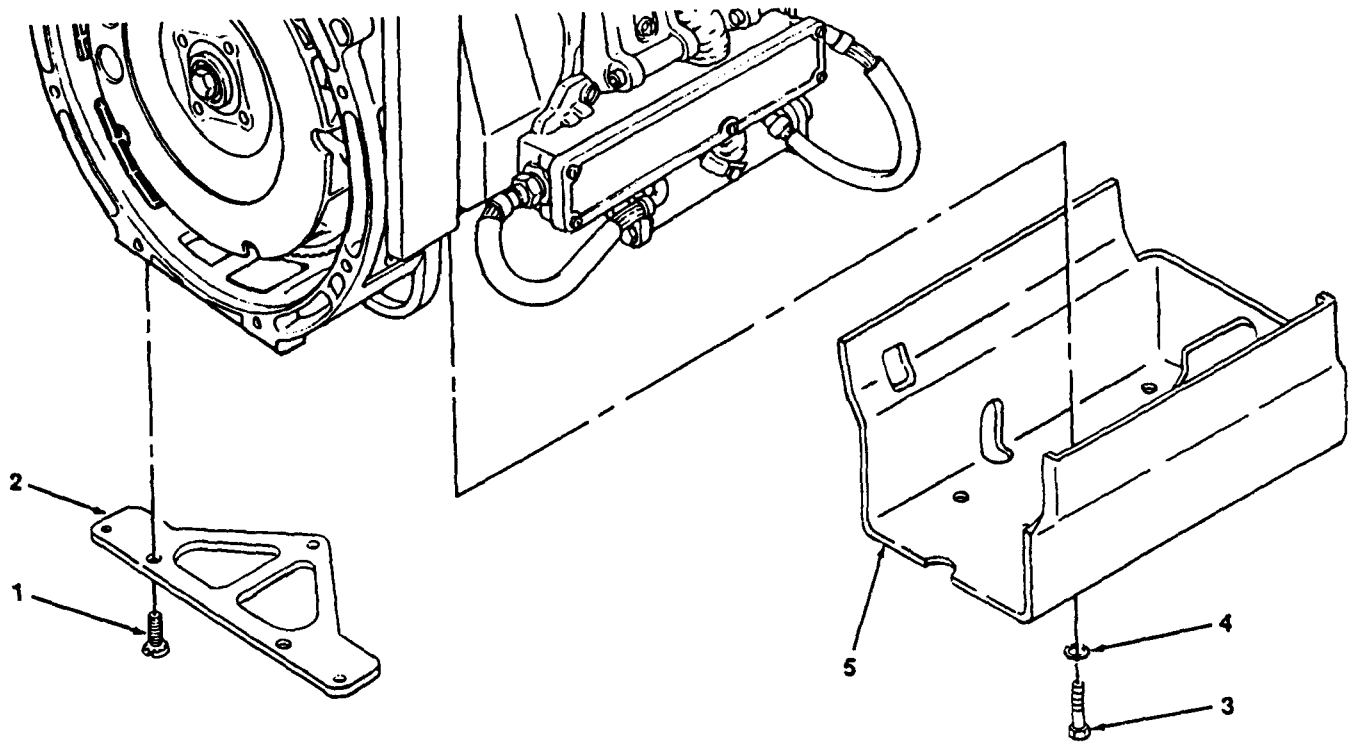

4868-026

Figure 4-30. Oil Pan Cover, Removal and Installation.

4-36. Top Cover.

This task covers: a. Removal b. Repair c. Installation

INITIAL SETUP

Tools

General Mechanic's Tool Kit (Item 1, Appendix B)

Materials/Parts

Rags, Wiping (Item 7, Appendix D)

Solvent, Drycleaning (Item 8, Appendix D)

Equipment Condition.

Right and left side cylinder head covers, internal covers removed (para. 4-34).

Carburetor adapter removed (para. 4-26).

Fuel line removed (para. 4-23).

a. Removal. (figure 4-31)

- (1) Remove adapter (1) from fuel pump (2),
- (2) Remove top cover (3).

b. Repair.

WARNING

Drycleaning solvent PD-680 used to clean parts is potentially dangerous to personnel and property. Avoid repeated and prolonged skin contact. Do not use near open flame or excessive heat. Flash point of solvent is 100°F-138°F (38°C-60°C).

- (1) Clean top cover in drycleaning solvent and dry thoroughly.
- (2) Repair any dents found in top cover and repaint as needed.

c. Installation. (figure 4-31).

- (1) Install top cover (3).
- (2) Install adapter (1) on fuel pump (2).

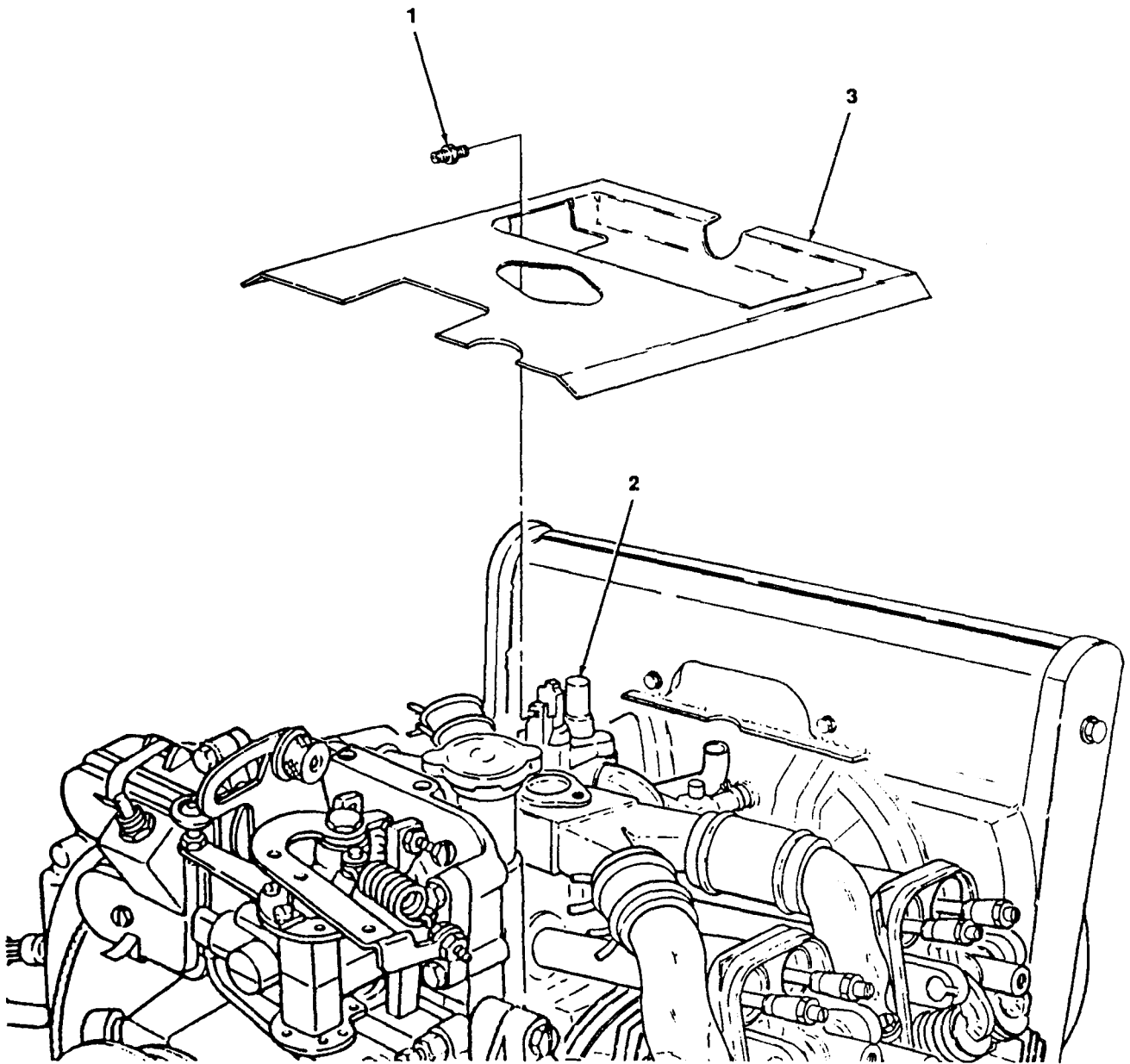

4868-029

Figure 4-31. Top Cover, Removal and Installation.

b. Replacement. (figure 4-33)

- (1) Remove two screws (1), washers (2), and nuts (3) and remove fuel pump (4) and gasket (5).
- (2) Clean all gasket mating surfaces and remove all old gasket material.
- (3) Install fuel pump (4) and new gasket (5), and secure with two screws (1), washers (2), and nuts (3). Torque nuts to 55-65 in. lb (9823-11609 gr cm).

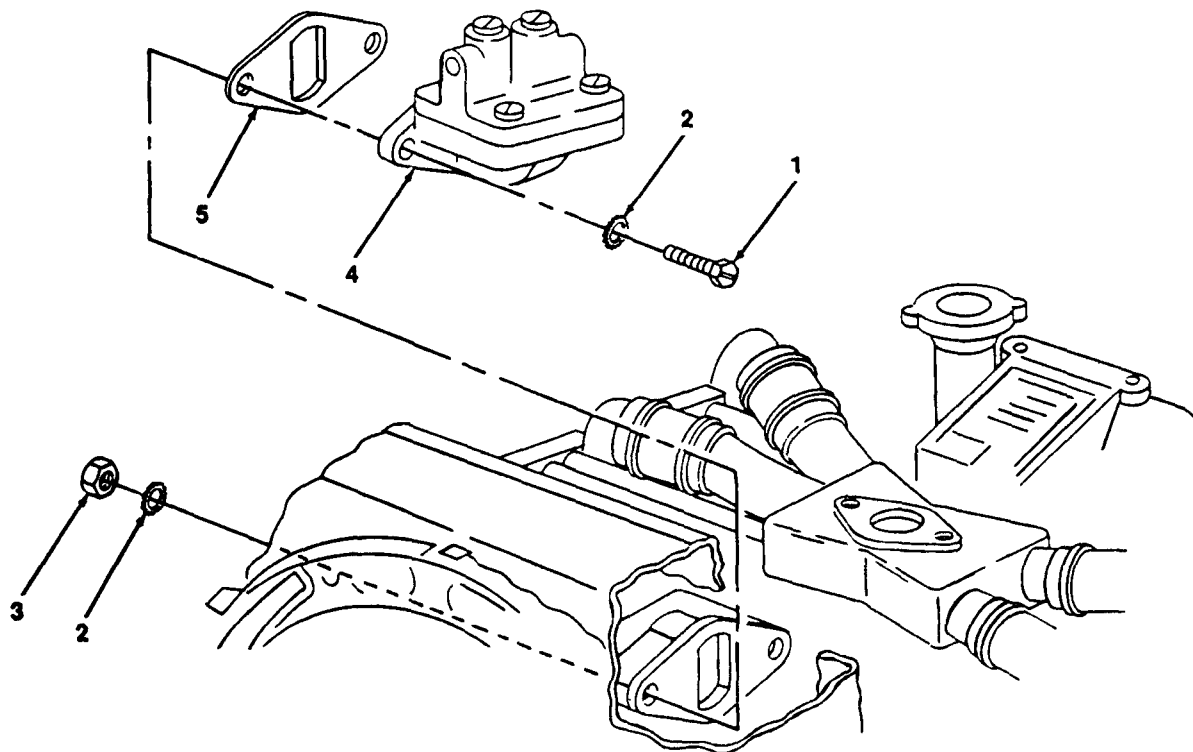

4868-031

Figure 4-33. Fuel Pump, Replacement.

4-38. Intake Manifold and Intake Manifold Hoses and Clamps.

This task covers: a. Removal b. Inspection c. Installation

INITIAL SETUP

Tools

Equipment Condition

General Mechanic's Tool Kit (Item 1, Appendix B)

Top cover removed (para. 4-36).

Materials/Parts

Rags, Wiping (Item 7, Appendix D)

Solvent, Drycleaning (Item 8, Appendix D)

a. Removal. (figure 4-34)

- (1) Loosen eight clamps (1) and move as far down intake manifold adapters (2) as possible.
- (2) Slide four hoses (3) as far up intake manifold (4) as possible.
- (3) Remove screw (5) and washer (6) and remove intake manifold (4).
- (4) Remove four hoses (3) from intake manifold (4).
- (5) Remove eight clamps (1) from intake manifold adapters (2).

b. Inspection. (figure 4-34)

WARNING

Drycleaning solvent PD-680 used to clean parts is potentially dangerous to personnel and property. Avoid repeated and prolonged skin contact. Do not use near open flame or excessive heat. Flash point of solvent is 100°F-138°F (38°C-60°C).

- (1) Clean intake manifold with drycleaning solvent, and dry thoroughly.
- (2) inspect intake manifold (4) and replace if cracked or otherwise damaged.
- (3) Inspect hoses (3) and replace if torn or otherwise damaged.

c. Installation. (figure 4-34).

- (1) Position eight clamps (1) on intake manifold adapters (2) as far down as possible.
- (2) Install four hoses (3) on intake manifold (4) as far up as possible.
- (3) Install intake manifold (4) and secure with screw (5) and washer (6).
- (4) Position four hoses (3) on intake manifold (4) and intake manifold adapters (2) and secure with eight clamps (1).

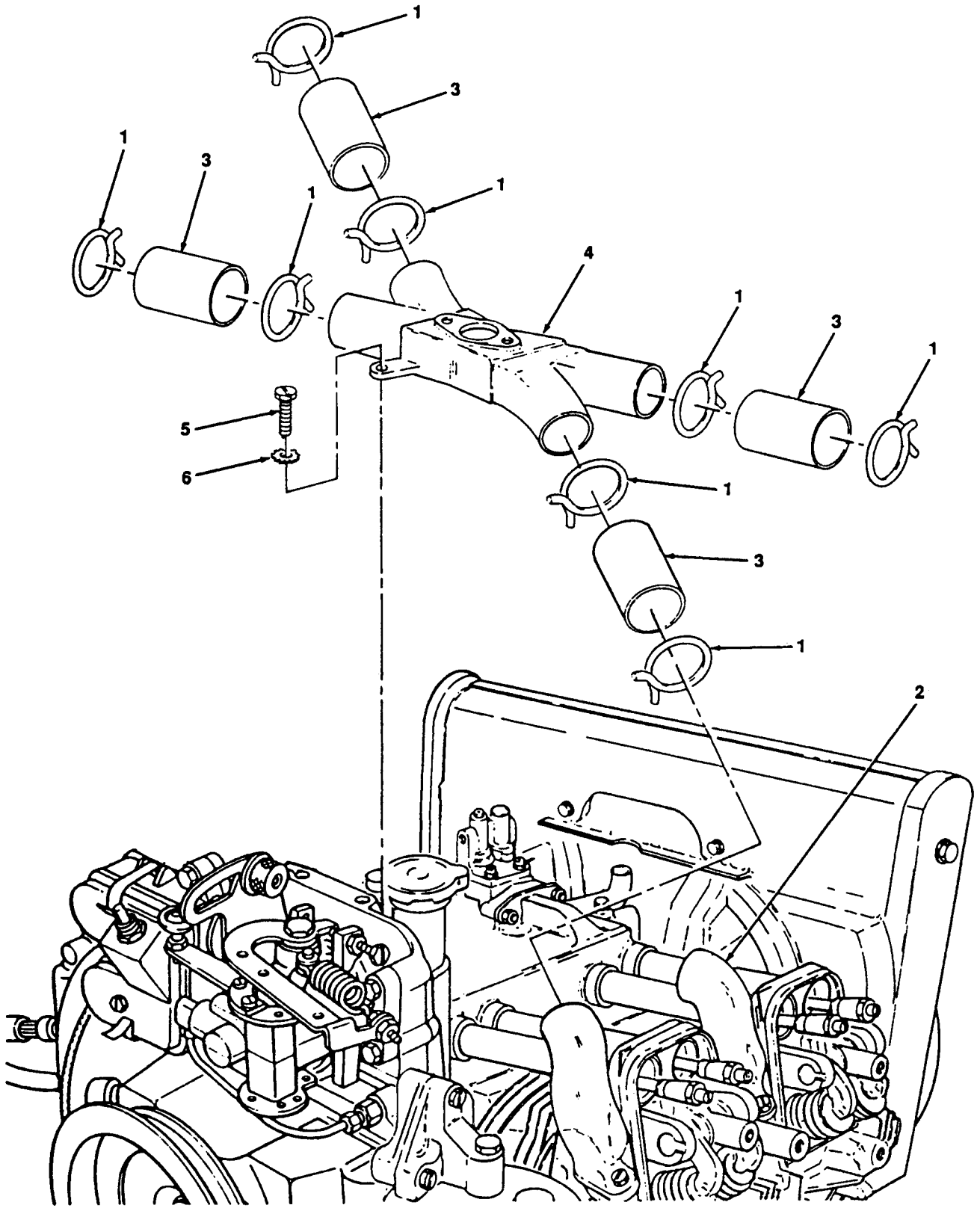

4868-032

Figure 4-34. Intake Manifold and Intake Manifold Hoses and Clamps, Removal, Inspection and Installation.

4-39. Intake Manifold Adapters.

This task covers: a. Removal b. Installation

INITIAL SETUP

<i>Tools</i>	<i>Equipment Condition</i>
General Mechanic's Tool Kit (Item 1, Appendix B) Wrench, Torque (NSN 5120-00-640-6364) (Item 2, Appendix B)	Top cover removed (para. 4-36).

Materials/Parts

Rags, Wiping (Item 7, Appendix D)
 Solvent, Drycleaning (Item 8, Appendix D)
 Gasket Intake Manifold (P/N 9786 E26-4)

a. *Removal.* (figure 4-35)

- (1) Remove two screws (1) and washers (2) securing intake manifold adapter (3) to cylinder head (4).
- (2) Loosen clamp (5) and remove intake manifold adapter (3) and gasket (6).
- (3) Repeat steps 1 and 2 for remaining intake manifold adapters.

WARNING

Drycleaning solvent PD-680 used to clean parts is potentially dangerous to personnel and property. Avoid repeated and prolonged skin contact. Do not use near open flame or excessive heat. Flash point of solvent is 100°F–138°F (38°C-60°C).

- (4) Clean intake manifold adapters in drycleaning solvent, and dry thoroughly.
- (5) Inspect intake manifold adapters and replace if cracked or otherwise damaged.

b. *Installation.* (figure 4-35)

- (1) Insure all gasket mating surfaces are clean and free of old gasket material.
- (2) Loosen clamp (5) and install intake manifold adapter (3) in intake hose (7) and tighten clamp (5).
- (3) Install intake manifold adapter (3) and new gasket (6) and secure with two screws (1) and washers (2). Torque screws to 45-50 in. lb (8037-8930 gr cm).
- (4) Repeat steps 1 through 3 for remaining intake manifold adapters.

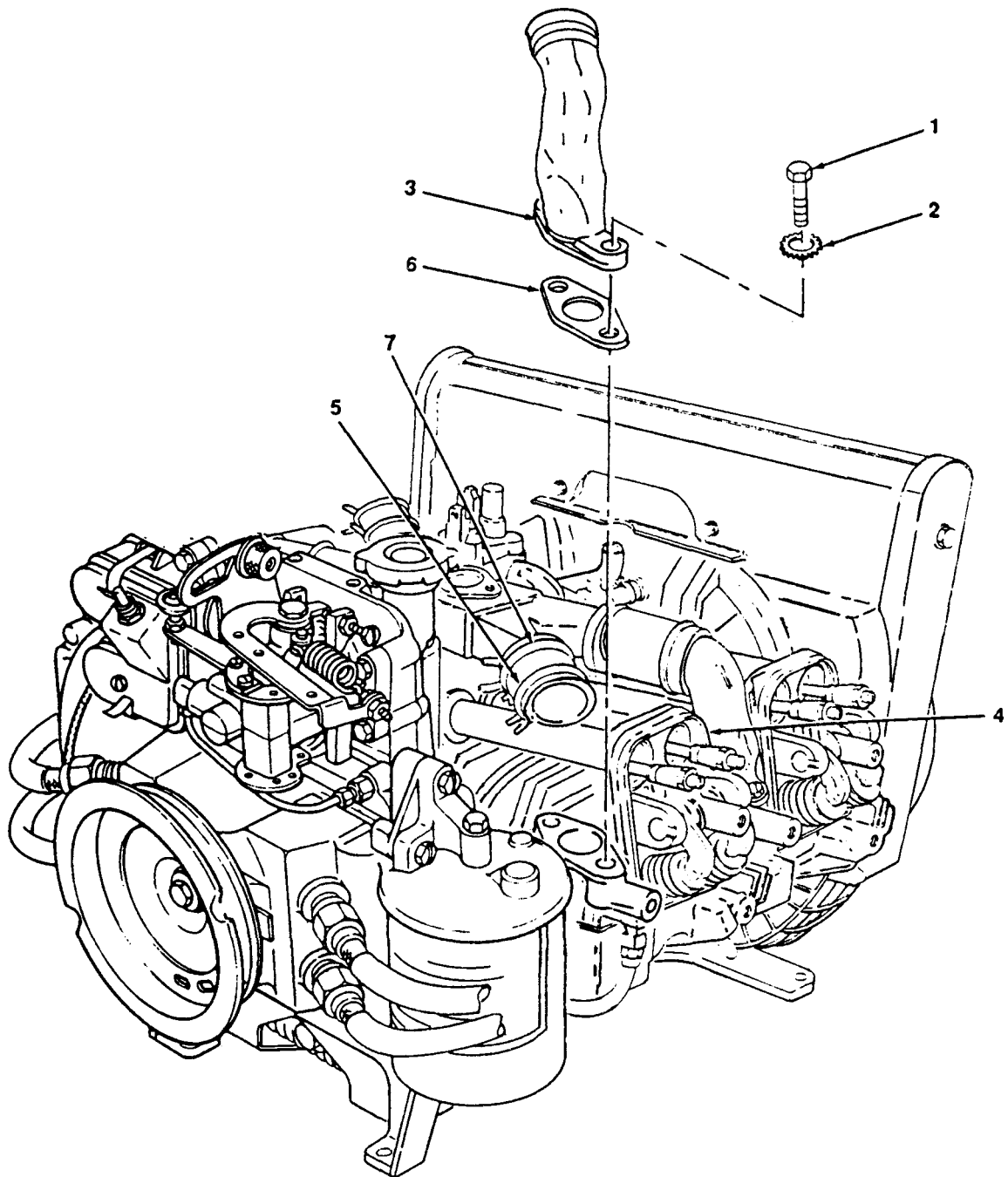

4868-033

Figure 4-35. Intake Manifold Adapters, Removal and Installation.

4-40. Breather Box Cover and Breather Tube.

This task covers: a. Removal b. Inspection c. Installation

INITIAL SETUP

Tools

General Mechanic's Tool Kit (Item 1, Appendix B)

Materials/Parts

Rags, Wiping (Item 7, Appendix D)
Solvent, Drycleaning (Item 8, Appendix D)
Gasket, Breather Box Cover (P/N 13206EO017)

Materials/Parts (cont)

Gasket, Metallic (NSN 5330-00-752-8605)
Packing, Preformed (NSN 5330-00-901-7196)

Equipment Condition

Intake manifold removed (para. 4-38).

a. Removal. (figure 4-36)

- (1) Remove nut (1) and remove breather tube (2).
- (2) Remove two screws (3) and washers (4) and remove breather box cover (5) and gasket (6).
- (3) Loosen clamp (7) and remove adapter tube (8).
- (4) Remove gasket (9) and preformed packing (10).

b. Inspection. (figure 4-36)

WARNING

Drycleaning solvent PD-680 used to clean parts is potentially dangerous to personnel and property. Avoid repeated and prolonged skin contact. Do not use near open flame or excessive heat. Flash point of solvent is 100°F-138°F (38°C-60°C).

- (1) Clean breather tube (2) and breather box cover (5) with drycleaning solvent, and dry thoroughly.
- (2) Clean adapter tube (8) in detergent and water.
- (3) inspect breather tube (2), breather box cover (5), adapter tube (8), gasket (9), nut (1), and preformed packing (10), for wear and replace if worn or otherwise damaged.
- (4) Inspect breather box (11) and clean as needed.

c. Installation. (figure 4-36)

- (1) Install adapter tube (8) and secure with clamp (7).
- (2) Install breather tube (2), gasket (10), preformed packing (9) and secure with nut(1)
- (3) Install breather box cover (5) and new gasket (6) and secure with two screws (3) and washers (4).

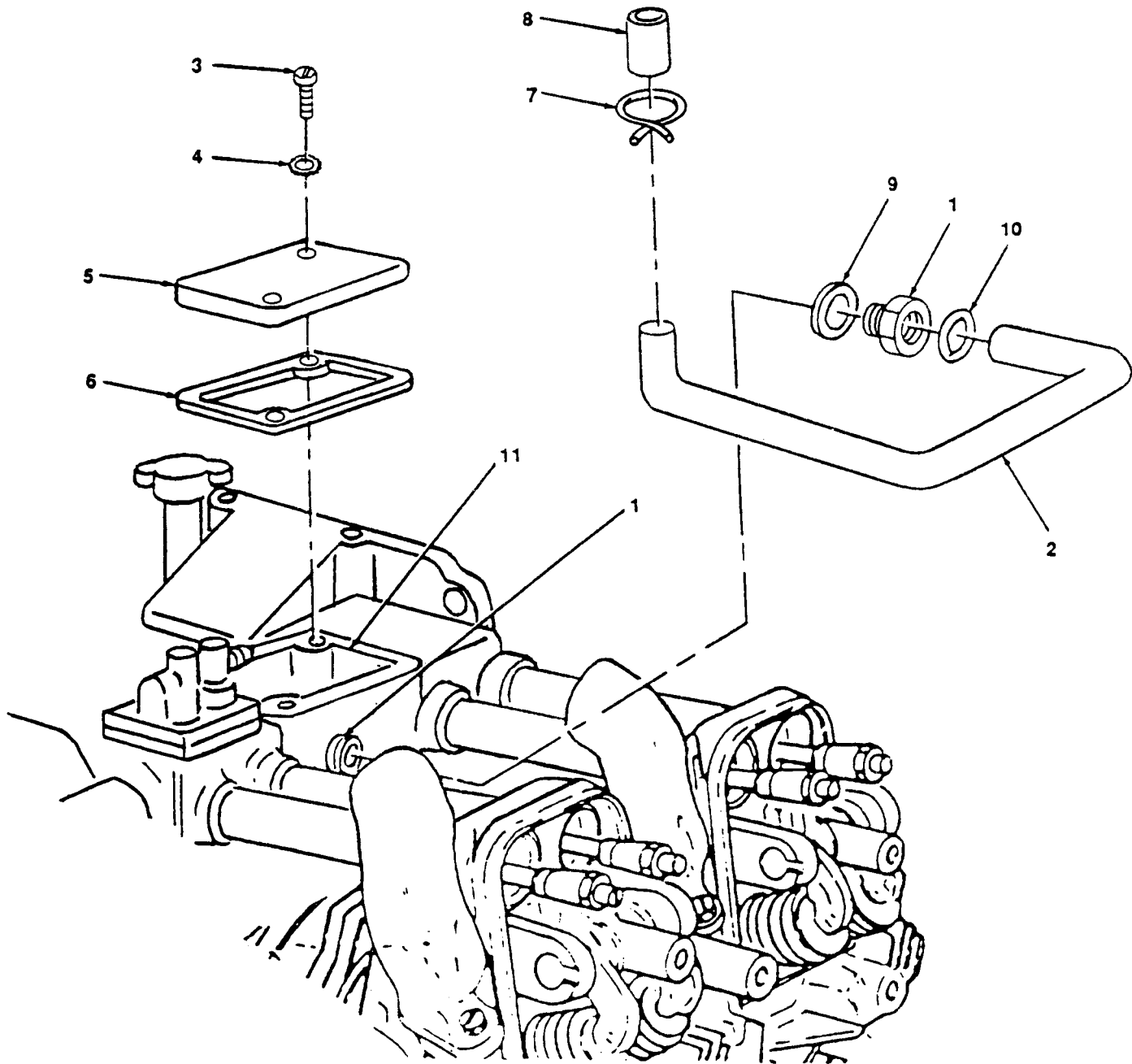

4868-033.1

Figure 4-36. Breather Box Cover and Breather Tube, Removal, Inspection and Installation.

4-41. Oil Filter.

This task covers: a. Replacement (Element filter) b. Replacement (Spin or filter type)

INITIAL SETUP

Tools

General Mechanic's Tool Kit (Item 1, Appendix B)
Oil Filter Wrench (NSN 5120-00-865-0933)
(Item 2, Appendix B)

Materials/Parts

Rags, Wiping (Item 7, Appendix D)
Solvent, Drycleaning (Item 8, Appendix D)

Materials/Patts (cont)

Element, Oil Filter with Gasket
(NSN 2940-00-580-6302)
Oil Filter, Spin On (P/N 13226E6189)
Oil, Engine (NSN 9150-01-152-4117) (Item 3,
Appendix D)

a. Replacement (Element Filter). (figure 4-37)

- (1) Remove either drain plug (1) or (2) and washer rolled (3) and drain oil into a suitable container.
- (2) Loosen screw (4) and remove shell (5) and gasket (6).
- (3) Remove element (7) from shell (5), and pour remaining oil into suitable container.

WARNING

Drycleaning solvent PD-680 used to clean parts is potentially dangerous to personnel and property. Avoid repeated and prolonged skin contact. Do not use near open flame or excessive heat. Flash point of solvent is 100°F-138°F (38°C-60°C).

- (4) Clean shell (5) and drain plug (1) or (2) with drycleaning solvent, and dry thoroughly.
- (5) Inspect shell (5) for cracks, replace if cracked or otherwise damaged.
- (6) Inspect drain plug (1) or (2) and washer(3) for wear and replace if worn or otherwise damaged.
- (7) Install new element (7) in shell (5).
- (8) Install shell (5) and new gasket (6) and secure with screw (4).
- (9) Install drain plug (1) or (2) and washer (3).
- (10) Fill crankcase (refer to LO9-2805-203-14 for proper grade) and check level.
- (11) Start engine, para. 2-9, and run for five minutes and check for leaks.
- (12) Stop engine, para. 2-10, recheck engine oil, add oil as needed.

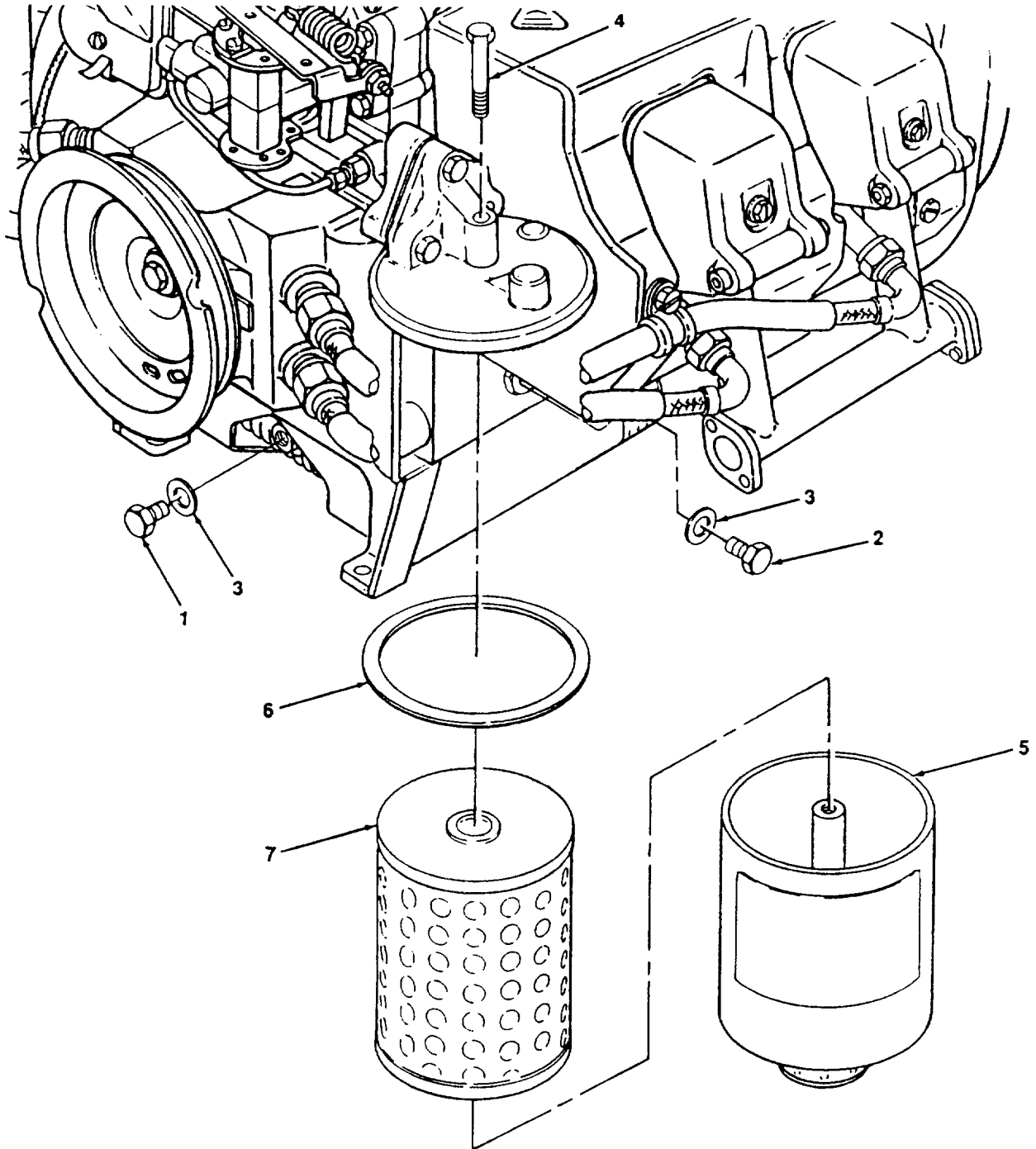
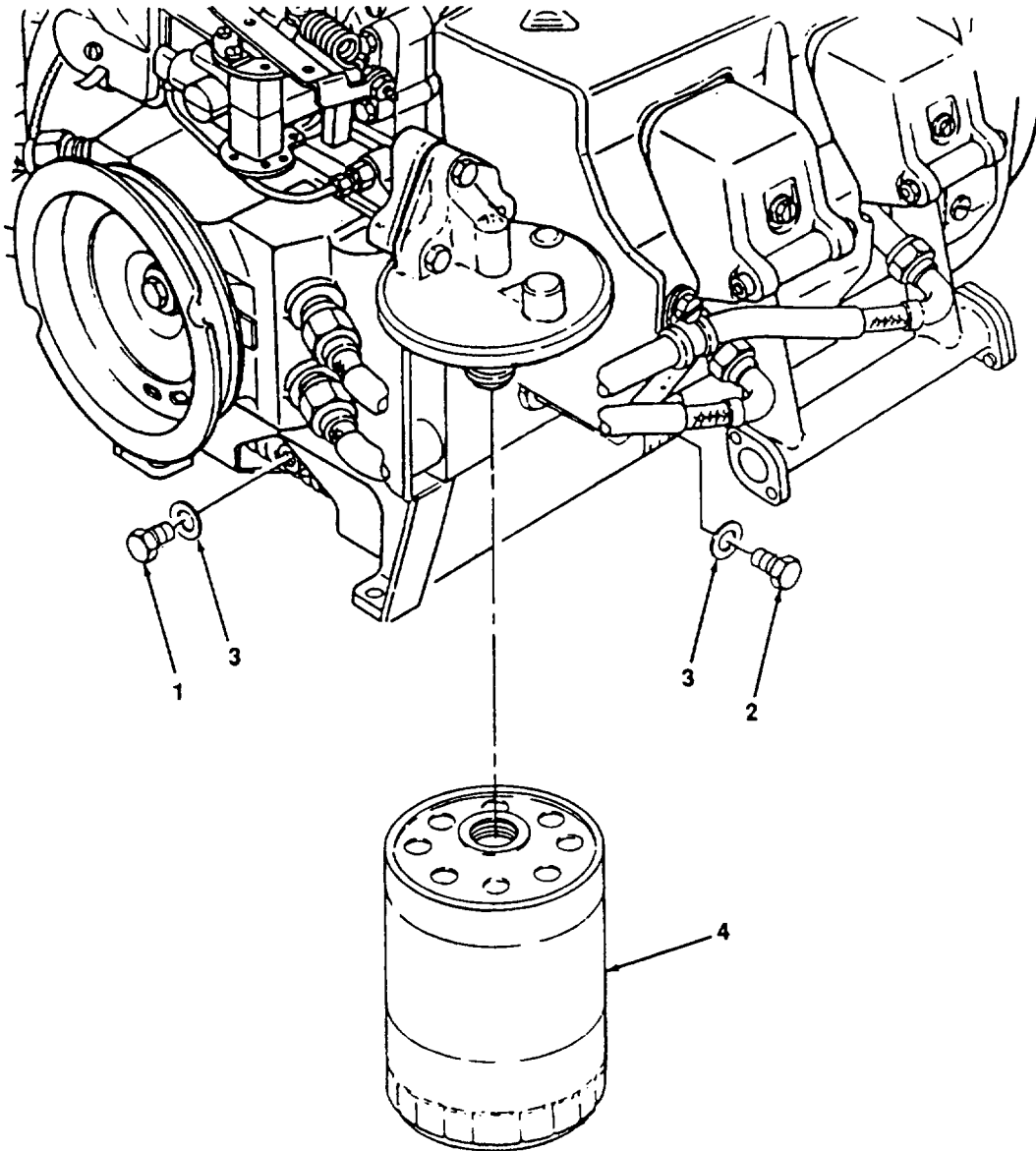

Figure 4-37. Oil Filter (Element Filter), Replacement.

4-41. **Oil Filter (cont).**

b. **Replacement (Spin on Filter)**. (figure 4-38)

- (1) Remove drain plug (1) or (2) and washer (3) and drain oil into suitable container.
- (2) Using oil filter wrench, remove oil filter (4).
- (3) Oil surface of gasket on new oil filter sparingly, install oil filter (4) until seated, then 3/4 turn more.
- (4) install drain plug (1) or (2) and washer (3).
- (5) Fill crankcase (refer to LO 9-2805-203-12 for proper grade) and check oil level.
- (6) Start engine, para. 2-9, run for five minutes and check for leaks.
- (7) Stop engine, para. 2-10, recheck oil level and add oil if needed.



4868-042

Figure 4-38. Oil Filter (Spin on Filter), Replacement.

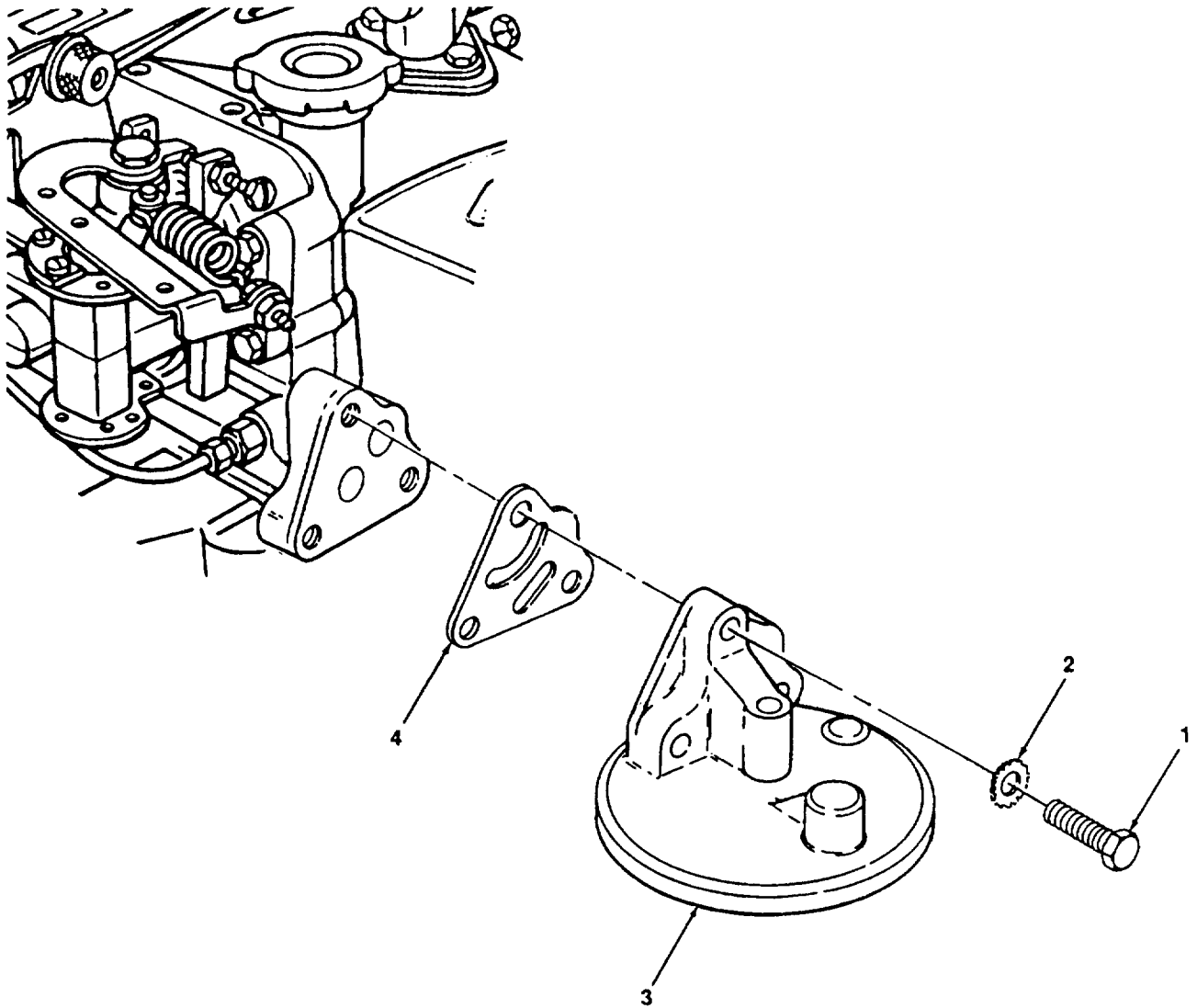

4868-043

Figure 4-39. Oil Filter Head, Removal and Installation.

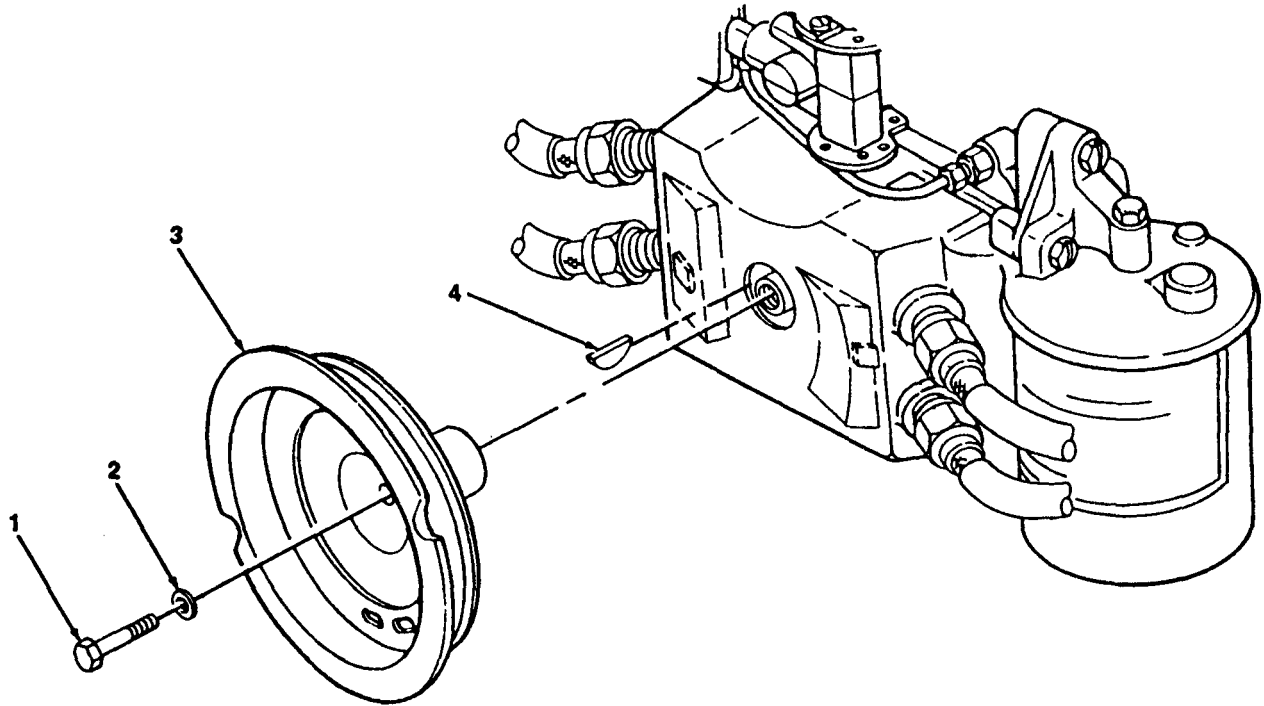

4868-045

Figure 4-40. Starter Rope Pulley, Removal and Installation.

4-44. Breaker Point Cover.

This task covers:

a. Removal (breaker point ignition)	d. Removal (breakerless ignition)
b. Inspection (breaker point ignition)	e. installation (breakerless ignition)
c. Installation (breaker point ignition)	

INITIAL SETUP

Tools

Materials/Parts

General Mechanic's Tool Kit (Item 1, Appendix B)

Gasket, Breaker Point Cover Mounting
(P/N 13206E0434)

a. Removal Breaker point Ignition. (figure 4-41)

Unsnap two clips (1) and remove breaker point cover (2) and gasket (3).

NOTE

Some engines are equipped with grounding straps connected to cover. Tag and remove grounding strap as needed.

b. Inspection (Breaker Point Ignition). (figure 4-41)

Inspect gasket (3) and replace if torn or otherwise damaged.

c. Installation (Breaker Point Ignition). (figure 4-41)

NOTE

Connect grounding strap to cover as tagged.

Install breaker point cover (2) and gasket (3) and secure with two clips (1).

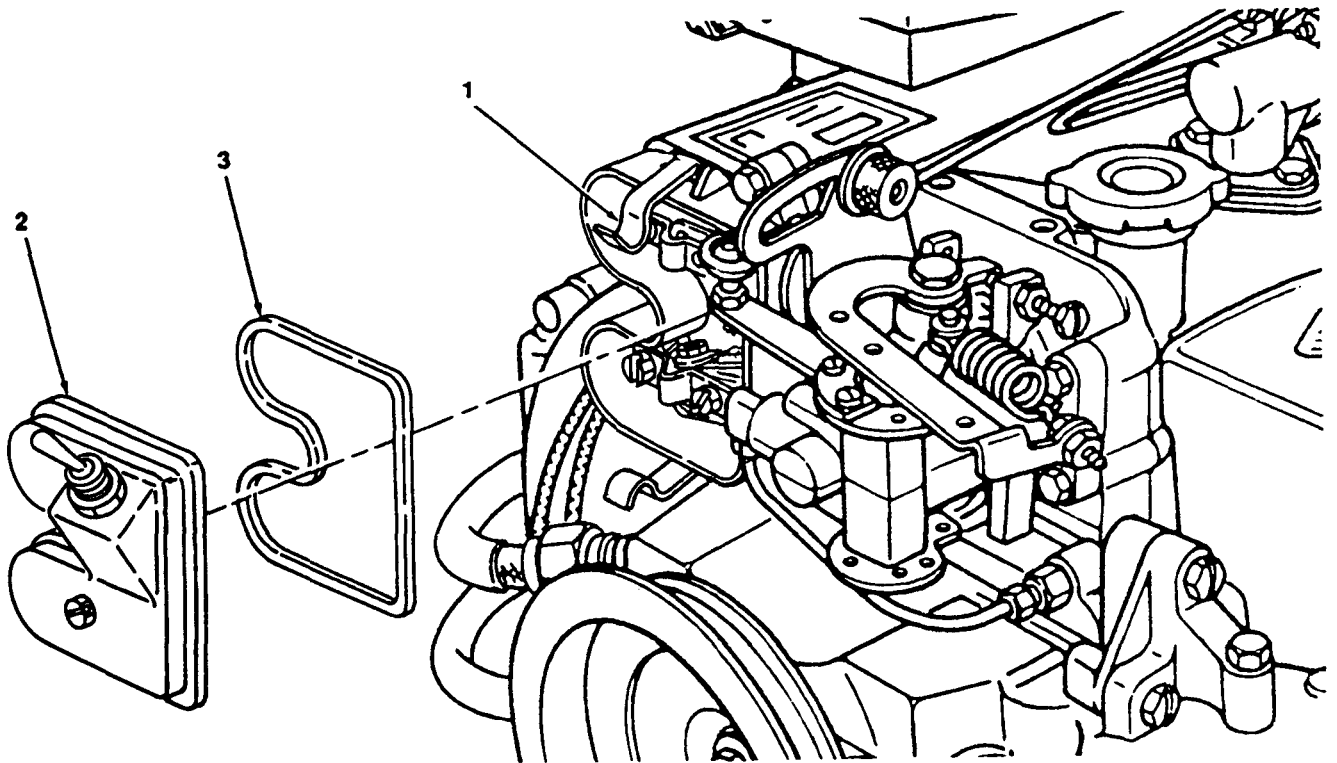

4868-046

Figure 4-41. Breaker Point Cover, Removal and Installation.

4-44. **Breaker Point Cover (cont).**

d. Removal (Breakerless Ignition). (figure 4-42)

(1) Unsnap two clips (1) securing cover (2).

(2) Tag and disconnect electrical leads from ignition switch (3), and remove cover (2) and gasket (4).

e. Installation (Breakerless Ignition). (figure 4-42)

(1) Connect leads as tagged to ignition switch (3).

(2) Install cover (2) and gasket (4) and secure with two clips (1).

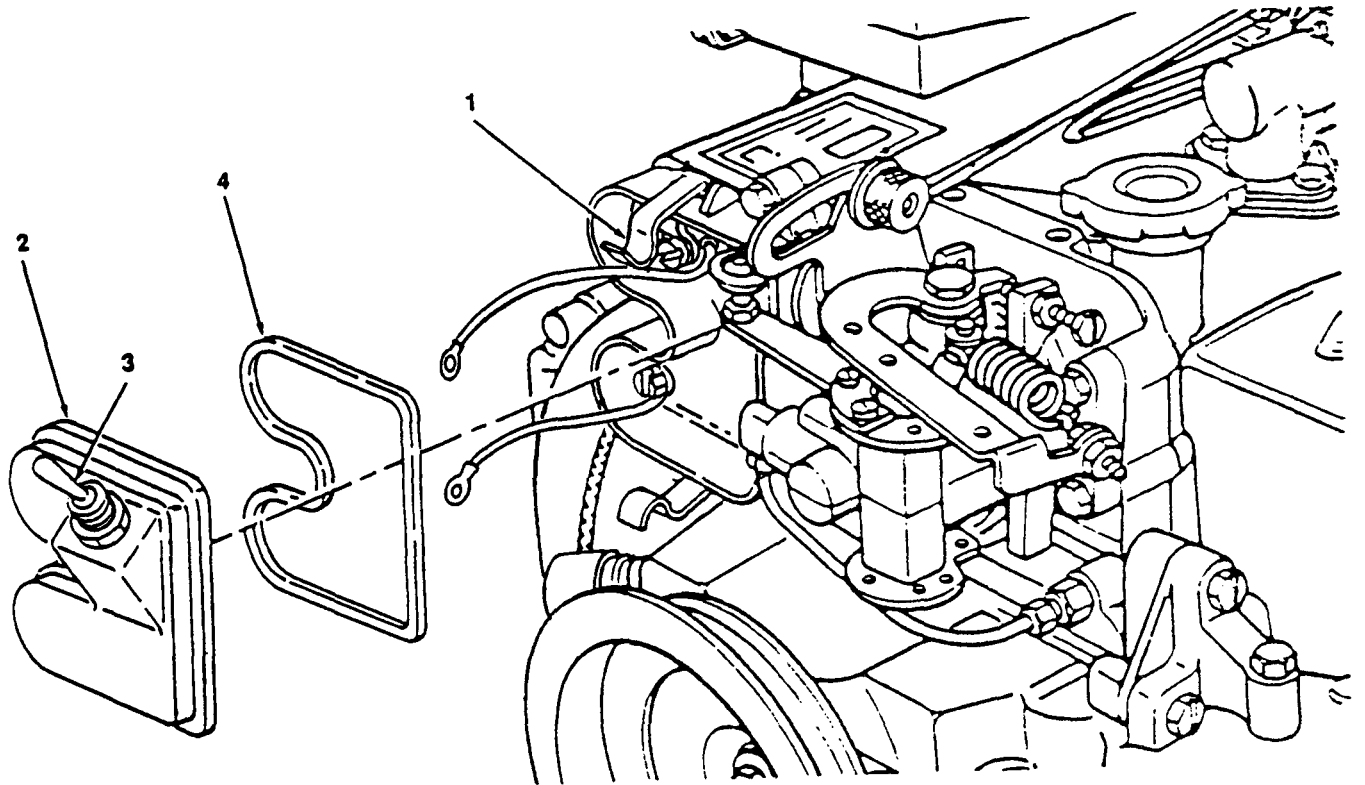

4868-051

Figure 4-42. Cover, Removal and Installation.

4-45. Ignition Switch.

This task covers: a. Test b. Removal c. Installation

INITIAL SETUP

Tools

Equipment Condition

General Mechanic's Tool Kit (Item 1, Appendix B)
Multimeter (NSN 6625-01-139-2512) (Item 2,
Appendix B)

Breaker point cover removed (para. 4-44).

a. Test (figure 4-43)

- (1) Connect one lead of multimeter to ignition switch terminal (1).

NOTE

Switch OFF position is ignition switch RUN position. Switch ON position is ignition switch OFF position.

- (2) Set ignition switch (2) to RUN.
- (3) Connect second lead of multimeter to ignition switch terminal (3).
- (4) Continuity should not be present, if it is, replace switch.
- (5) Set ignition switch to OFF, continuity should now be present, if not, replace switch.

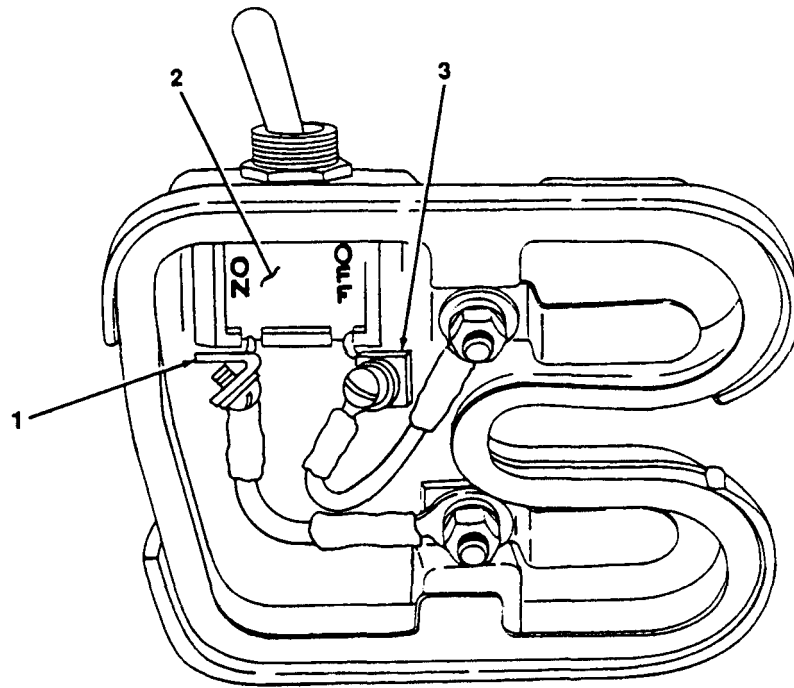

4868-047

Figure 4-43. Ignition Switch, Test.

4-45. **Ignition Switch (cont).**

b. Removal. (figure 4-44)

NOTE

Step 1 is for engines equipped with breaker point ignitions.

- (1) Tag and remove leads from ignition switch (1).
- (2) Remove nut (2) and washer (3) and remove ignition switch (1).

c. Installation. (figure 4-44)

NOTE

When installing the ignition switch, the OFF position on the switch corresponds to the RUN position on the engine.

- (1) Install ignition switch (1) and secure with nut (2) and washer (3).

NOTE

Step 2 is for engines equipped with breaker point ignition.

- (2) Connect leads to switch (1) as tagged.

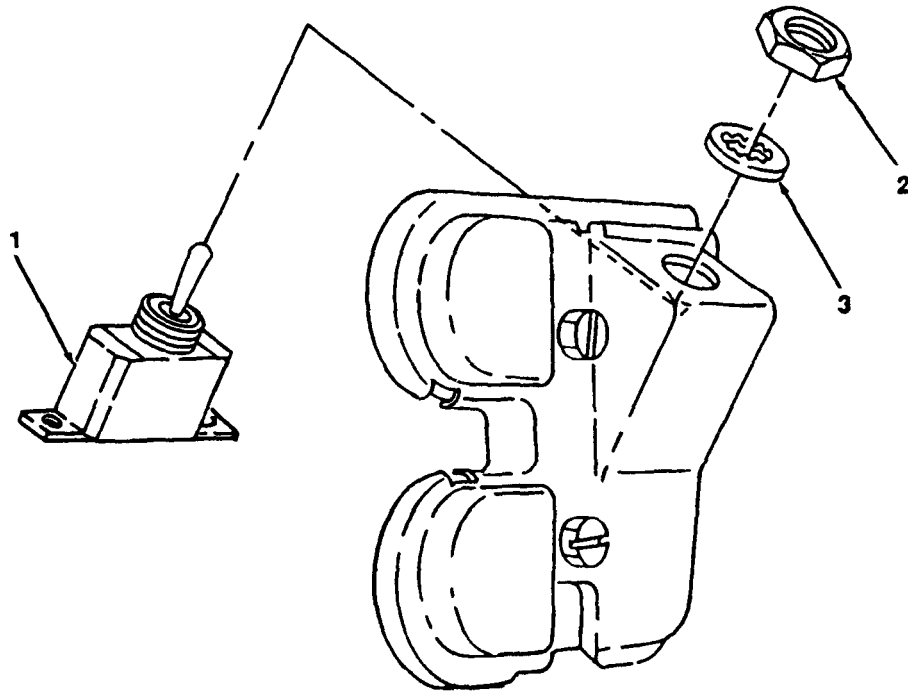

4868-048

Figure 4-44. Ignition Switch, Removal and Installation.

4-46. **Condenser (Breaker Point Ignition).**

This task covers: Replacement

INITIAL SETUP

Tools

Equipment Condition

General Mechanic's Tool Kit (Item 1, Appendix B)

Breaker point cover removed (para. 4-44).

Replacement. (figure 4-45)

NOTE

The replacement procedures are the same for both condensers.

- (1) Remove two screws (1) and washers (2) and remove connector bar (3).
- (2) Remove two screws (4) and washers (5) securing two cable clamps (6) and remove cable clamps (6).
- (3) Remove nut (7) and lockwasher (8) and tag and remove condenser lead (9) from noise suppression filter (10).
- (4) Remove screw (11) and washer(12) and remove condenser (13).
- (5) Install condenser (13) and secure with screw (11) and washer (12).
- (6) Connect condenser lead (9) to noise suppression filter (10) and secure with nut (7) and washer(8).
- (7) Install two cable clamps (6) and secure with two screws (4) and washers (5).
- (8) Install connector bar (3) and secure with two screws (1) and washers (2).

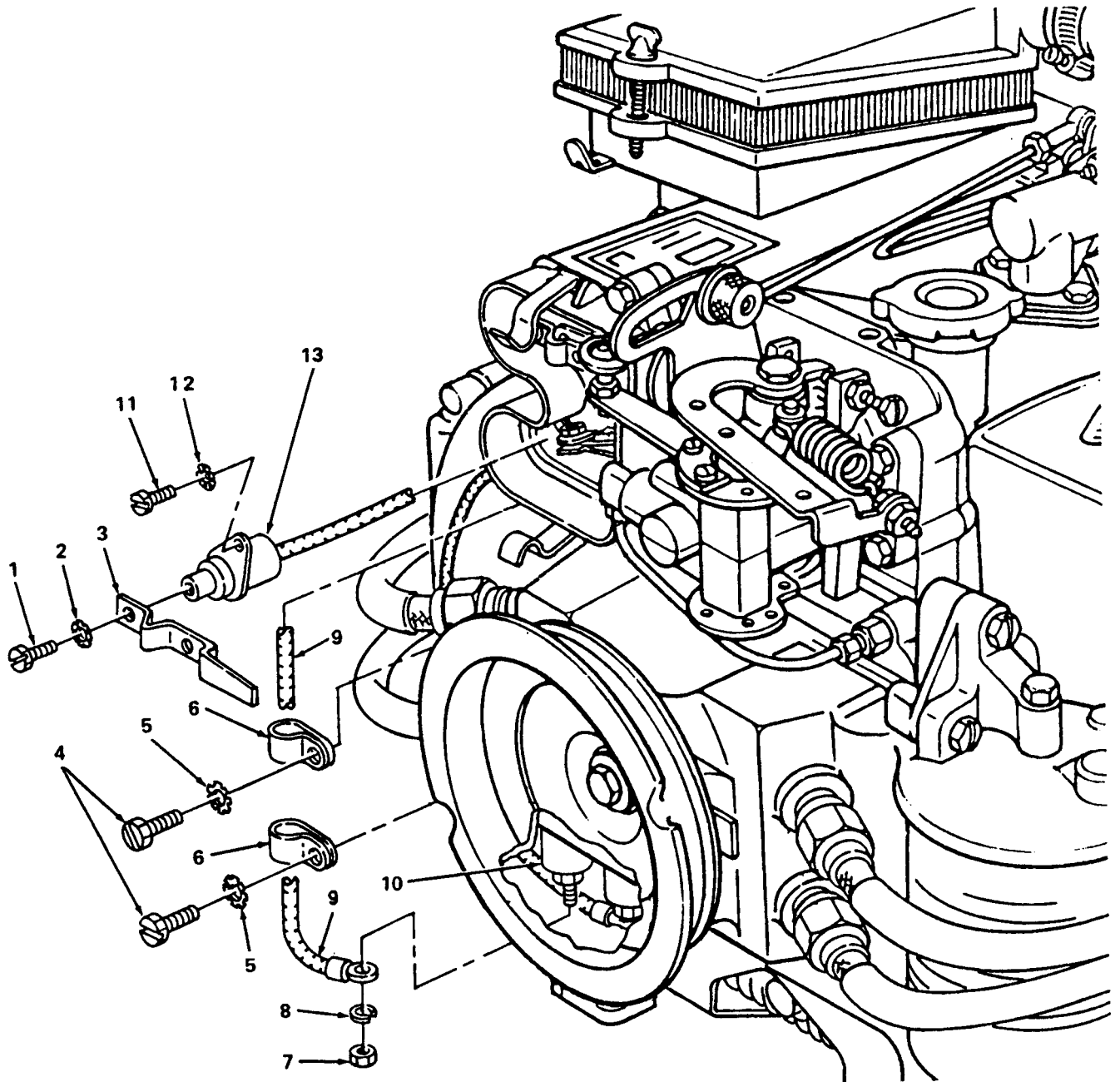

4868-049

Figure 4-45. Condenser, Replacement.

4-47. **Coil Cover.**

- This task covers:
- a. Removal (breaker point ignition)
 - b. Inspection (breaker point ignition)
 - c. Installation (breaker point ignition)
 - d. Removal (breakerless ignition)
 - e. Installation (breakerless ignition)

INITIAL SETUP

<i>Tools</i>	<i>Equipment Condition</i>
General Mechanic's Tool Kit (Item 1, Appendix B)	Breaker point cover removed on engines equipped with breakerless ignition (para. 4-44).
<i>Materials/Parts</i>	Starter rope pulley removed (para. 4-43).
Gasket, Coil Cover Mounting (NSN 5330-00-867-8795)	

a. Removal (Breaker Point Ignition). (figure 4-46)

- (1) Loosen connector nut (1) and tag and remove high tension cable (2).
- (2) Repeat step 1 for remaining high tension cables.
- (3) Remove nut (3) and washer (4) and tag and remove electrical lead (5) from noise suppression filter (6).
- (4) Repeat step 3 for remaining noise suppression filter.
- (5) Remove screw (7) and washer (8) securing cable clamp (9) and move out of way.
- (6) Repeat step 5 for remaining cable clamp.
- (7) Remove two screws (10), washers (11), securing coil cover (12), and gasket (13).
- (8) Remove nut (14) and washer (15) securing coil lead (16) to noise suppression filter (6) and tag and remove lead.
- (9) Repeat step 8 for remaining noise suppression filter, remove coil cover (12), and gasket (13).

b. Inspection. (figure 4-46)

Inspect coil cover (12) for cracks, inspect gasket (13) for tears, and replace if damaged.

c. Installation (Breaker Point Ignition). (figure 4-46)

- (1) Connect coil lead (16) as tagged to noise suppression filter (6) and secure with nut (14) and washer (15).
- (2) Repeat step 1 for remaining noise suppression filter.
- (3) Install coil cover (12) and new gasket (13) and secure with two screws (10) and washers (11).

- (4) Install cable clamp (9) and secure with screw (7) and washer (8).
- (5) Repeat step 4 for remaining cable clamp.
- (6) Connect electrical lead (5) to noise suppression filter (6) and secure with nut (3) and washer (4).
- (7) Repeat step (6) for remaining noise suppression filter.
- (8) Install high tension cable (2), as tagged, and tighten connector nut(1).
- (9) Repeat step (6) for remaining high tension cables.

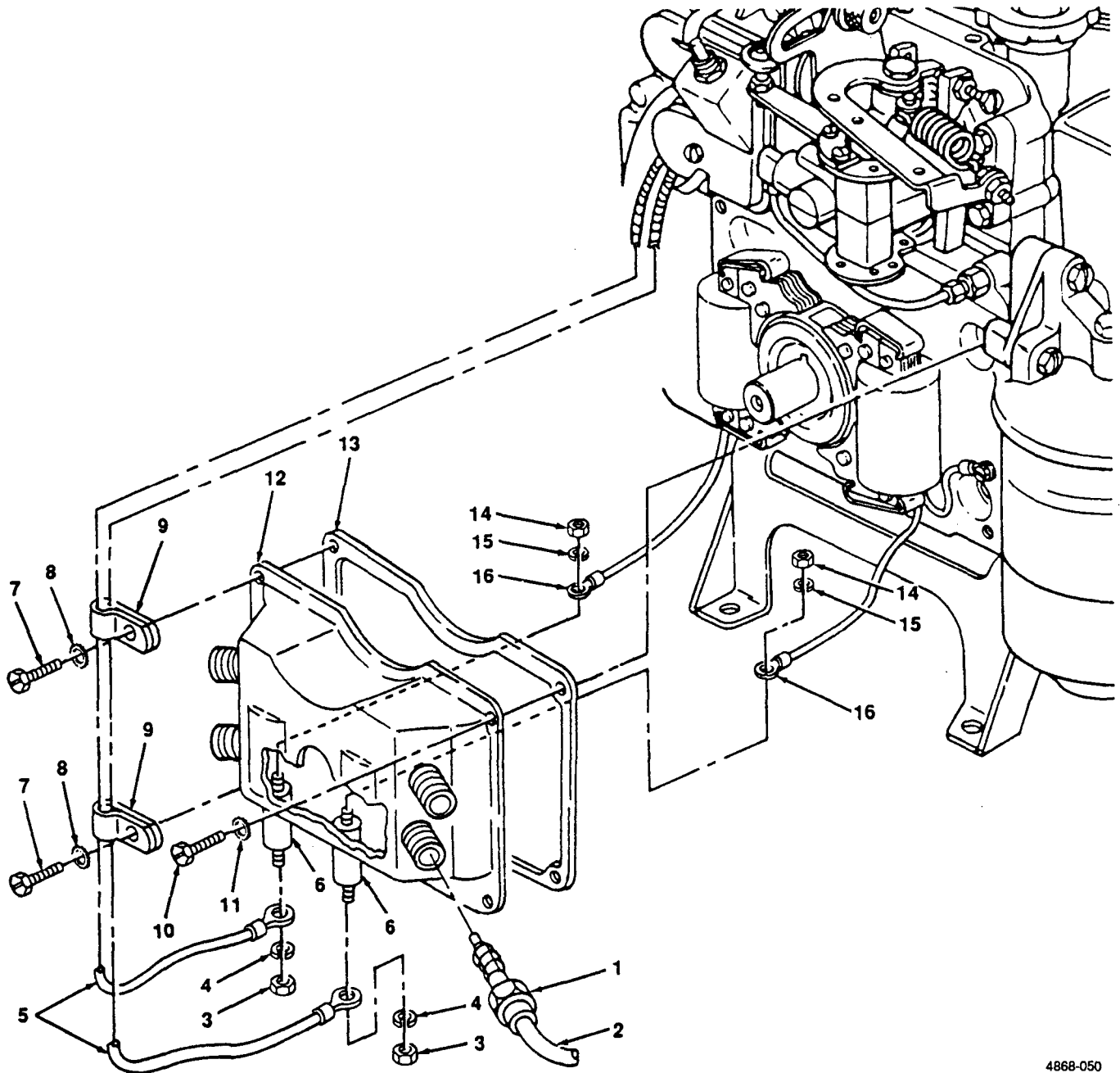

4868-050

Figure 4-46. Coil Cover (Breaker Point Ignition), Removal and Installation.

4-47. **Coil Cover (cont).**

d. Removal(BreakerlessIgnition) . (figure 4-47)

- (1) Remove screw (1) and washer (2) securing loop clamp (3), and remove loop clamp (3) from lead (4).
- (2) Disconnect two low voltage cables (5) and (6) from junction box (7).
- (3) Remove four screws (8) and washers (9) securing coil cover (10) and open coil cover.
- (4) Tag and disconnect coil leads (11) from coil cover (10) and remove coil cover (10) and gasket (12).
- (5) Inspect coil cover (10) and replace if cracked or otherwise damaged.
- (6) Inspect gasket (12) and replace if torn or otherwise damaged.

e. Installation (Breakerless Ignition). (figure 4-47)

- (1) Connect coil leads (11), as tagged to coil cover (10).
- (2) Ensure gasket surfaces are clean and free of old gasket.
- (3) Install coil cover (10) and new gasket(12) and secure with four screws (8) and washers (9).
- (4) Connect low voltage cables (5) and (6) to junction box (7).
- (5) Install lead (4) and secure with loop clamp (3), screw (1), and washer (2).

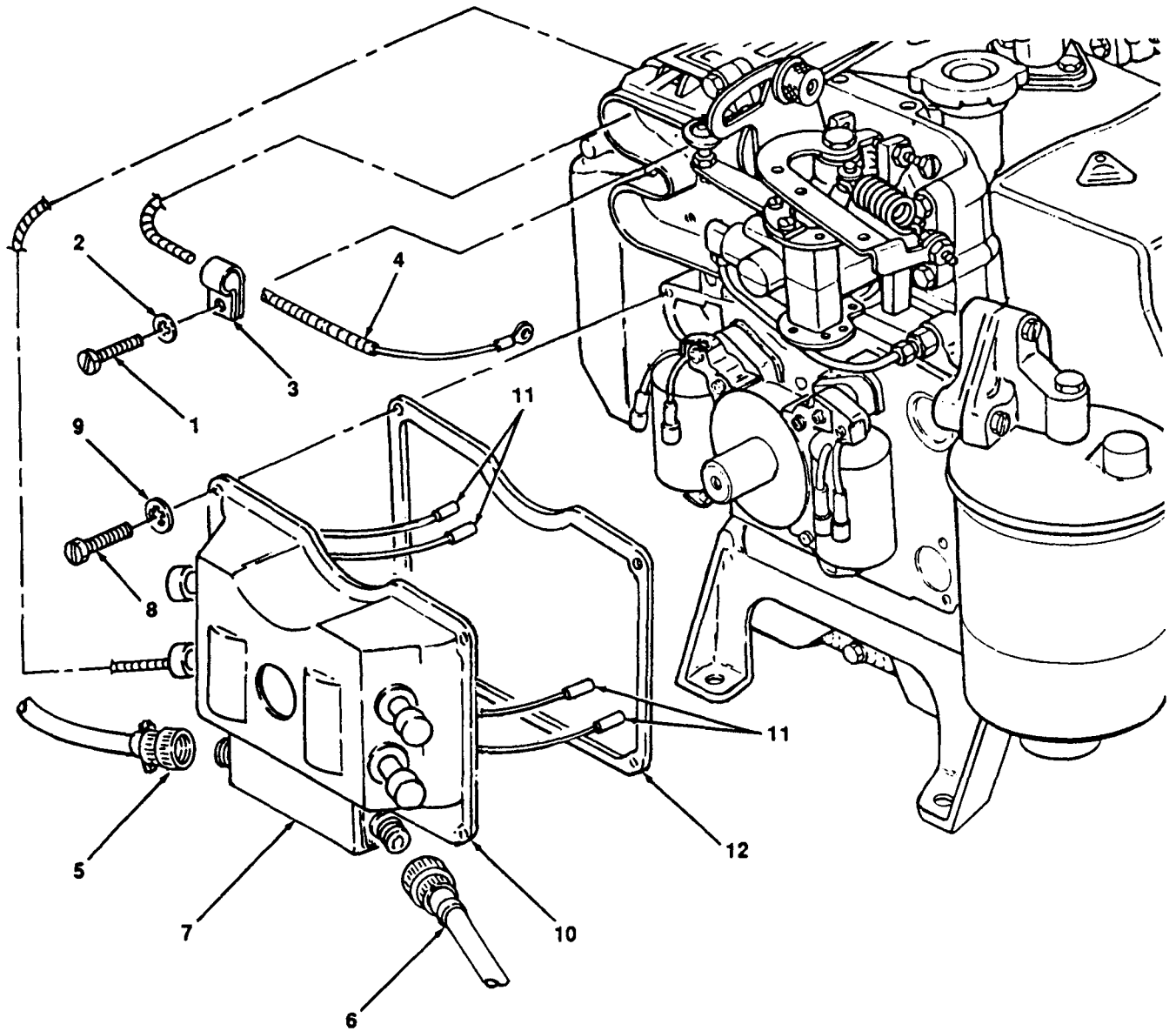

4868-052

Figure 4-47. Coil Cover (Breakerless Ignition), Removal and Installation.

4-48. Noise Suppression Filters (Breaker Point Ignition).

This task covers: a. Removal b. Test c. Installation

INITIAL SETUP

Tools

Equipment Condition

General Mechanic's Tool Kit (Item 1, Appendix B)
Multimeter (NSN 6625-01-139-2512) (Item 2,
Appendix B)

Coil cover removed (para. 4-47).

a. Removal. (figure 4-48)

- (1) Remove nut (1) and washer (2), and remove noise suppression filter (3).
- (2) Remove nut (4) and washer (5), and remove noise suppression filter (6).

b. Test.

- (1) Test noise suppression filters for leaks, shorts, or open circuits.
- (2) Replace a defective or otherwise damaged filter.

c. Installation. (figure 4-48)

- (1) Install noise suppression filter (6) and secure with nut (4) and washer (5).
- (2) Install noise suppression filter (3) and secure with nut (1) and washer (2).

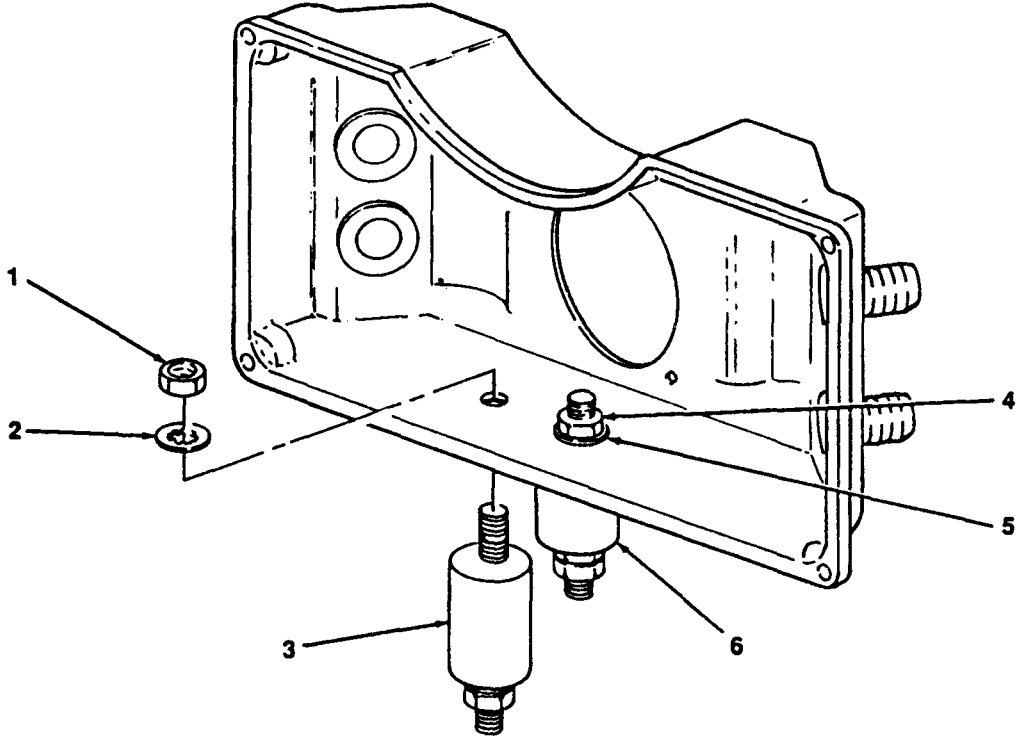

4868-053

Figure 4-48. Noise Suppression Filters, Removal and Installation.

4-49. Breaker Points (Breaker Point Ignition).

This task covers: a. Adjustment b. Removal c. Inspection d. Installation

INITIAL SETUP

Tools

General Mechanic's Tool Kit (Item 1, Appendix B)

Equipment Condition

Breaker point cover removed (para. 4-44).

Materials/Pats

Oil, Engine (NSN 9150-01-152-4117) Item 3,
Appendix D)

a. Adjustment. (figure 4-49)

- (1) Rotate the starter rope pulley (1) until the cam follower (2) is on the highest point of the ignition cam (3).
- (2) Loosen screw (4) and adjust point gap to 0.016-0.020 in. (0.406-0.508cm).
- (3) Tighten screw (4), and recheck gap, repeat step (2) if gap is incorrect.
- (4) Repeat steps 1 through 3 for upper breaker points (5).
- (5) Lubricate cam wick (6) sparingly with clean engine oil.

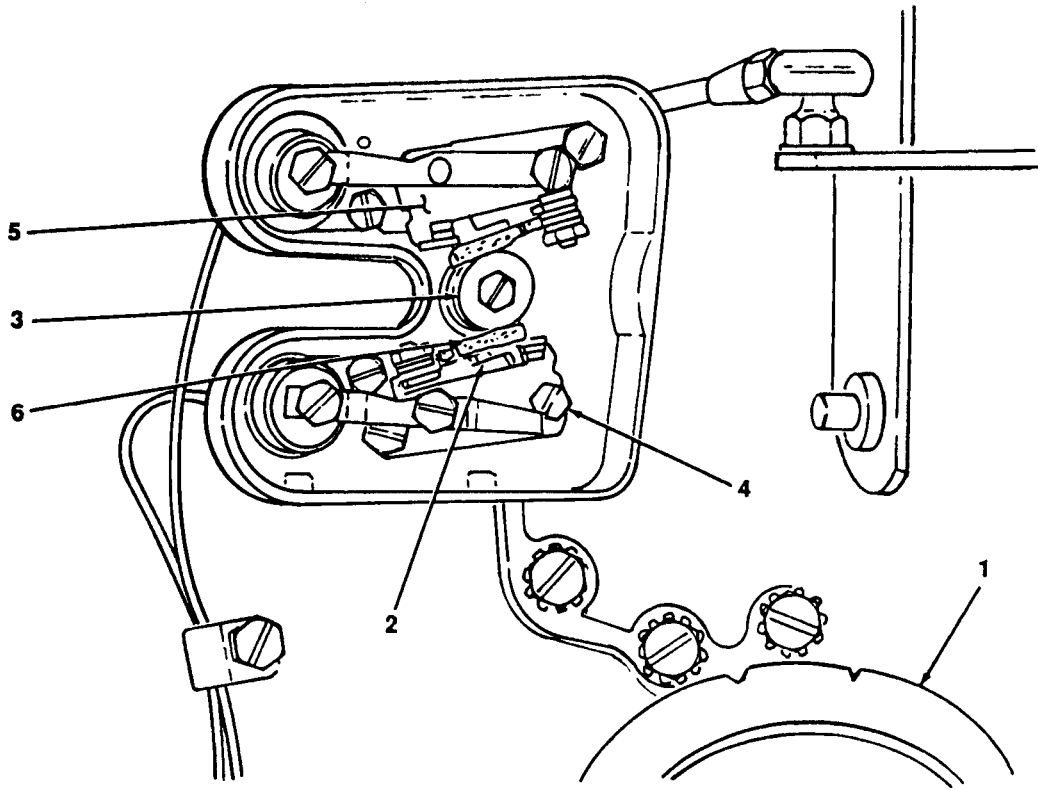

4868-054

Figure 4-49. Breaker Points, Adjustment.

4-49. **Breaker Points (cont).**

NOTE

The removal and installation procedures are the same for both sets of breaker points.

b. Removal. (figure 4-50)

(1) Remove two screws (1) and washers (2) and remove connector bar (3).

(2) Remove two screws (4) and washers (5) and remove breaker points (6).

c. Inspection. (figure 4-50)

Inspect breaker points (6) and replace if cam follower (7) is cracked or otherwise damaged, contacts (8) are burned or pitted, or cam wick (9) is missing.

d. Installation. (figure 4-50)

NOTE

Do not tighten right hand screw of lower breaker points or left hand screw of upper breaker points, fully at this point.

Install breaker points (6) and secure with two screws (4) and washers (5) and adjust points.

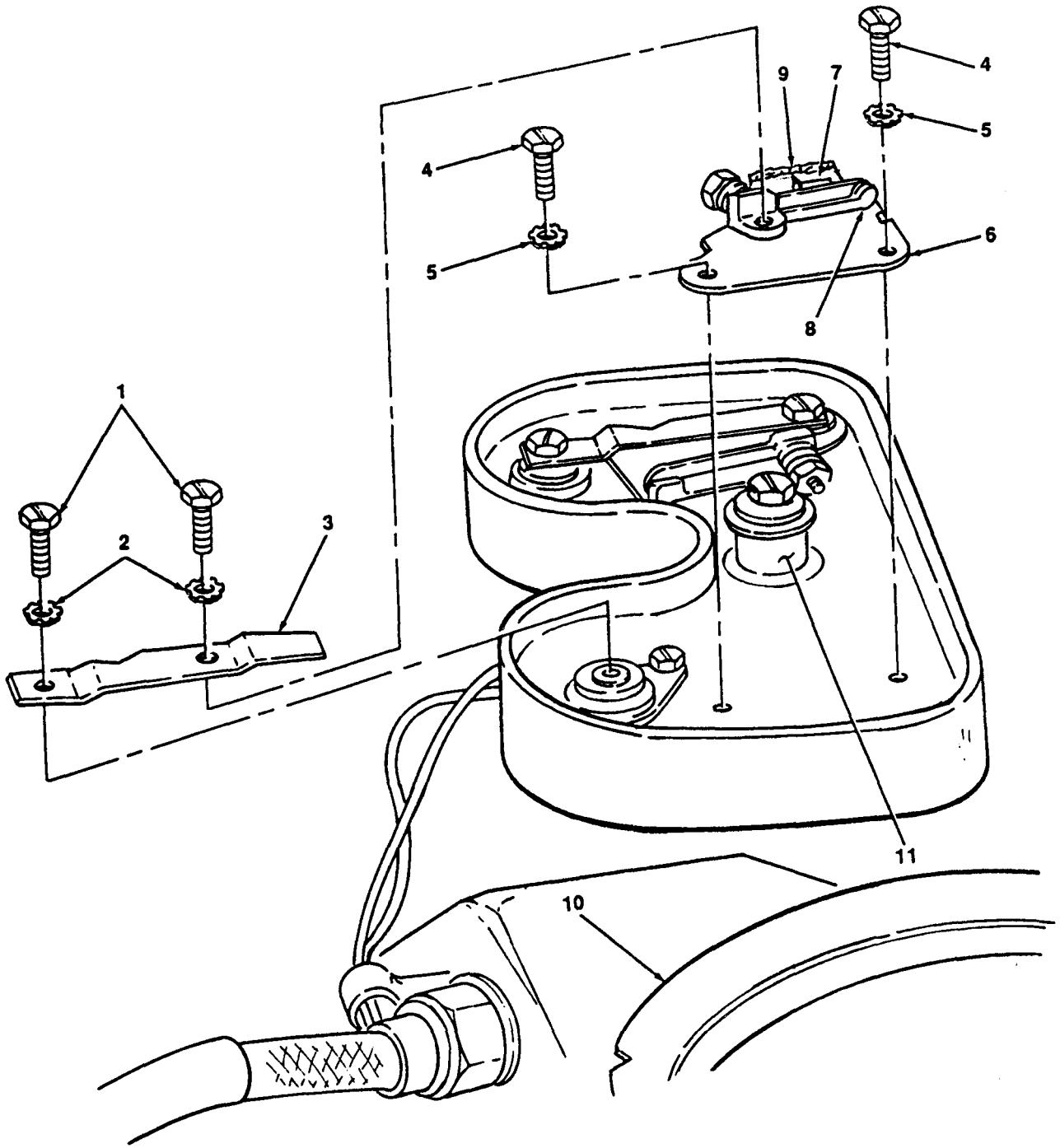

4868-055

Figure 4-50. Breaker Points, Removal and Installation.

4-50. Ignition Timing (Breaker Point Ignition).

This task covers: Adjustment

INITIAL SETUP

Tools

General Mechanic's Tool Kit (Item 1, Appendix B)

Equipment Condition

Number one cylinder rocker cover removed (para. 4-32).
Breaker point cover removed (para. 4-44).

Adjustment. (figure 4-51)

- (1) Rotate starter rope pulley (1) until both rockers (2) open and close, and stop when top dead center (TDC) mark (3) aligns with timing mark (4).
- (2) Observe lower contact points cam follower (5), it should be on the highest point of ignition cam (6). If not, loosen screw (7) and rotate ignition cam (6) until cam follower (5) is on highest point of ignition cam (6), and tighten screw (7).

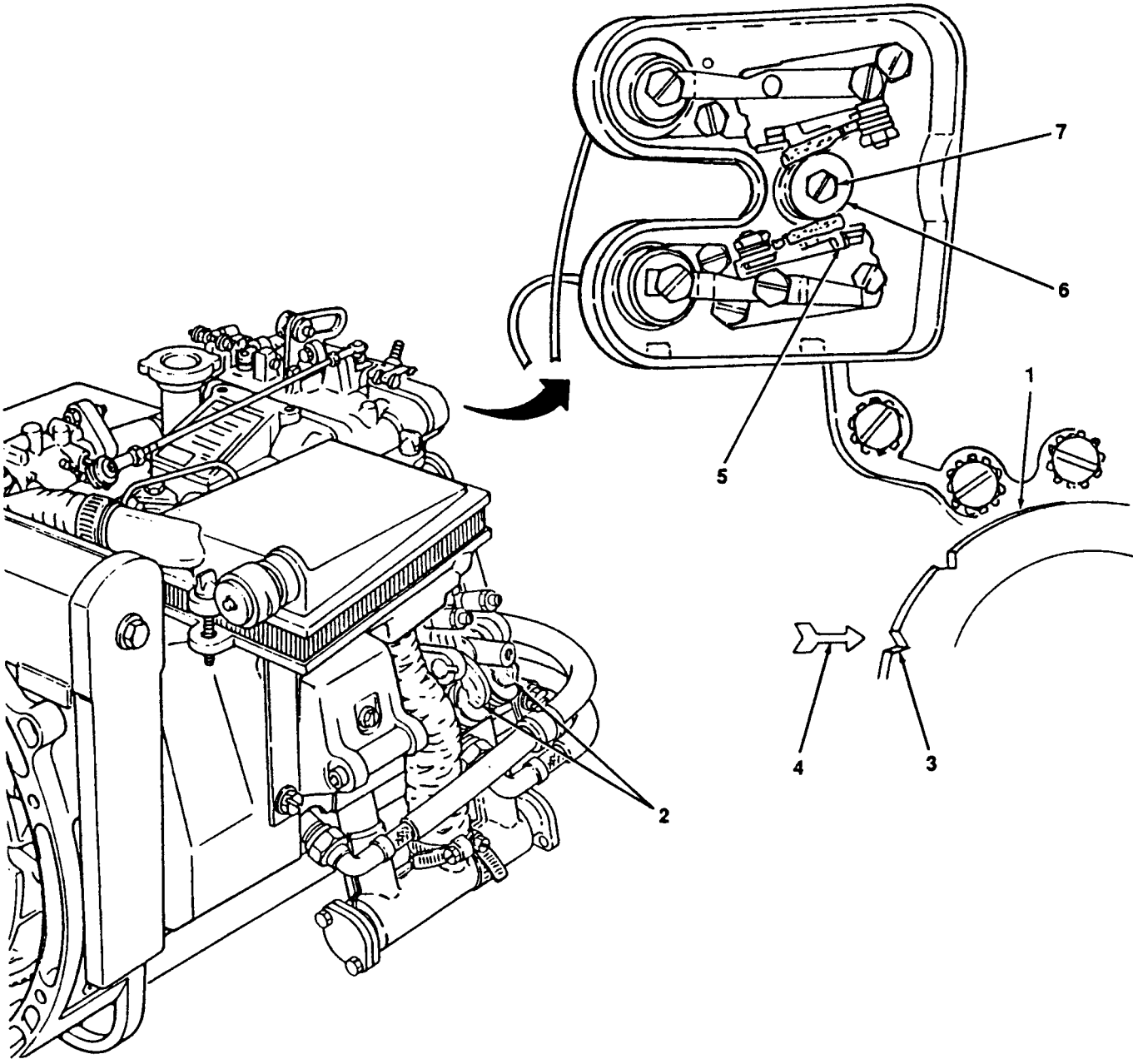

4868-089

Figure 4-51. Ignition Timing, Adjustment

Section VI. PREPARATION FOR SHIPMENT OR STORAGE

Paragraph		Page
4-51	General	4-106
4-52	Short Term and Intermediate Storage Procedures	4-106

4-51. **General.** This section contains procedures to place the engine into either short term or intermediate storage.

NOTE

The procedures for placing the engine into either short term or intermediate storage are the same.

4-52. **Short Term and Intermediate Storage Procedures.**

- a. Perform operator Before and After and Unit PMCS.
- b. Remove end item fuel supply.
- c. Drain fuel system.
- d. Drain engine oil.
- e. Secure fuel filter and starter rope to engine.

4-53. **Administrative Storage.**

- a. Placement of equipment in administrative storage should be for short periods of time when a shortage of maintenance effort exists. Items should be in mission readiness within 24 hours or within the time factors as determined by the directing authority. During the storage period appropriate maintenance records will be kept.
- b. Before placing equipment in administrative storage, current maintenance services and equipment serviceable criteria (ESC) evaluations should be corrected, and all modification work orders (MWO'S) should be applied.
- c. Storage site selection. Inside storage is preferred for items selected for administrative storage. If inside storage is not available, trucks, vans, conex containers and other containers maybe used.

CHAPTER 5

DIRECT SUPPORT MAINTENANCE INSTRUCTIONS

	Page
OVERVIEW	5-1
Section I. Repair Parts; Special Tools; Test, Measurement, Diagnostic Equipment (TMDE); and Support Equipment	5-1
Section II. Direct Support Troubleshooting	5-1
Section III. Direct Support Maintenance Procedures	5-5

OVERVIEW

This chapter contains information for troubleshooting and maintenance of the engine by Direct Support Maintenance personnel.

Section I. REPAIR PARTS; SPECIAL TOOLS; TEST, MEASUREMENT, DIAGNOSTIC EQUIPMENT (TMDE); AND SUPPORT EQUIPMENT

Paragraph	Page
5-1 Common Tools and Test Equipment	5-1
5-2 Special Tools, TMDE, and Support Equipment	5-1
5-3 Repair Parts	5-1

5-1. Common Tools and Equipment. For authorized common tools and equipment, refer to the Modified Table of Organization and Equipment (MTOE) applicable to your unit.

5-2. Special Tools, TMDE, and Support Equipment. For a listing of special tools, TMDE, and support equipment authorized for use on this equipment, refer to the Repair Parts and Special Tools List, **TM 9-2805-262-24P**, and the Maintenance Allocation Chart (MAC), appendix B of this manual.

5-3. Repair Parts. Repair parts are listed and illustrated in the Repair Parts and Special Tools List for 6 hp Military Standard Engine, TM 9-2805-262-24P.

Section II. DIRECT SUPPORT TROUBLESHOOTING

Paragraph	Page
5-4 General	5-1
5-5 Direct Support Troubleshooting Procedures	5-2

5-4. General. This section contains troubleshooting procedures to determine the probable cause of observed equipment malfunctions. Test or inspections are provided to isolate the faulty component and corrective actions are provided to eliminate the malfunction.

5-5. Direct Support Troubleshooting Procedures. Table 5-1 lists the common malfunctions that may be found during operation. Refer to symptom index to locate the troubleshooting procedures for the malfunction. This manual cannot list all malfunctions that may occur, nor all test or inspections and corrective actions. If a malfunction is not corrected by listed corrective actions, notify your supervisor.

SYMPTOM INDEX

Symptom	Page
Engine will not start	5-2
Engine misses or runs erratically	5-2
Engine oil consumption excessive	5-3
Engine runs excessively noisy	5-3
Engine will not start or runs erratically (model 14A032-3, -4)	5-3

Table 5-1. Direct Support Troubleshooting Procedures.

Malfunction
 Test or Inspection
 Corrective Action

1. ENGINE FAILS TO START.

Step 1. Measure breaker point ignition coil primary windings resistance between noise suppression filter and engine ground and compare reading with manufacturer's specification.

Step 2. Remove high tension cable from spark plug and measure breather point ignition coil secondary windings resistance between spring end of cable and engine ground. Compare measured reading with manufacturer's specification.

Replace a defective coil (para. 5-17).

Manufacturer	Primary windings	Secondary windings
Bendix Corp.	.512 ± .050 ohms	3,300 ± 400 ohms
Colt Industries	.370 ± .025 ohms	8,500 ± 700 ohms
Motor Parts. Inc.	.370 ± .025 ohms	8,500 ± 700 ohms

Step 3. Inspect rotating magnet for corrosion.

Replace rotating magnet if corroded or otherwise damaged (para. 5-11).

2. ENGINE MISSES OR RUNS ERRATICALLY.

Step 1. Check valve adjustment.

Adjust valves as needed (para. 5-8).

Table 5-1. Direct Support Troubleshooting Procedures (cont).

Malfunction

Test or Inspection

Corrective Action

Step 2. inspect and test coil.

Replace defective coil (para.5-17).

Step 3. Check for cracked cylinder head and or leaky gasket.

Replace cracked or otherwise damaged cylinder head (para.5-7).

Step 4. Check intake and exhaust valve for damage or excessive wear.

Replace damaged valve (para.5-10).

Step 5. Check piston and piston rings for damage or excessive wear.

Replace damaged or worn piston and rings (para. 5-22).

3. ENGINE OIL CONSUMPTION EXCESSIVE.

Check piston and piston rings for wear.

Replace worn or damaged piston and piston rings (para.5-22).

4. ENGINE RUNS EXCESSIVELY NOISY.

Step 1. Check valve mechanism for bent or otherwise damaged components.

Replace worn or damaged components (para.5-7).

Step 2. Check piston and connecting rod for wear.

Replace a worn piston or connecting rod (para.5-22).

5. ENGINE WILL NOT START OR RUNS ERRATICALLY MODEL 4A032-3, -4

NOTE

The following procedures can be performed with either a digital or analog multimeter refer to figure 5-26 for wiring diagram of electronic ignition system.

Step 1. Check low voltage and high tension cable ends for looseness.

Tighten any loose connections.

Table 5-1. Direct Support Troubleshooting Procedures (cont).

Malfunction
Test or Inspection
Corrective Action

NOTE

Repeat step 2 for all four high tension cables.

Step 2. Remove high tension cable from spark plug. Ground cable and hold spring approximately 1/4 in. (6 cm.) from engine. Pull start engine and check for spark.

If spark is present remove and inspect spark plug (para. 4-28),

NOTE

Perform steps 3 through 9 for both right and left hand ignition control units.

Step 3. Remove ignition control unit cover and check for moisture or foreign material.

If moisture is present clean and dry terminals and connections and repeat step 2.

Step 4. Check low voltage cable end to end continuity.

If continuity is not present in all three lines replace low voltage cable (para. 5-16).

Step 5. Remove wiring from no.1 terminal on ignition control unit module. Measure resistance between terminal no.1 and ground.

If reading is less than 1 Megohm replace ignition module (para.5-14).

Step 6. Remove wiring from terminals no.5 and no.6 and check resistance. Meter should show an initial deflection then a reading of 1 Megohm.

If final reading is not 1 Megohm then replace ignition control unit ignition module (para.5-14).

Step 7. Check transformer resistance between white and brown wires.

If resistance is more than 1 ohm replace transformer (para.5-13).

Step 8. Check transformer resistance between white wire and spring on end of high voltage cable.

If resistance is not between 1400 and 2500 ohms, replace transformer (para.5-13).

Table 5-1. Direct Support Troubleshooting Procedures (cont).

Malfunction
 Test or Inspection
 Corrective Action

NOTE

The right hand coil is for the left hand ignition control unit, and the left hand coil is for the right hand coil.

Step 9. Check coil resistance between pins E and D of low voltage connector on junction box

If resistance is not between 289 and 329 ohms replace coil (para. 5-17).

Step 10. Perform junction box continuity between pins of junction box connector and ground

If continuity is present between pins and ground, replace junction box (para. 5-1 5)

Section II. DIRECT SUPPORT MAINTENANCE PROCEDURE

Paragraph		Page
5-6	General.....	5-6
5-7	Cylinder Head Assembly	5-6
5-8	Valves.....	5-14
5-9	Rockers	5-16
5-10	Intake and Exhaust Valves.....	5-18
5-11	Rotating Magnet	5-20
5-12	Ignition Control Unit (Breakerless Ignition).....	5-22
5-13	Transformer (Breakerless Ignition)	5-24
5-14	Ignition Module (Breakerless Ignition).....	5-26
5-15	Junction Box (Breakerless Ignition).....	5-28
5-16	Low Voltage Cable (Breakerless Ignition)	5-30
5-17	Coil	5-32
5-18	Oil Pump Cover	5-34
5-19	Oil Pump Gears and Wear Plate	5-36
5-20	Oil Pan and Screen	5-38
5-21	Drain Tube.....	5-40
5-22	Piston and Connecting Rod Assembly	5-42
5-23	Flywheel	5-48
5-24	Flywheel Housing and Protective Screen.....	5-50
5-25	Oil Pressure Regulation Valve Assembly	5-52
5-26	Oil Filler Tube and Gage	5-54
5-27	Crankcase Oil Seal.....	5-56

- (10) Compare readings from each cylinder. The readings should be within 25 psi (173 Kpas) of each other. If not, further engine inspection is required.

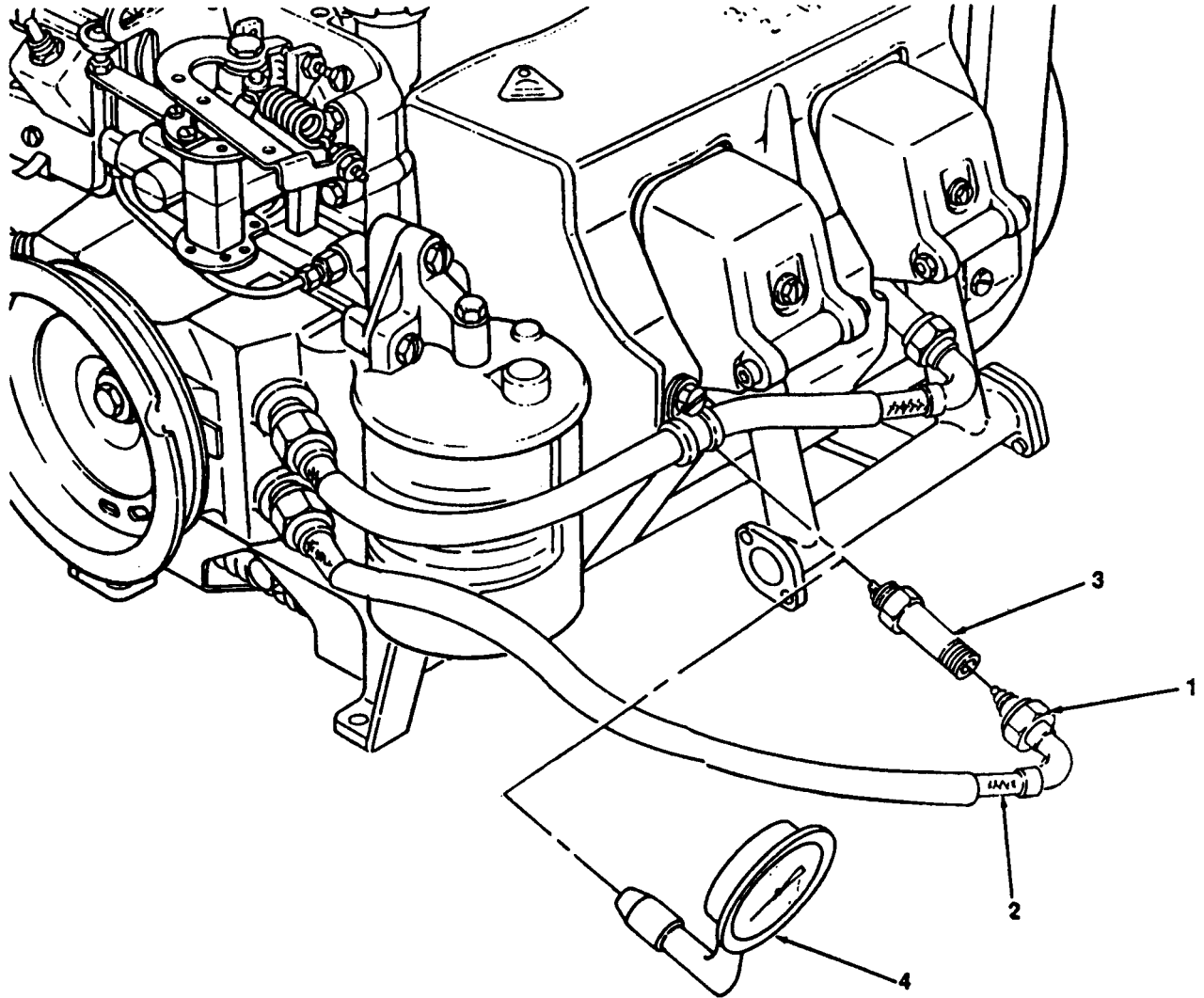

4868-056

Figure 5-1. Compression Test.

5-7. Cylinder Head Assembly (cont).

b. Removal. (figure 5-2)

- (1) Loosen lock nut (1) and loosen adjuster screw (2) until rocker (3) is loose.
- (2) Repeat step 1 for remaining rocker.
- (3) Loosen fitting nut (4) on drain tube (5).
- (4) Loosen compression nut (6) and remove drain tube (5).
- (5) Remove four nuts (7), and washers (8), and remove cylinder head (9) and gasket (10).
- (6) Remove pushrods (11), pushrod tubes (12) and preformed packing (13).
- (7) Repeat steps 1 thru 6 for remaining cylinder heads.

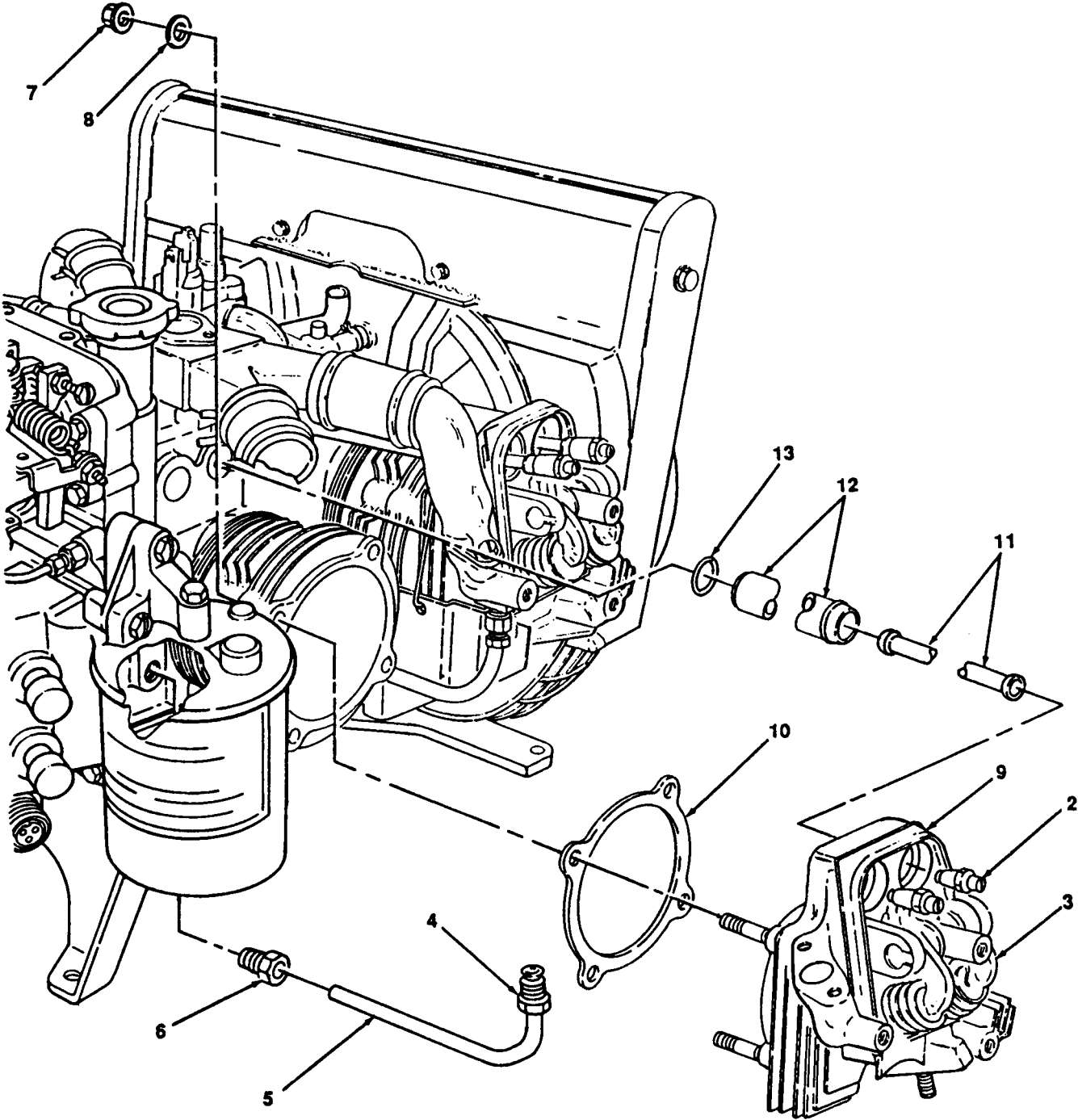

4868-057

Figure 5-2. Cylinder Head, Removal.

5-7. Cylinder Head Assembly (cont).

c. *Repair.* (figure 5-3)

- (1) Remove rocker shaft clip (1) and remove rocker shaft (2) and rocker (3).
- (2) Using valve spring compressor, compress spring (4), remove retainers (5), valve (6), roto cap (7), and spring (4).
- (3) Repeat step 2 for remaining valve.
- (4) Remove packing screws (8) and preformed packings (9).

WARNING

Drycleaning solvent PD-680 used to clean parts is potentially dangerous to personnel and property. Avoid repeated and prolonged skin contact. Do not use near open flame or excessive heat. Flash point of solvent is 100°F-1 38°F (38°C-60°C).

- (5) Clean all items, except preformed packings, in drycleaning solvent and dry thoroughly.
- (6) Inspect all items for excessive wear, and replace worn or otherwise damaged items. Refer to table 5-2 for wear limits.
- (7) Reseat valves in cylinder head to ensure proper sealing. Regrind valves as necessary. Refer to table 5-2.
- (8) Install valve (6), spring (4), and roto cap (7).
- (9) Using valve spring compressor, compress spring (4) and install retainers (5).
- (10) Repeat steps 8 and 9 for remaining valve.
- (11) Install preformed packing (9) and packing screws (8).
- (12) Install rocker (3), rocker shaft (2) and rocker clip(1).

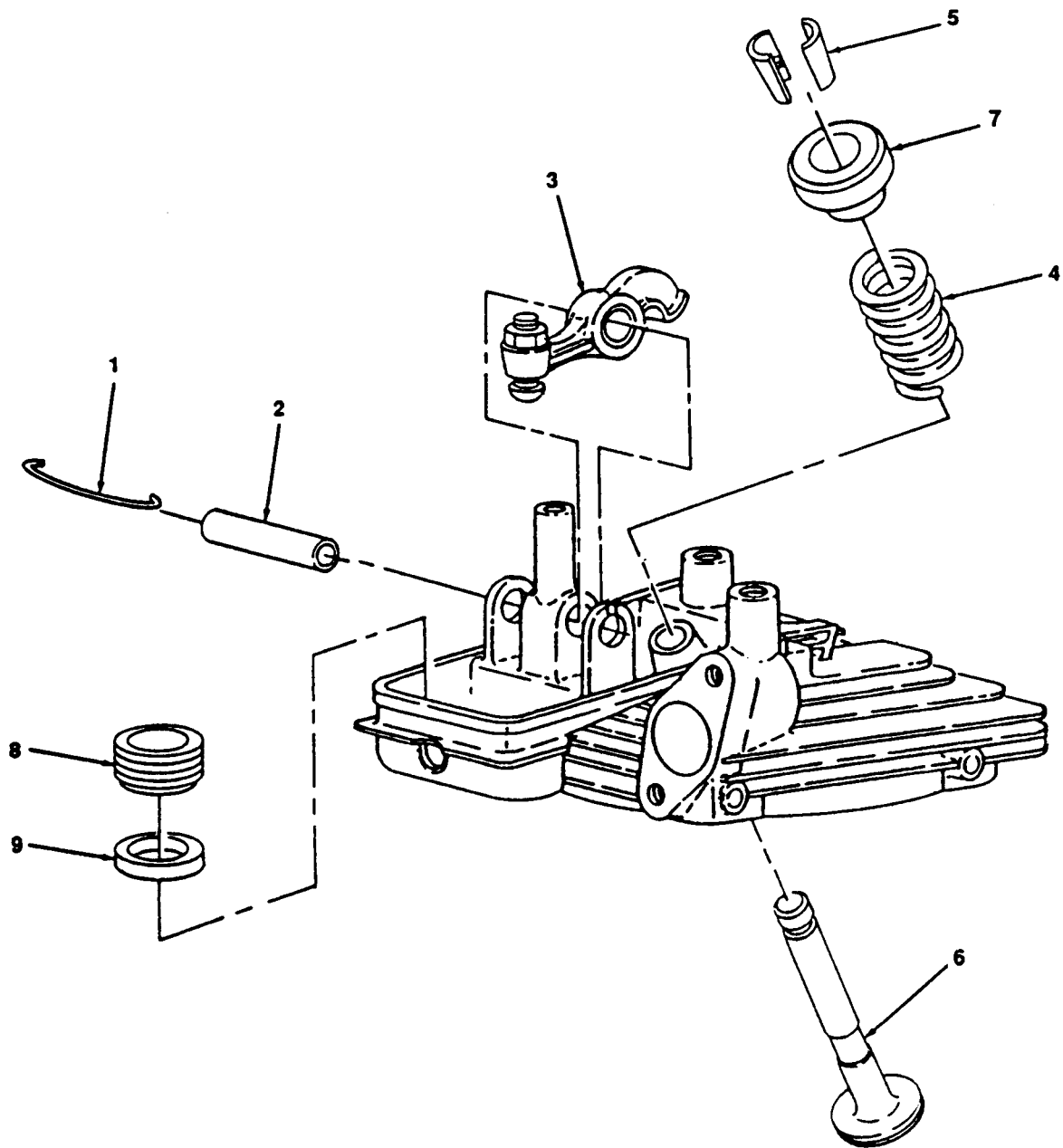

4868-058

Figure 5-3. Cylinder Head, Repair.

5-7. Cylinder Head Assembly (cont).

d. Installation. (figure 5-4).

- (1) Ensure all gasket surfaces are clean, and old gasket material is removed.
- (2) Install preformed packings (13), pushrod tubes (12), and push rods(11).
- (3) Install cylinder head (9) and gasket (10) and secure with four nuts (7) and washers (8). Toque nuts to 22-24 ft lb (47151-51437 gr cm).
- (4) Install drain tube (5) and finger tighten compression nut (6).
- (5) Connect drain tube (5) to cylinder head (9) and tighten coupling nut (4), and finish tightening compression nut (6).
- (6) Position rockers (3) on push rods(11) and tighten adjusting screws (2) until rockers are snug.
- (7) Adjust valves.
- (8) Repeat steps 1 thru 7 for remaining cylinder heads.

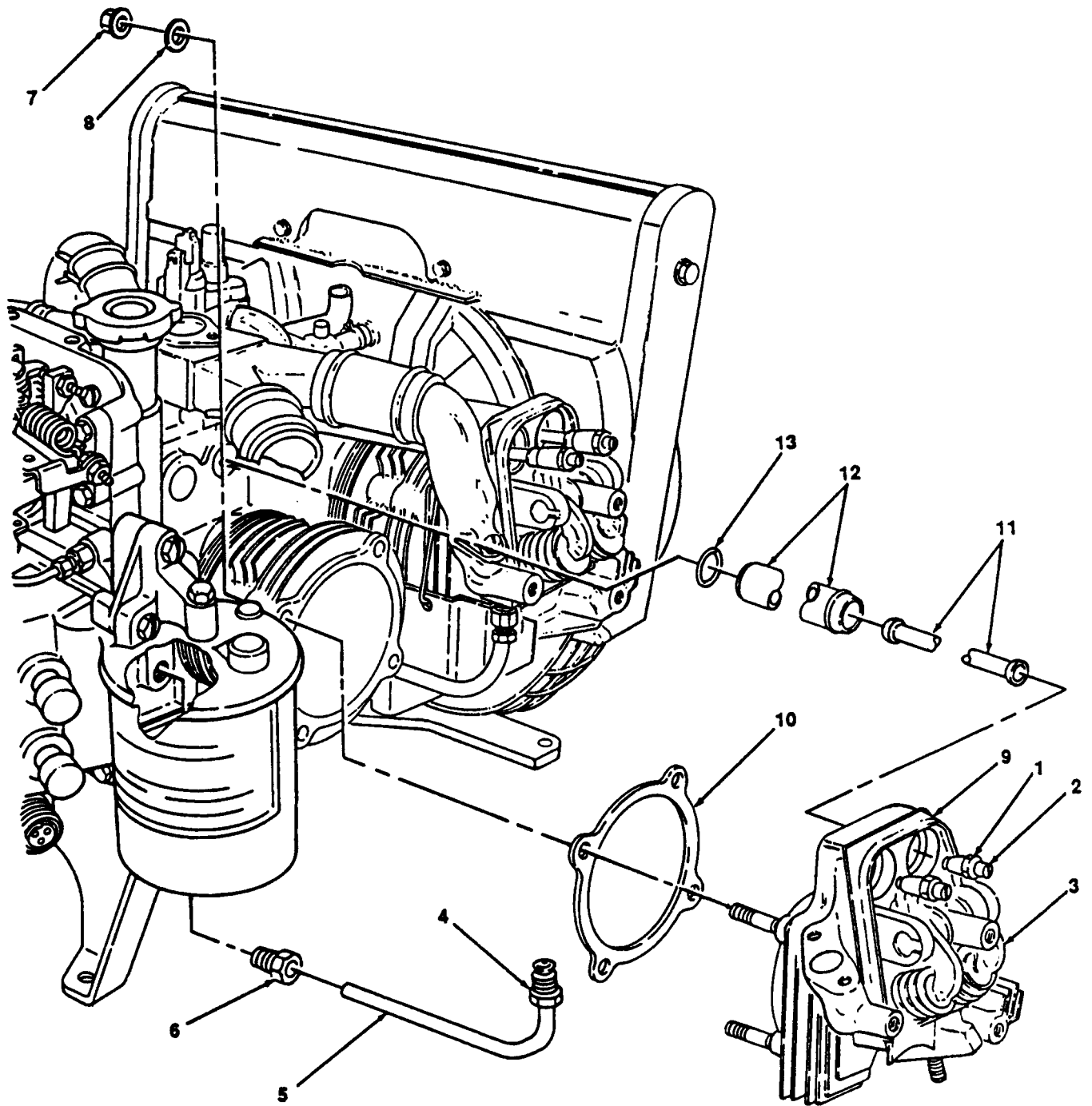

Figure 5-4. Cylinder Head, Installation.

5-8. Valves.

This task covers: Adjustment

INITIAL SETUP

<i>Tools</i>	<i>Equipment Condition</i>
General Mechanic's Tool Kit (Item 1, Appendix B)	Rocker box covers removed (para. 4-32).

Adjustment (figure 5-5)

- (1) Rotate starter rope pulley (1) until valve (2) closes.
- (2) Measure valve clearance. The clearance should be 0.007-0.009 in. (0.018-0.023cm).
- (3) Loosen lock nut (3), and turn adjusting screw (4) until desired clearance is obtained, and tighten locknut (3).
- (4) Recheck clearance and repeat step 3 if needed.
- (5) Repeat steps 1 thru 4 for remaining valves.

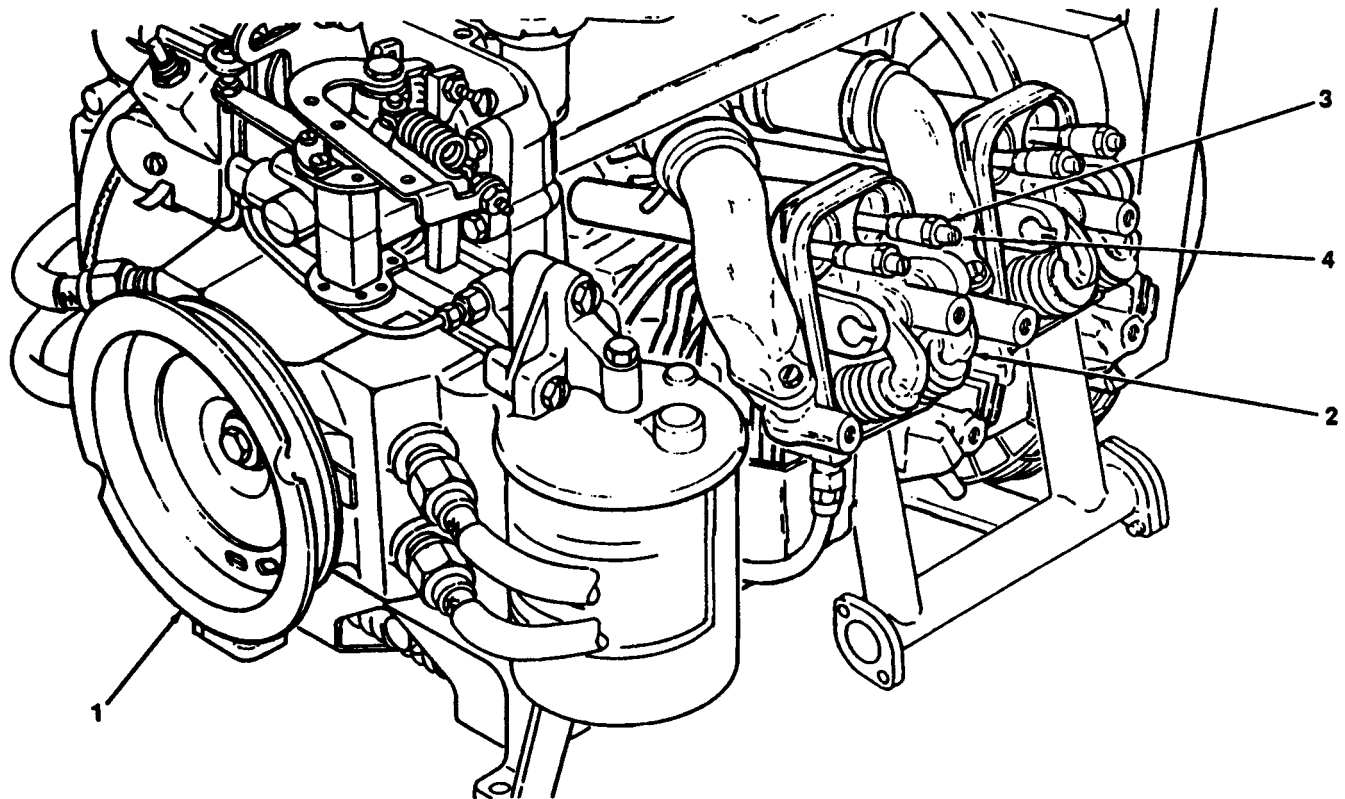

4868-060

Figure 5-5. Valves, Adjustment.

5-9. Rockers.

This task covers: a. Removal b. Inspection c. Installation

INITIAL SETUP

Tools

General Mechanic's Tool Kit (Item 1, Appendix B)

Equipment Condition

Rocker box cover removed (para. 4-32).

Materials/Patts

Rags, Wiping (Item 7, Appendix D)

Solvent, Drycleaning (Item 8, Appendix D)

a. Removal. (figure 5-6)

- (1) Loosen lock nut (1) and loosen adjusting screw (2) until rocker (3) is loose.
- (2) Repeat step 1 for remaining rocker (4).
- (3) Remove rocker clip (5) and rocker shaft (6), and remove rockers (3) and (4).

b. Inspection.

WARNING

Drycleaning solvent PD-680 used to clean parts is potentially dangerous to personnel and property. Avoid repeated and prolonged skin contact. Do not use near open flame or excessive heat. Flash point of solvent is 100°F-138°F (38°C-60°C).

- (1) Clean rockers with drycleaning solvent, and dry thoroughly.
- (2) Inspect rockers for wear, and replace a worn or otherwise damaged rocker. Refer to table 5-2 for wear limits.

c. Installation. (figure 5-6)

- (1) Install rockers (3) and (4) in cylinder head (7).
- (2) Install rocker shaft (6) and rocker clip (5).
- (3) Adjust valves (para. 5-8).

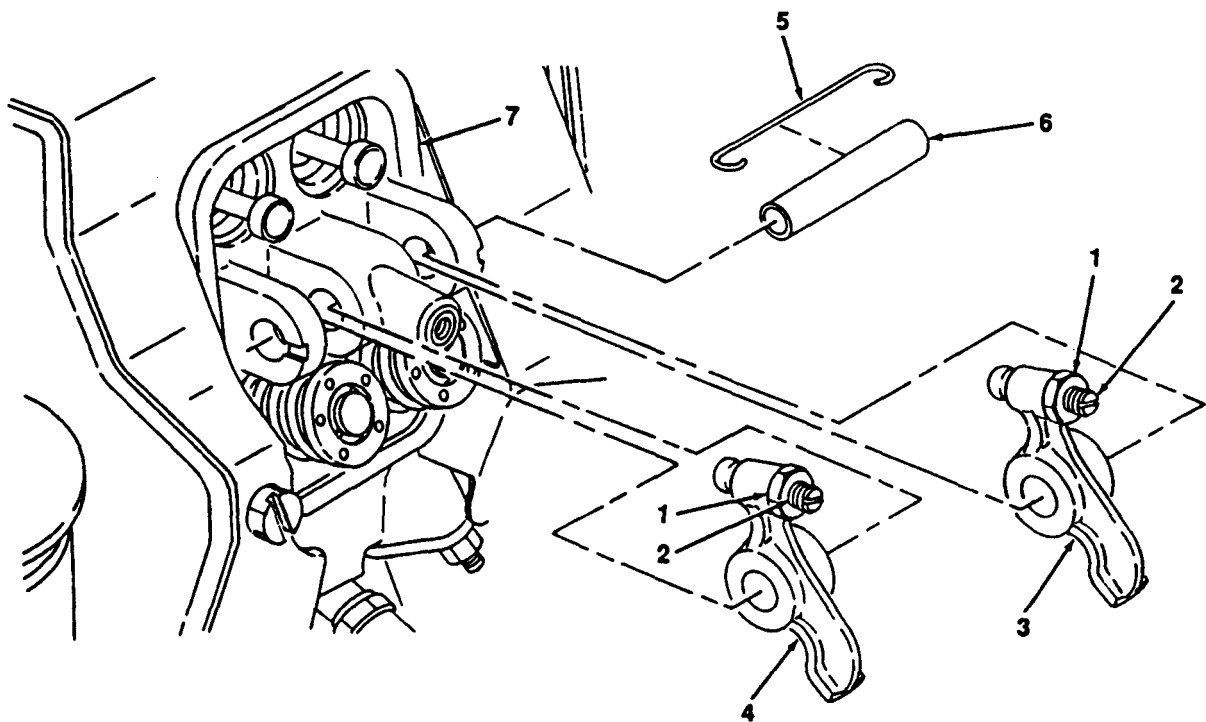

4868-061

Figure 5-6. Rockers, Removal and Installation.

5-10. Intake and Exhaust Valves.

This task covers: a. Removal b. Inspection c. Installation

INITIAL SETUP

Tools

General Mechanic's Tool Kit (Item 1, Appendix B)
Compressor, Valve Spring (NSN 5130-00-096-6677)
(Item 3, Appendix B)

Equipment Condition

Cylinder head removed (para. 5-7).

Materials/Pads

Rags, Wiping (Item 7, Appendix D)
Solvent, Drycleaning (Item 8, Appendix D)

a. Removal. (figure 5-7)

- (1) Remove rocker clip (1) and remove rocker shaft (2) and rocker (3).
- (2) Using suitable valve spring compressor, compress valve spring (4), and remove two retainers (5), valve (6), roto cap (7), and valve spring (4).
- (3) Repeat step 2 for remaining valve,

b. Inspection.

WARNING

Drycleaning solvent PD-680 used to clean parts is potentially dangerous to personnel and property. Avoid repeated and prolonged skin contact. Do not use near open flame or excessive heat. Flash point of solvent is 100°F-138°F (38°C-60°C).

- (1) Clean all items in drycleaning solvent, and dry thoroughly.
- (2) Inspect all items for excessive wear, and replace all items that are worn or otherwise damaged. Refer to table 5-2 for wear limits.

c. Installation. (figure 5-7)

- (1) Reseat valves in cylinder head to ensure proper seal. Regrind valves as necessary. Refer to table 5-2).
- (2) Install valve (6), valve spring (4) and roto cap (7).
- (3) Using suitable valve spring compressor, compress valve spring (4) and install two retainers (5).
- (4) Position rocker (3) in cylinder head (8).

- (5) Repeat steps 1 through 4 for remaining valve.
- (6) Install rocker shaft (2) and rocker clip (1).
- (7) Adjust valves (para. 5-8).

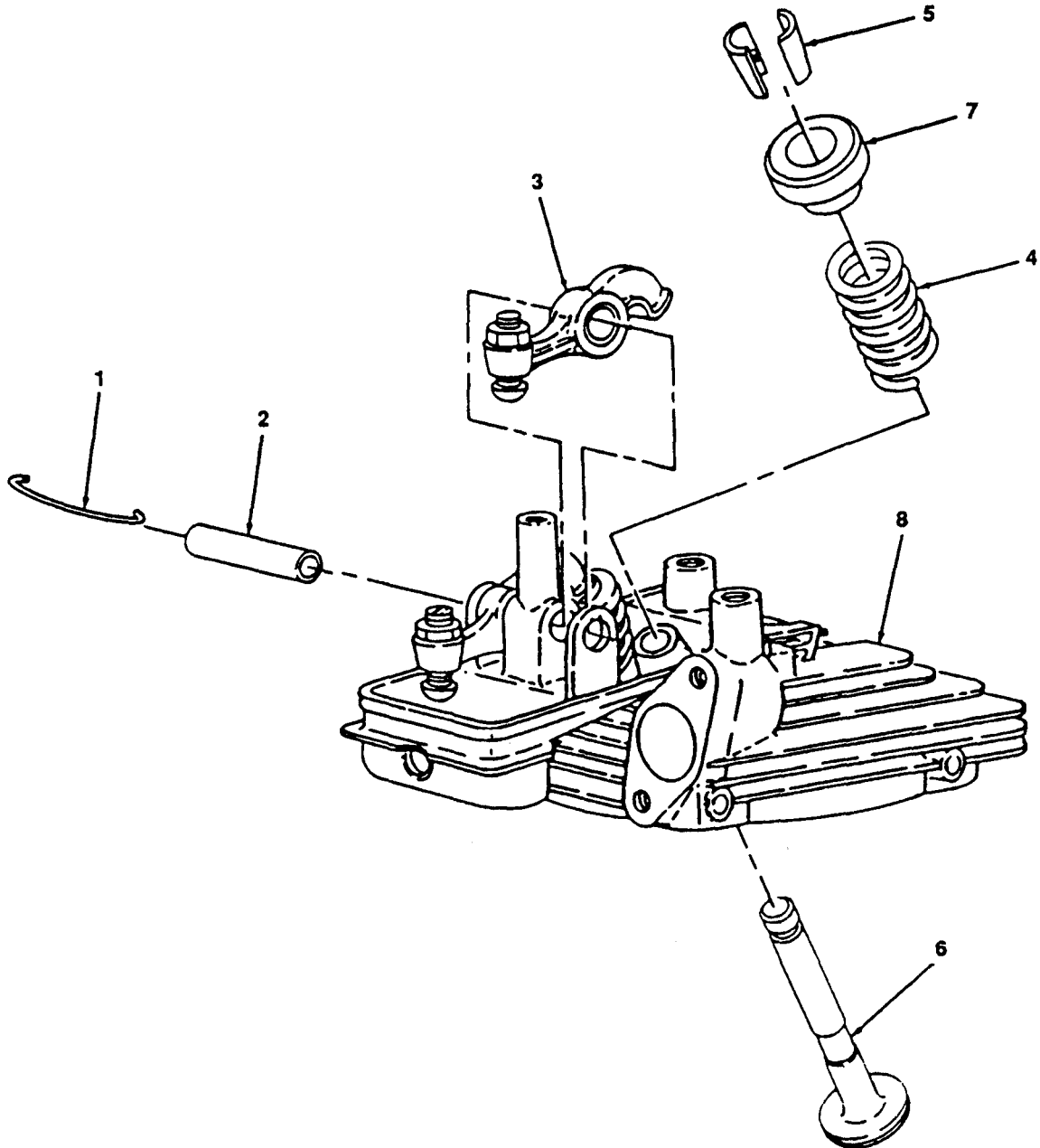

4868-062

Figure 5-7. Intake and Exhaust Valves, Removal and Installation.

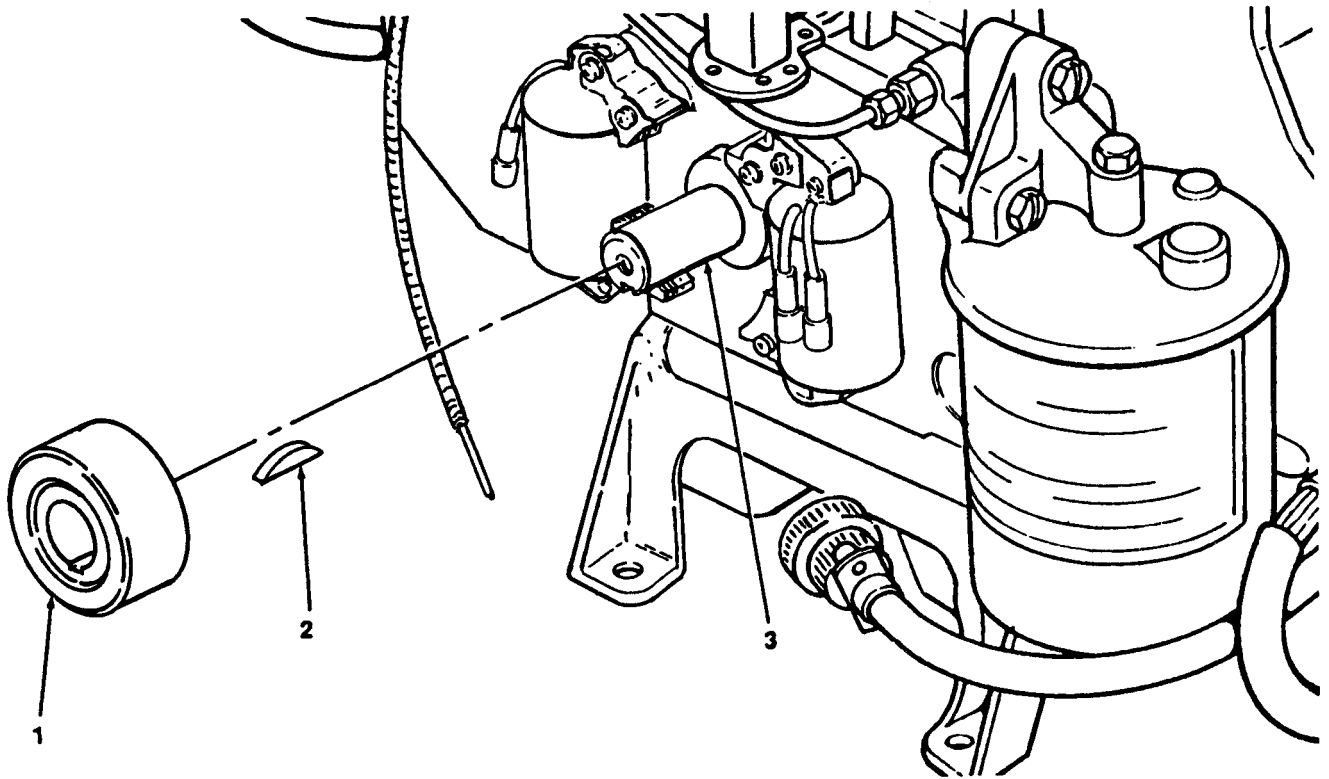

4868-063

Figure 5-8. Rotating Magnet, Removal and Installation.

5-12. Ignition Control unit (Breakerless Ignition).

This task covers: a. Removal b. Installation

INITIAL SETUP

<i>Tools</i>	<i>Equipment Condition</i>
General Mechanic's Tool Kit (Item 1, Appendix B)	Lower air cleaner duct when removing left hand electronic ignition control unit (para.4-15).

NOTE

The following procedures are the same for both the left and right hand sides.

a. Removal. (figure 5-9)

- (1) Loosen connector nut (1) and remove high tension cable (2).
- (2) Loosen connector nut (3) and remove high tension cable (4).
- (3) Disconnect low voltage cable (5) from junction box (6).
- (4) Remove two screws (7) and washers (8) and remove ignition control unit (9).

b. Installation. (figure 5-9)

- (1) Install ignition control unit (9) and secure with two screws (7) and washers (8).
- (2) Connect low voltage cable (5) to junction box (6).
- (3) Install high tension cable (4) and tighten connector nut (3).
- (4) Install high tension cable (2) and tighten connector nut (1).

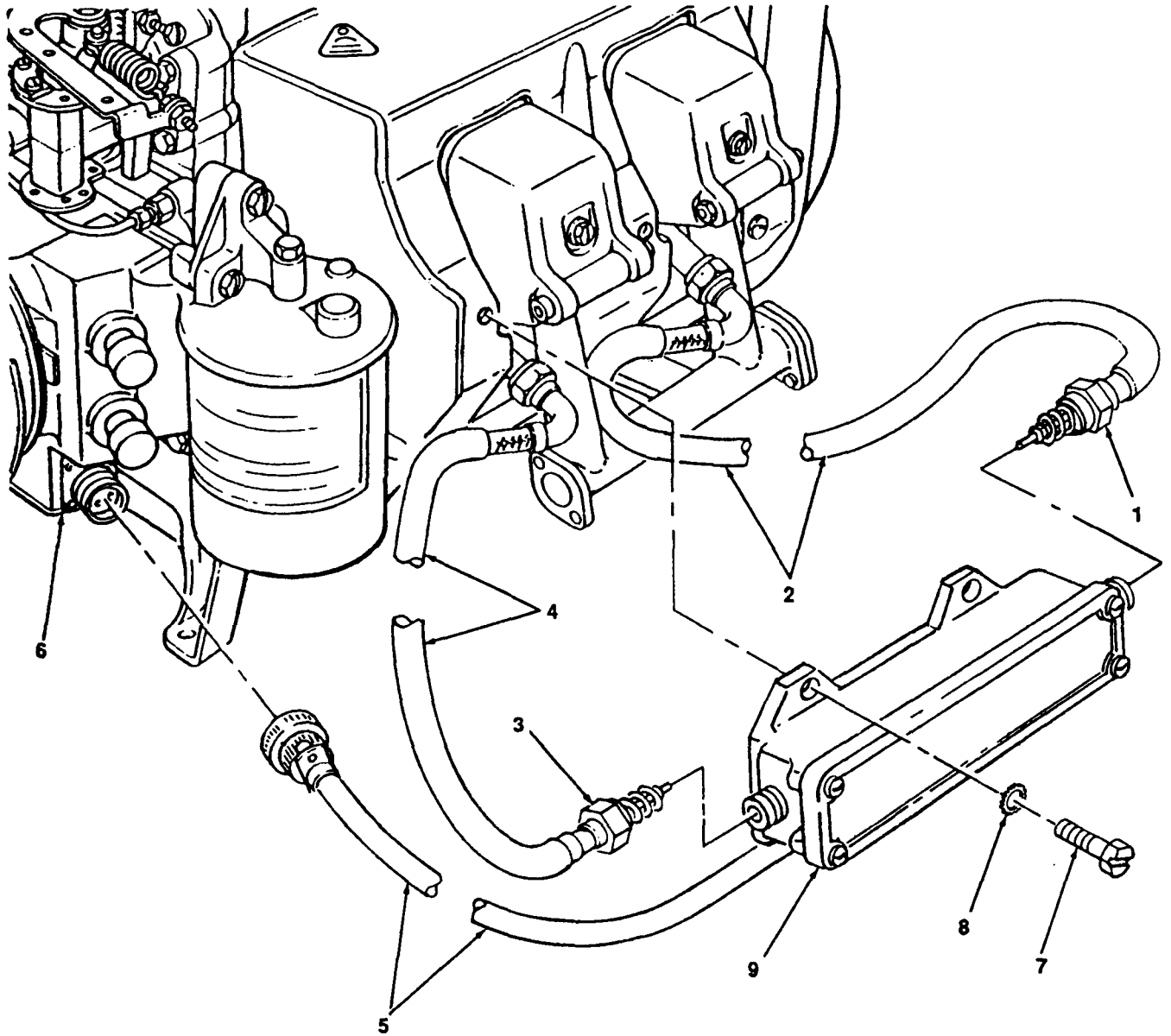

4868-064

Figure 5-9. Ignition Control Unit, Removal and Installation.

5-13. Transformer (Breakerless Ignition).

This task covers: a. Removal b. Installation

INITIAL SETUP

Tools

General Mechanic's Tool Kit (Item 1, Appendix B)

a. Removal. (figure 5-10)

NOTE

There are five screws securing cover on left hand side of engine.

- (1) Remove four screws (1) and remove cover (2) and gasket (3).
- (2) Loosen connector nut (4) and remove high tension cable (5).
- (3) Tag and remove transformer leads.
- (4) Remove nut (6) and washer (7) and remove transformer (8) and O-ring (9).

b. Installation. (figure 5-10)

- (1) Install transformer (8) and O-ring (9) and secure with nut (6) and washer (7).
- (2) Connect transformer leads as tagged.
- (3) Install high tension cable (5) and tighten connector nut (4).
- (4) Install cover (2) and gasket (3) and secure with four screws (1).

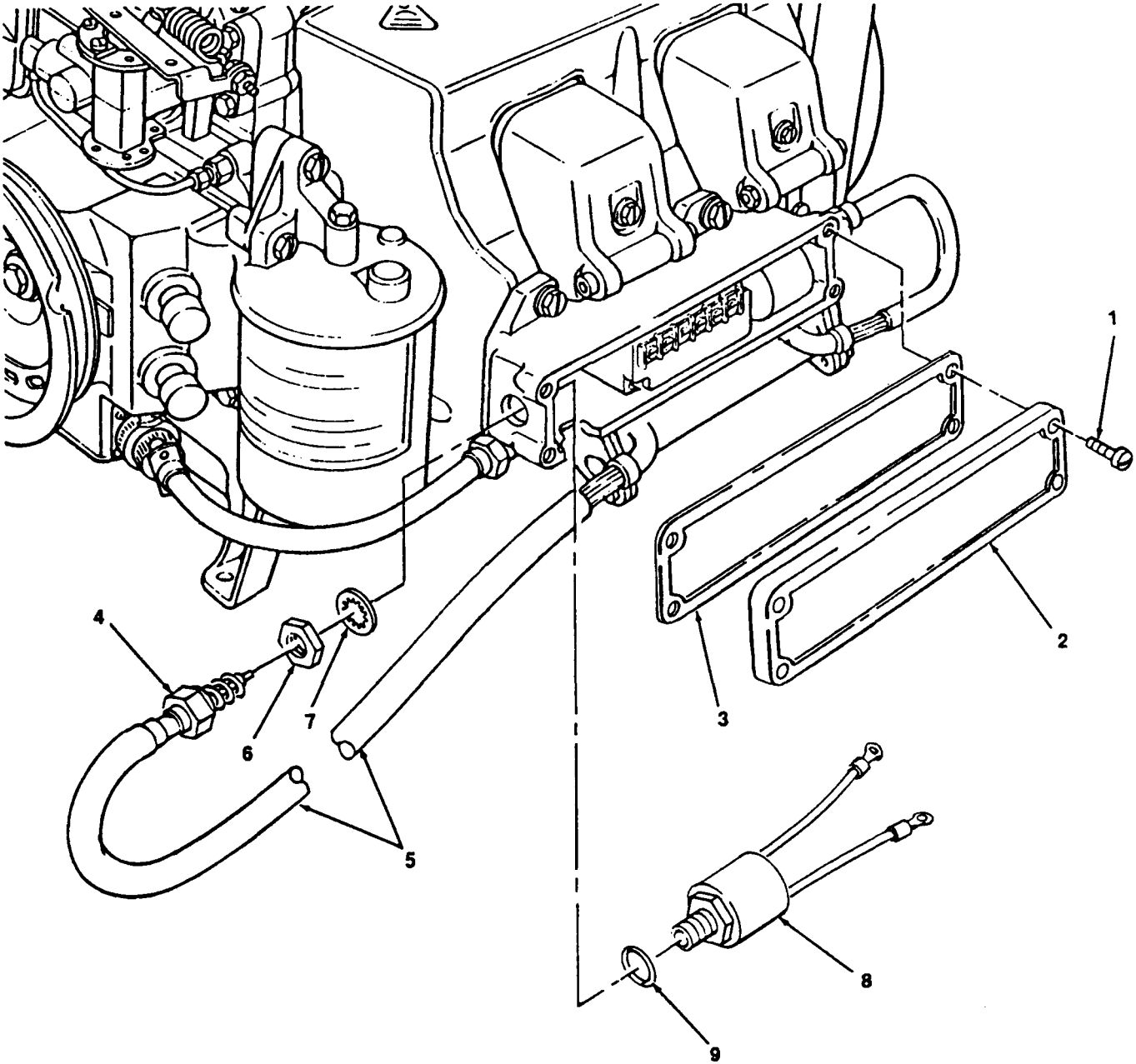

4868-065

Figure 5-10. Transformer, Removal and Installation.

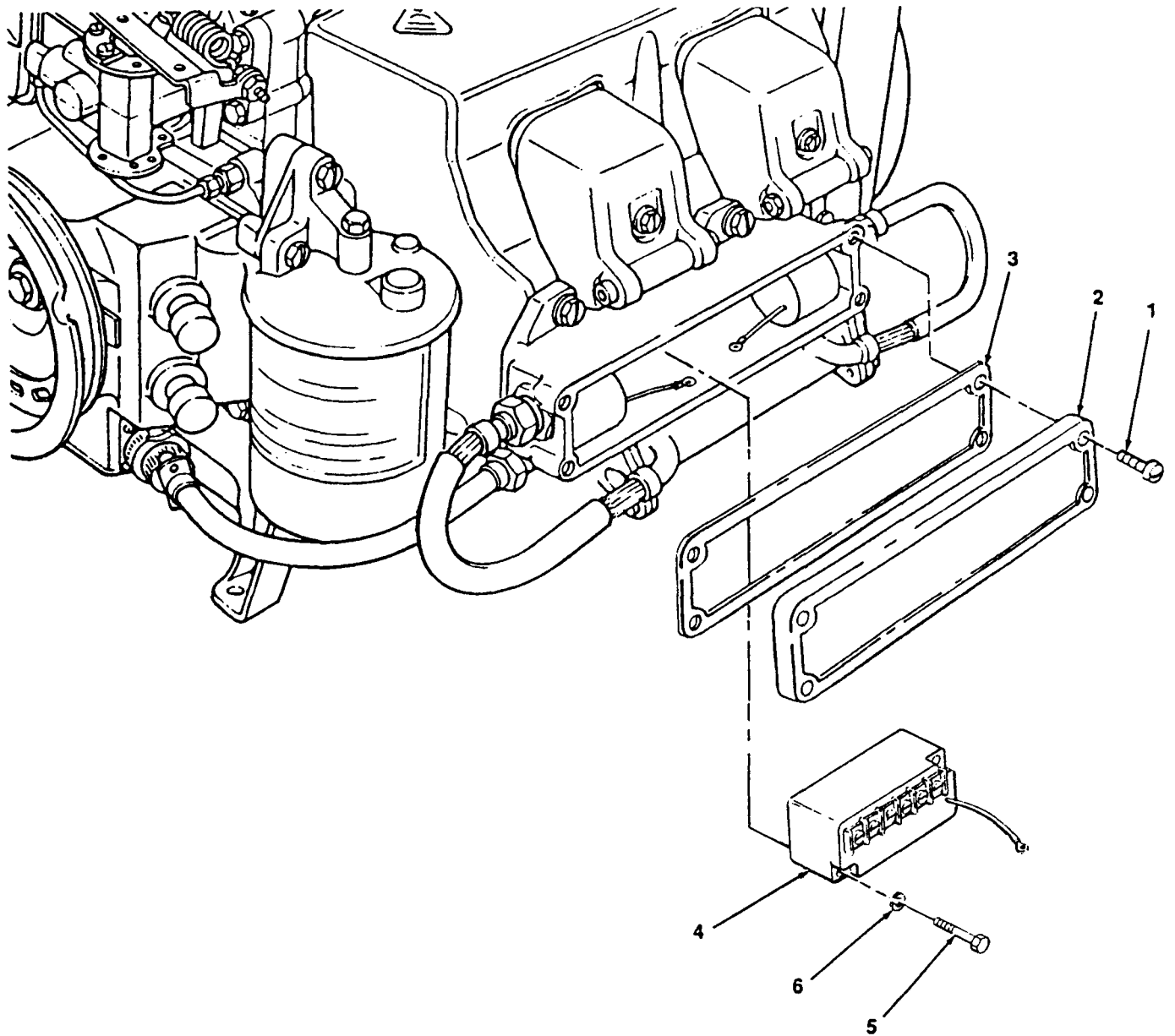

Figure 5-11. Ignition Module, Removal and Installation.

5-15. Junction Box (Breakerless Ignition).

This task covers: a. Removal b. Installation

INITIAL SETUP

<i>Tools</i>	<i>Equipment Condition</i>
General Mechanic's Tool Kit (Item 1, Appendix B)	Coil rover removed (para. 4-47).

a. Removal. (figure 5-12)

- (1) Loosen protective cap (1) and pull lead (2) through coil cover (3).
- (2) Remove two nuts (4) and washers (5), and remove junction box (6) from coil cover (3).

b. Installation. (figure 5-12)

- (1) Install junction box (6) and secure with two nuts (4) and washers (5).
- (2) Feed lead (2) through protective cap (1) and install protective cap (l).

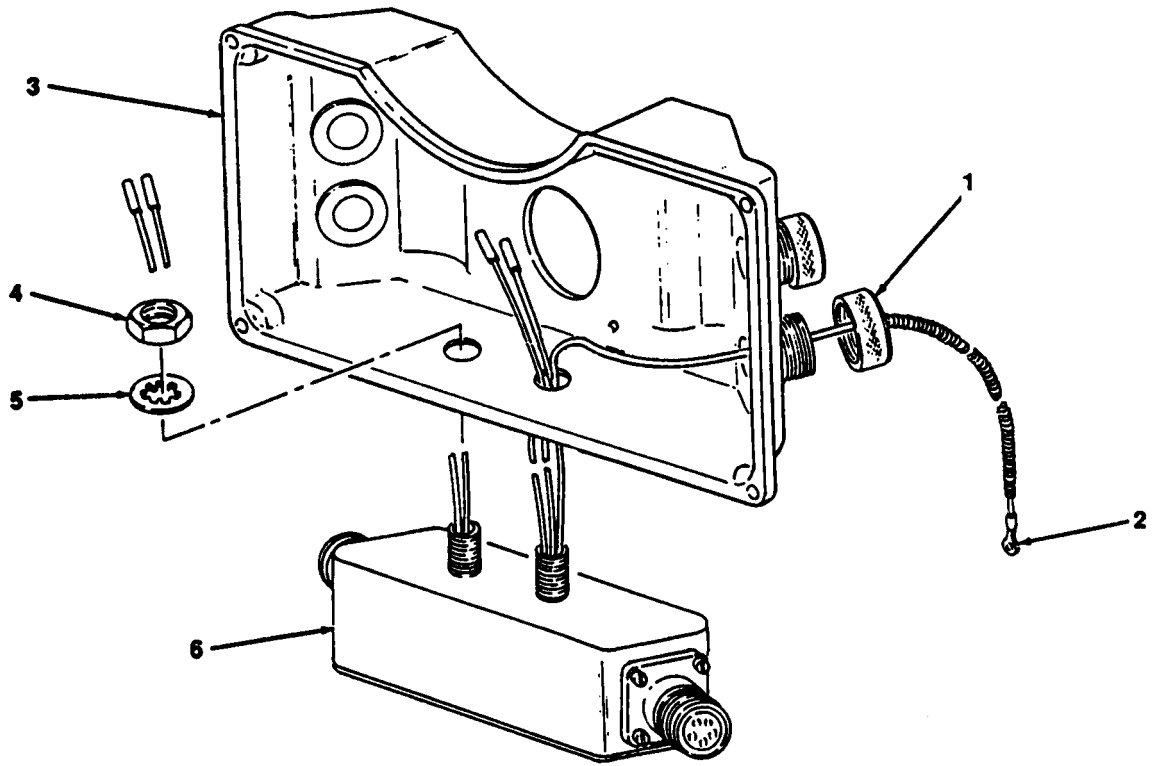

4868-067

Figure 5-12. Junction Box, Removal and Installation.

5-16. Low Voltage Cable (Breakerless Ignition).

This task covers: a. Removal b. Installation

INITIAL SETUP

Tools

General Mechanic's Tool Kit (Item 1, Appendix B)

a. Removal. (figure 5-13)

NOTE

There are five screws securing cover on left hand side of engine.

- (1) Remove four screws (1) and remove ignition control unit cover (2) and gasket (3).
- (2) Tag and remove low voltage cable leads from ignition control unit (4). Refer to figure 5-26 for wiring diagram.
- (3) Loosen connector nut (5) and remove low voltage cable (6) from ignition control unit (4).
- (4) Loosen connector (7) and remove low voltage cable from junction box (8).

b. Installation. (figure 5-13)

- (1) Connect low voltage cable (6) to junction box (8) and tighten connector (7).
- (2) Connect low voltage cable (6) to ignition control unit (4) and tighten connector nut (5),
- (3) Connect low voltage cable leads as tagged.
- (4) Install cover (2) and gasket (3) and secure with four screws (1).

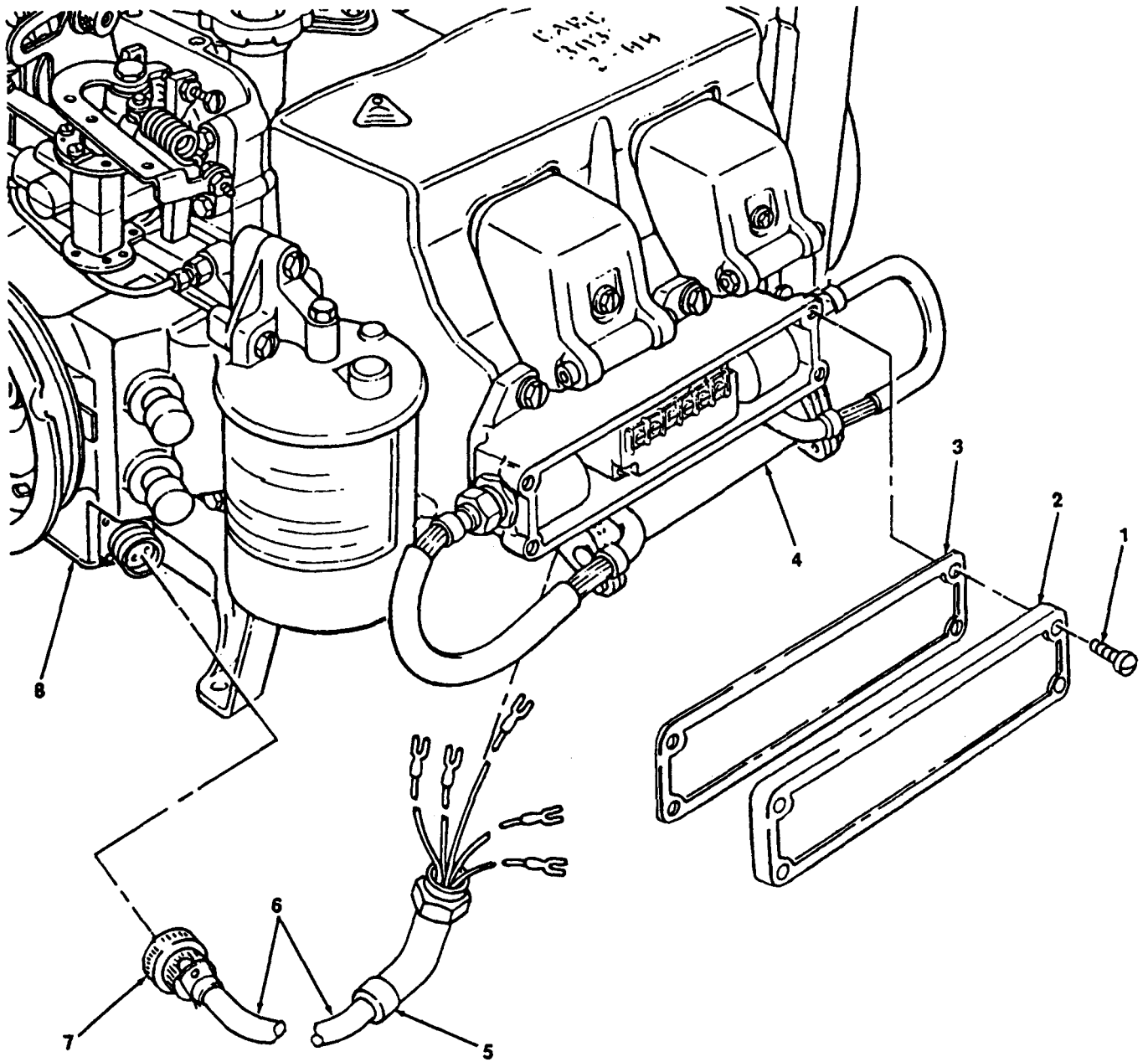

4868-090

Figure 5-13. Low Voltage Cable, Removal and Installation.

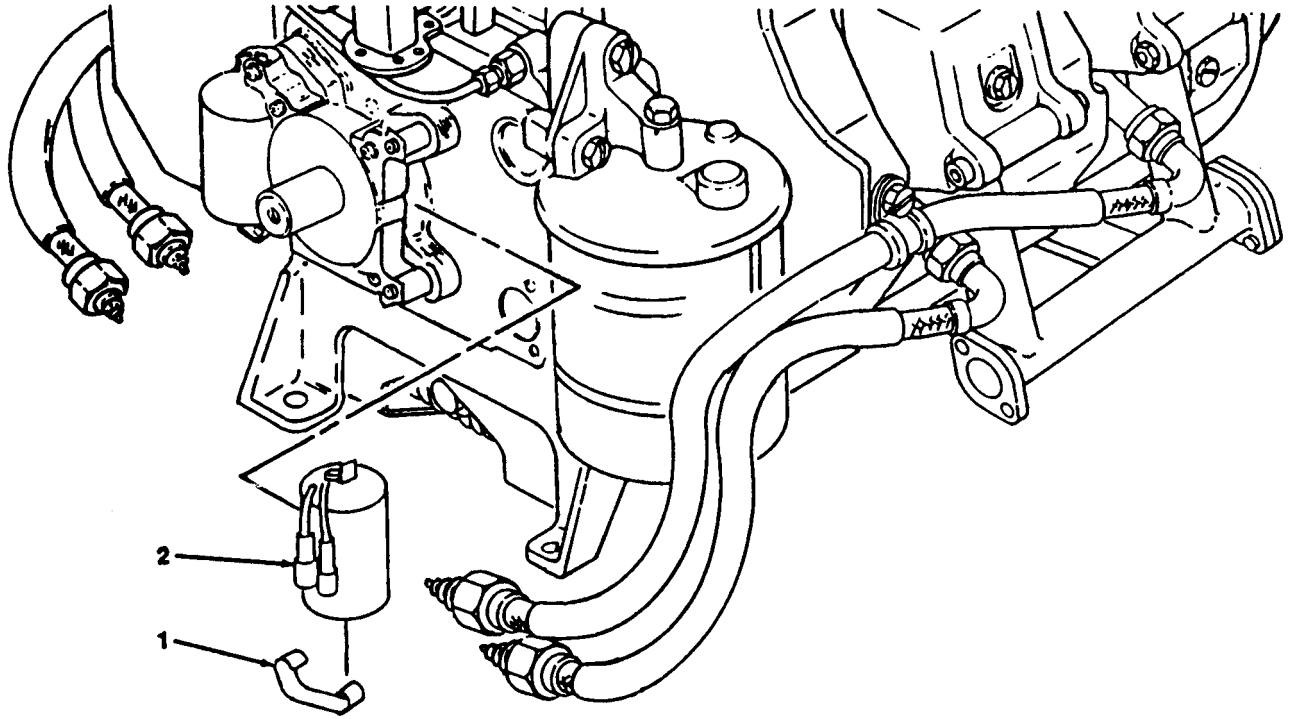

4868-068

Figure 5-14. Coil, Removal and Installation.

5-18. Oil Pump Cover.

This task covers: a. Removal b. Inspection c. Installation

INITIAL SETUP

Tools

General Mechanic's Tool Kit (Item 1, Appendix B)

Materials/Parts

Rags, Wiping (Item 7, Appendix D)
Solvent, Drycleaning (Item 8, Appendix D)
Gasket, Oil Pump Housing Mounting
(P/N 13206E0326)

Equipment Condition

Breaker point cover removed (para. 4-44).
Condensers removed (para. 4-46).
Breaker points removed (para. 4-49).

a. Removal. (figure 5-15)

NOTE

Step 1 is for engines with breakerless ignition.

- (1) Remove screw (1) and washer (2) securing loop clamp (3) and remove lead (4).
- (2) Remove eight screws (5) and washers (6) and remove oil pump cover (7) and gasket (8).

b. Inspection.

WARNING

Drycleaning solvent PD-660 used to clean parts is potentially dangerous to personnel and property. Avoid repeated and prolonged skin contact. Do not use near open flame or excessive heat. Flash point of solvent is 100°F-138°F (38°C-60°C).

- (1) Clean oil pump cover with drycleaning solvent, and dry thoroughly.
- (2) Inspect oil pump cover and replace if cracked or otherwise damaged.

c. Installation. (figure 5-15)

- (1) Ensure all gasket surfaces are clean and old gasket material is removed.
- (2) Install oil pump cover (7) and new gasket (8) and secure using eight screws (5) and washers (6).

NOTE

Step 3 is for engines with breakerless ignition.

- (3) Install lead (4) and secure with loop clamp (3), screw (1) and washer (2).

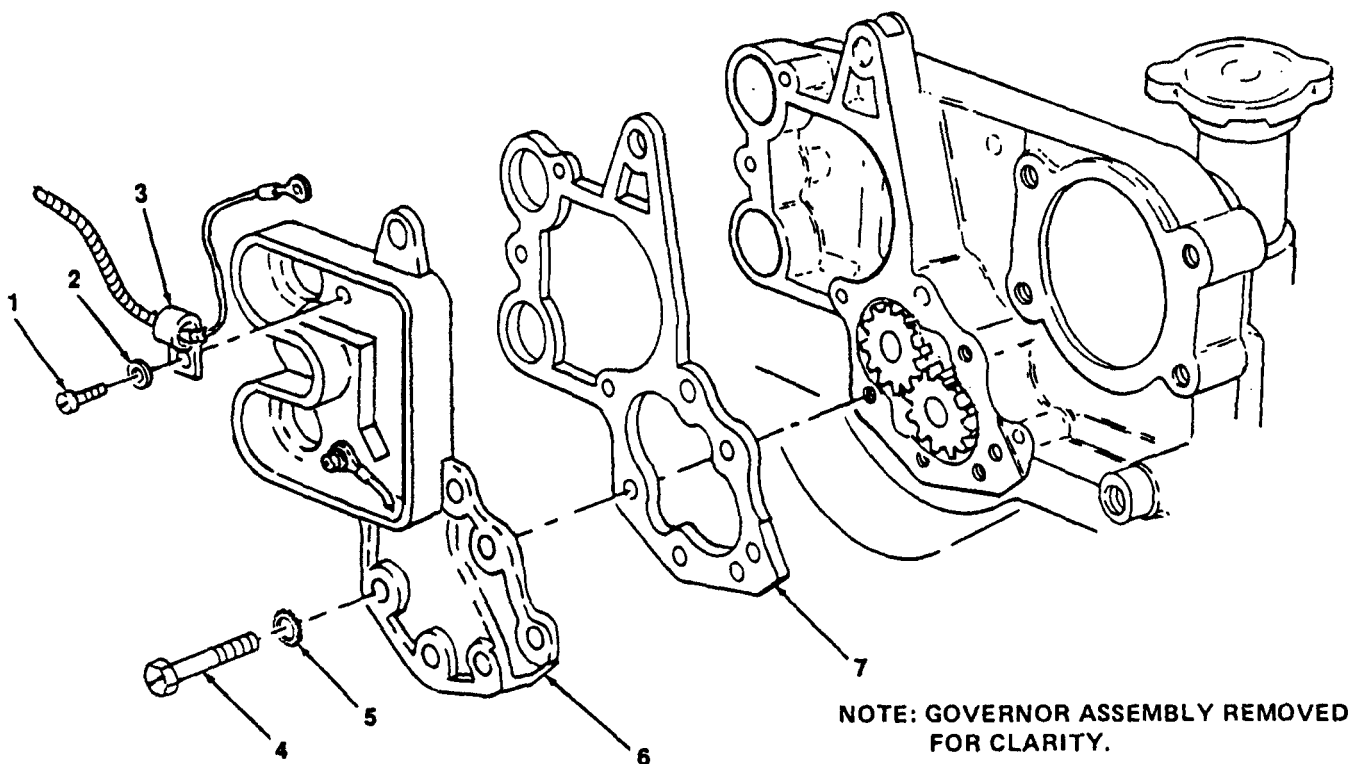

Figure 5-15. Oil Pump Cover, Removal and Installation.

4868-069

5-19. Oil Pump Gears and Wear Plate.

This task covers: a. Removal b. Inspection c. Installation

INITIAL SETUP

Tools

General Mechanic's Tool Kit (Item 1, Appendix B)

Equipment Condition

Oil pump cover removed (para. 5-18).

Materials/Parts

Rags, Wiping (Item 7, Appendix D)

Solvent, Drycleaning (Item 8, Appendix D)

a. Removal. (figure 5-16)

- (1) Remove oil pump gears (1) from end cover (2).
- (2) Remove wear plate (3) from end cover (2).

b. Inspection.

WARNING

Drycleaning solvent PD-680 used to clean parts is potentially dangerous to personnel and property. Avoid repeated and prolonged skin contact. Do not use near open flame or excessive heat. Flash point of solvent is 100°F-138°F (38°C-600C).

- (1) Clean all items in drycleaning solvent, and dry thoroughly.
- (2) Inspect items for excessive wear, and replace worn or otherwise damaged items. Refer to table 5-2 for wear limits.

c. Installation. (figure 5-16)

- (1) Install wear plate (3).
- (2) Install oil pump gears (1).

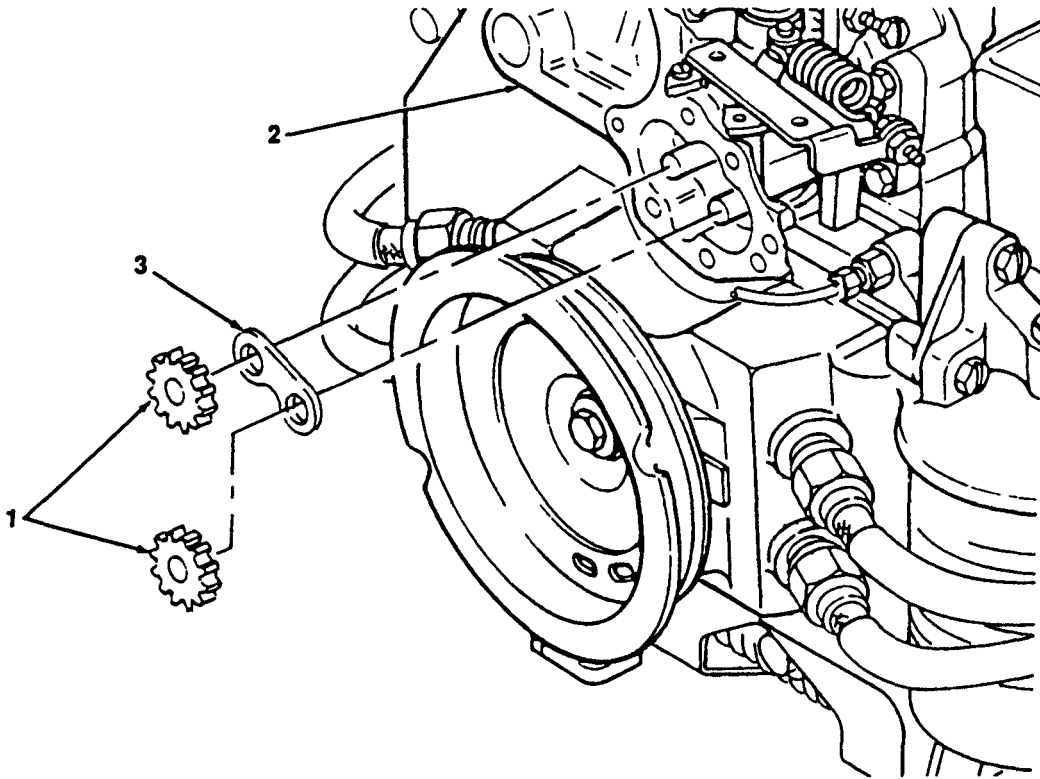

4868-070

Figure 5-16. Oil Pump Gears and Wear Plate, Removal and Installation.

5-20. Oil Pan and Screen.

This task covers: a. Removal b. Inspection c. Installation

INITIAL SETUP

Tools

General Mechanic's Tool Kit (Item 1, Appendix B)

Equipment Condition

Drain plug removed (para. 4-41).
Oil pan cover removed (para. 4-35).

Materials/Parts

Rags, Wiping (Item 7, Appendix D)
Solvent, Drycleaning (Item 8, Appendix D)
Gasket, Oil Pan Mounting (NSN 5330-00-867-8775)

a. Removal. (figure 5-17)

- (1) Remove twelve screws (1) and washers (2) and remove oil pan (3) and gasket (4).
- (2) Remove two screws (5) and washers (6) and remove oil pan screen (7).

b. Inspection. (figure 5-17)

WARNING

Drycleaning solvent PD-680 used to clean parts is potentially dangerous to personnel and property. Avoid repeated and prolonged skin contact. Do not use near open flame or excessive heat. Flash pint of solvent is 100°F-138°F (38°C-60°C).

- (1) Clean all items in drycleaning solvent, and dry thoroughly.
- (2) Inspect oil pan (3) for cracks and replace if cracked or otherwise damaged.
- (3) Inspect oil pan screen (7) and replace if torn or otherwise damaged.

c. Installation. (figure 5-17)

- (1) Install oil pan screen (7) and secure with two screws (5) and washers (6).
- (2) Install oil pan (3) and gasket (4) and secure with twelve screws (1) and washers (2).

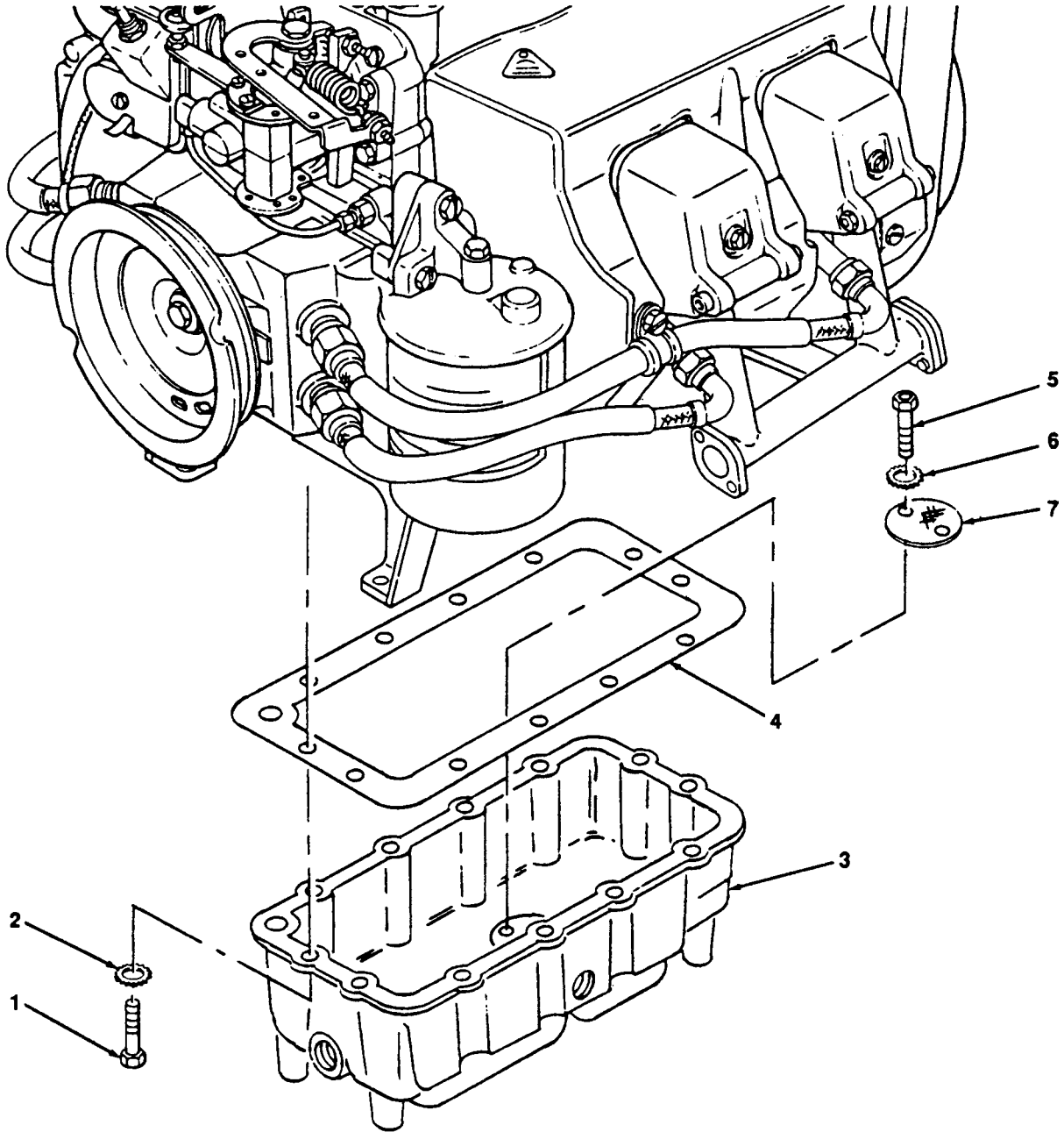

4868-071

Figure 5-17. Oil Pan, Removal, Inspection and Installation.

5-21. Drain Tube.

This task covers: Replacement

INITIAL SETUP

Tools

General Mechanic's Tool Kit (Item 1, Appendix B)

Equipment Condition

Cylinder head covers removed (para. 4-34).

Materials/Parts

Rags, Wiping (Item 7, Appendix D)

Solvent, Drycleaning (Item 8, Appendix D)

NOTE

The replacement procedures are the same for all drain tubes.

Replacement. (figure 5-18)

- (1) Loosen compression fitting (1).
- (2) Loosen coupling nut (2) and remove drain tube (3).

WARNING

Drycleaning solvent PD-680 used to clean parts is potentially dangerous to personnel and property. Avoid repeated and prolonged skin contact. Do not use near open flame or excessive heat. Flash point of solvent is 100°F-138°F (38°C-60°C).

- (3) Clean drain tube (3) in drycleaning solvent and dry thoroughly.
- (4) Inspect threads on compression fitting(1) and coupling nut (2) and replace if threads are stripped or otherwise damaged.
- (5) Remove all obstructions in drain tube (3), and replace drain tube if dented or otherwise damaged.
- (6) Install drain tube (3) and tighten coupling nut (2) and compression fitting (1).

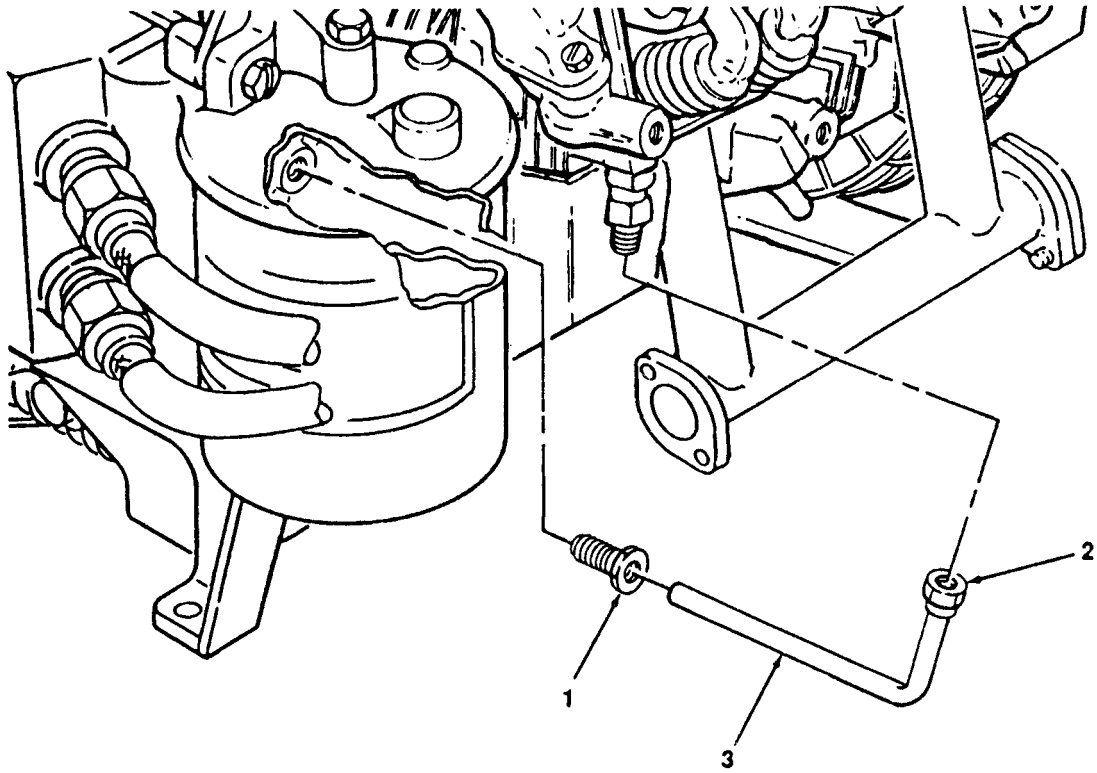

4868-088

Figure 5-18. Drain Tube, Replacement.

5-22. Piston and Connecting Rod Assembly.

This task covers: a. Removal b. Repair c. Installation

INITIAL SETUP

Tools

General Mechanic's Tool Kit (Item 1, Appendix B)
Ring Compressor (NSN 5120-00-250-6055)
(Item 3, Appendix B)
Wrench, Torque (NSN 51 20-00-640-6364)
(Item 5, Appendix B)

Materials/Patts (cont)

Lockwasher, Tab (P/N 9786E1 13-2)
Ring, Retaining (NSN 5365-00-070-1928)
Bolt (P/N 9786E1 13-3)

Equipment Condition

Materials/Patts

Rags, Wiping (Item 7, Appendix D)
Solvent, Drycleaning (Item 8, Appendix D)

Oil pan removed (para. 5-20).
Cylinder heads removed (para. 5-7)

NOTE

The following procedures are the same for all piston and connecting rod assemblies.

a. Removal. (figure 5-19).

WARNING

Drycleaning solvent PD-680 used to clean parts is potentially dangerous to personnel and property. Avoid repeated and prolonged skin contact. Do not use near open flame or excessive heat. Flash point of solvent is 100°F-138°F (38°C-60°C).

NOTE

Bearing cap and rod are matched sets and are installed in same cylinder as removed.

- (1) Remove carbon deposits from top of cylinder wall(1) and piston (2) and clean with drycleaning solvent.
- (2) Bend tangs on lockwasher (3).
- (3) Remove two bolts (4), lockwasher (3), and remove connecting rod bearing cap (5).
- (4) Push piston and connecting rod assembly (6) out of cylinder (7).

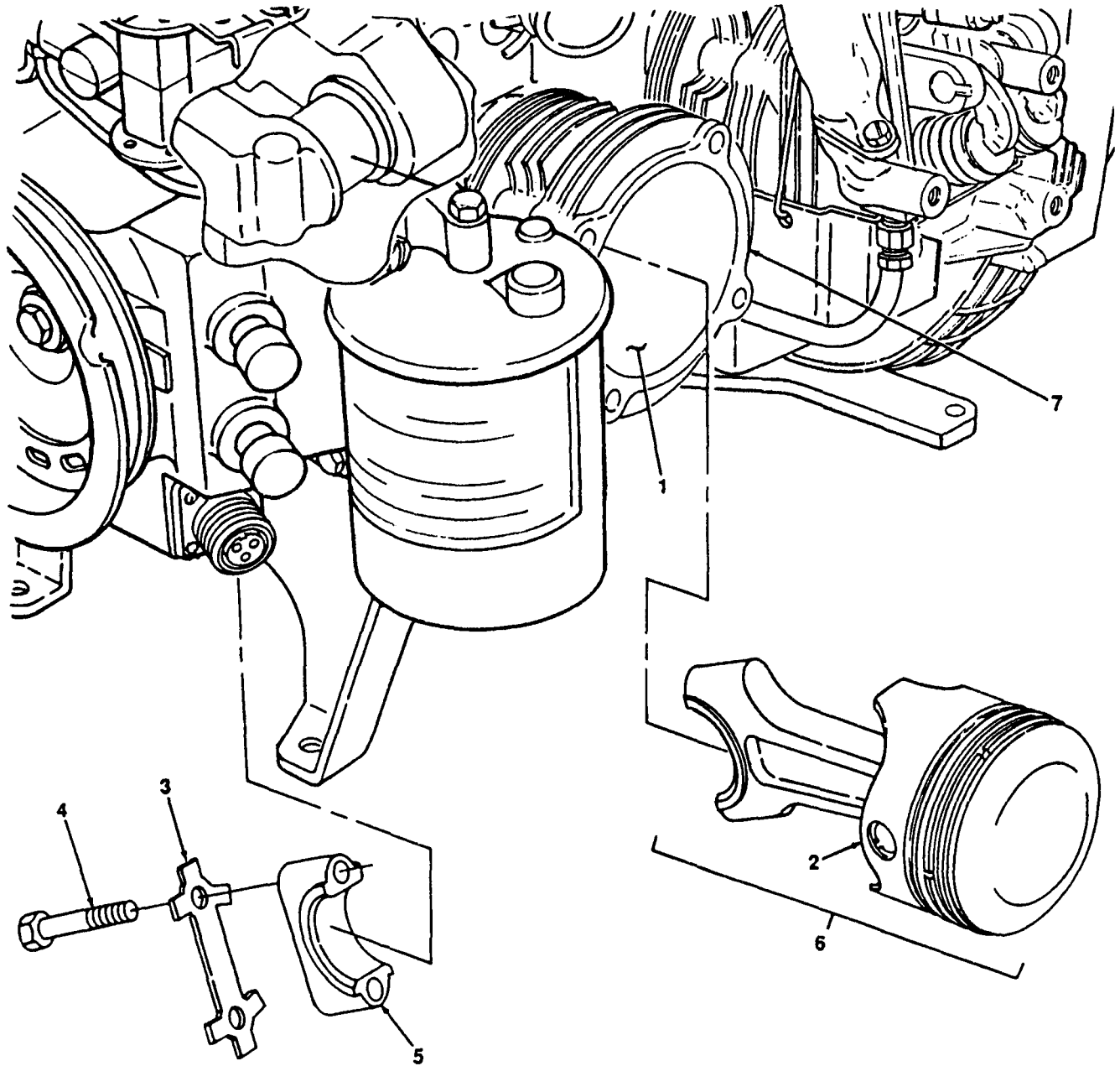

4868-072

Figure 5-19. Piston and Connecting Rod Assembly, Removal.

5-22. Piston and Connecting Rod Assembly (cont).

b. Repair. (figure 5-20)

- (1) Remove two retaining rings (1), and remove piston pin (2) and connecting rod (3).
- (2) Remove spacer ring (4), top compression ring (5), compressing ring (6), oil ring (7), and oil expander ring (8) from piston (9).

WARNING

Drycleaning solvent PD-680 used to clean parts is potentially dangerous to personnel and property. Avoid repeated and prolonged skin contact. Do not use near open flame or excessive heat. Flash point of solvent is 100°F-138°F (38°C-60°C).

- (3) Clean all items in drycleaning solvent and dry thoroughly.
- (4) Inspect piston (9), connecting rod (3), piston pin (2), connecting rod bearing cap (10), and bolts(11) for wear and replace worn or damaged components. Refer to table 5-2 for wear limits.

NOTE

Do not reuse piston rings, retaining rings, or lockwasher (12).

- (5) Install oil expander ring (8), oil ring (7), compression ring (6), top compression ring (5) and spacer ring (4),
- (6) Install connecting rod (3) in piston (9) and install piston pin (2) and two retaining rings (1).

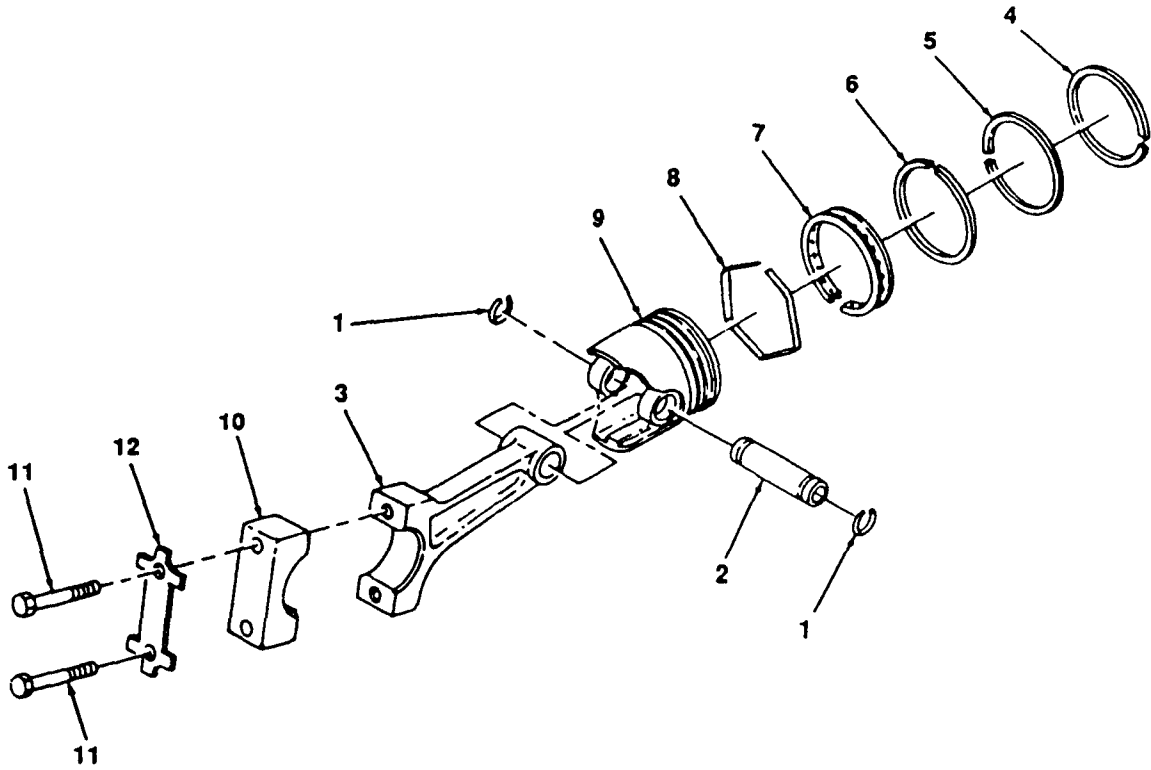

4868-073

Figure 5-20. Piston and Connecting Rod Assembly, Repair.

5-22. **Piston and Connecting Rod Assembly (cont).**

c. Installation. (figure 5-21)

NOTE

Offset gaps in rings.

- (1) Using ring compressor, install piston and connecting rod assembly (6) in cylinder (7).
- (2) Install connecting rod (8) on crankshaft (9).
- (3) Install connecting rod bearing cap (5) and new lockwasher (3) and secure with two new bolts (4).
Torque bolts to 96-108 in.-lb (11064-12447 gr cm).
- (4) Bend tangs on lockwasher (3).

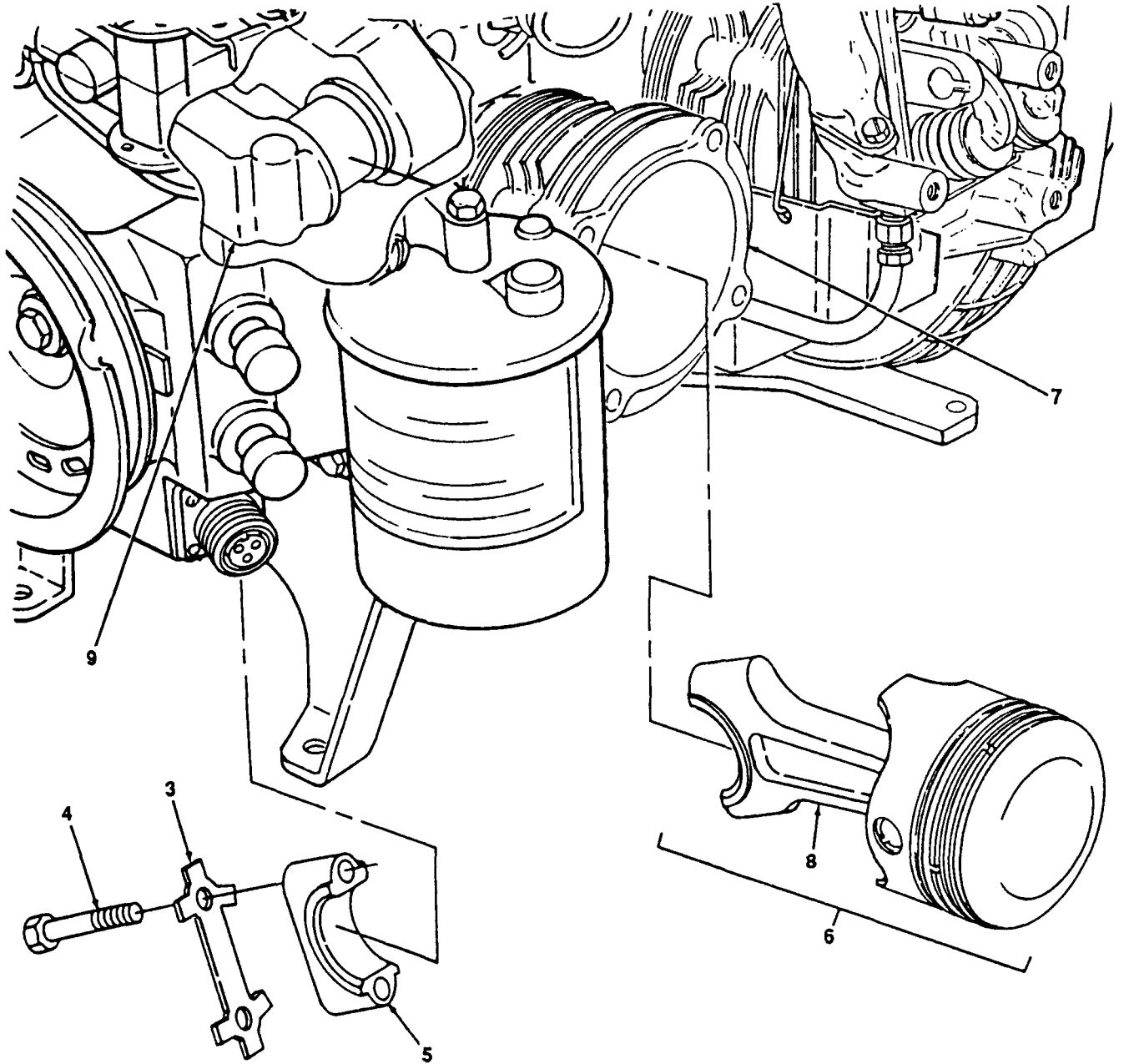

4868-074

Figure 5-21. Piston and Connecting Rod Assembly, installation.

5-23. Flywheel.

This task covers: a. Removal b. Installation

INITIAL SETUP

<i>Tools</i>	<i>Materials/Parts</i>
General Mechanic's Tool Kit (Item 1, Appendix B) Puller, Kit Mechanical (NSN 5120-00-423-1596) (Item 3, Appendix B) Wrench, Torque (NSN 5120-00-640-6364) (Item 5, Appendix B)	Bolt, Flywheel (P/N 13218 E0528-722)

a. Removal. (figure 5-22)

- (1) Remove bolt (1) and washer (2).
- (2) Using suitable puller, remove flywheel (3) and key (4) from crankshaft (5).

b. Installation. (figure 5-22)

- (1) Install key (4) in slot on crankshaft (5),
- (2) Install flywheel (3) on crankshaft (5) and secure with bolt(1) and washer (2). Torque bolt(1) to 37-40 ft lb (78585-85729 gr cm).

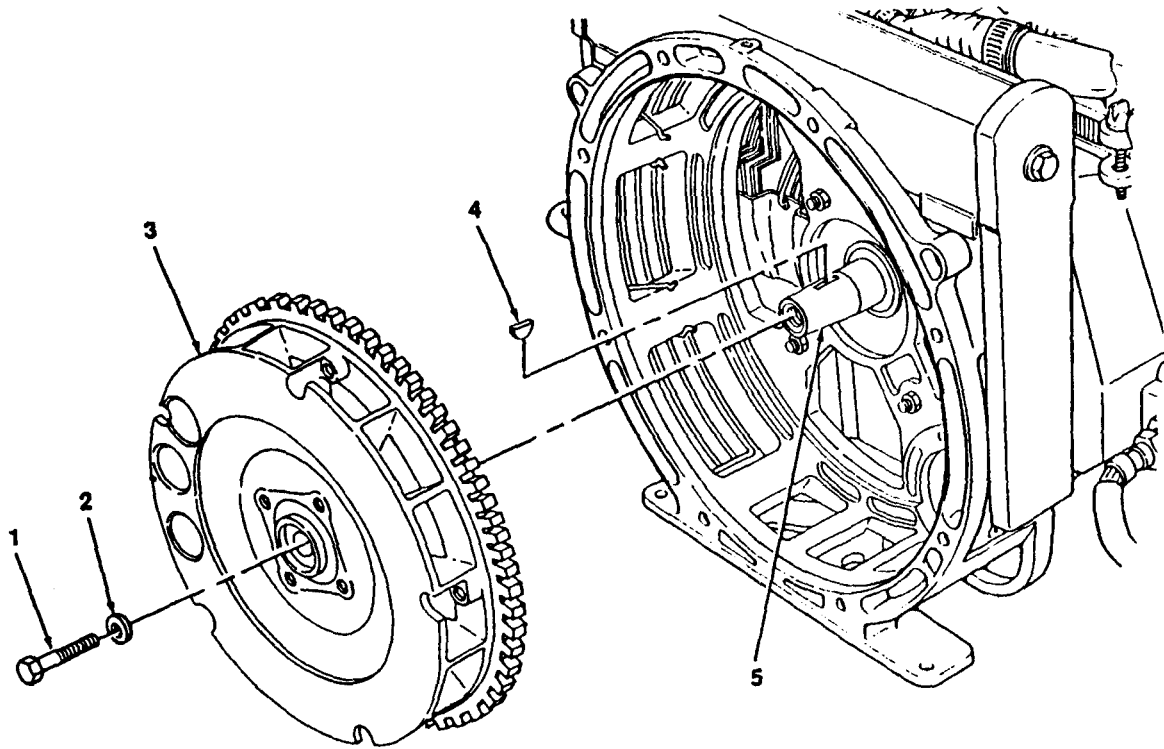

4868-075

Figure 5-22. Flywheel, Removal and Installation.

5-24. Flywheel Housing and Protective Screen.

This task covers: a. Removal b. Inspection c. Installation

INITIAL SETUP

Tools

Equipment Condition

General Mechanic's Tool Kit (Item 1, Appendix B)

Winterization shroud removed (para. 4-33).
Flywheel removed (para.5-23).

a. Removal. (figure 5-23)

- (1) Remove three screws (1) and remove rear engine bracket (2).
- (2) Remove four clips (3), screw (4), washer (5), and remove protective screen (6).
- (3) Remove four nuts (7), washers (8), and remove flywheel housing (9).

b. Inspection. (figure 5-23)

- (1) Inspect protective screen (6) and replace if bent or otherwise damaged.
- (2) Inspect flywheel housing (9) and notify general support maintenance if flywheel housing (9) is cracked or otherwise damaged.

c. Installation. (figure 5-23)

- (1) Install flywheel housing (9) and secure with four nuts (7) and washers (8).
- (2) Install protective screen (6) and secure with screw (4), washer (5) and four clips (3).
- (3) Install rear engine bracket (2) and secure with three screws (1).

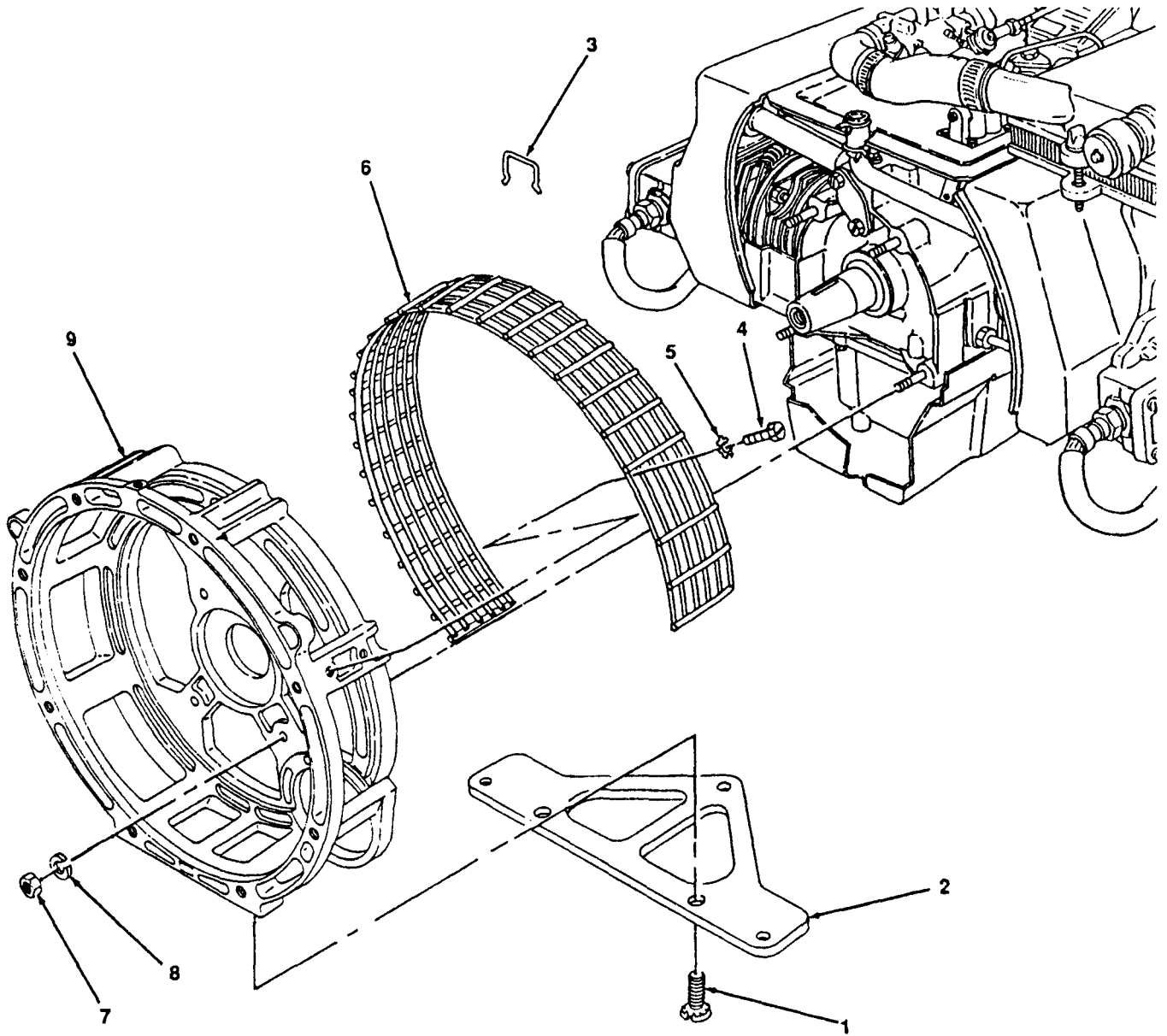

4868-076

Figure 5-23. Flywheel Housing and Protective Screen, Removal, Inspection and Installation.

5-25. Oil Pressure Regulating Valve Assembly.

This task covers: Replacement

INITIAL SETUP

Tools

General Mechanic's Tool Kit (Item 1, Appendix B)

Materials/Pads

Rags, Wiping (Item 7, Appendix D)
Solvent, Drycleaning (Item 8, Appendix D)

Replacement. (figure 5-24)

(1) Remove plug (1) and remove washer (2), spring (3), and piston (4).

WARNING

Drycleaning solvent PD-680 used to clean parts is potentially dangerous to personnel and property. Avoid repeated and prolonged skin contact. Do not use near open flame or excessive heat. Flash point of solvent is 100°F-138°F (38°C-60°C).

(2) Clean all items with drycleaning solvent, and dry thoroughly.

(3) Inspect items and replace any item that is worn, cracked or otherwise damaged.

(4) Install piston (4), spring (3), washer (2) and plug (1).

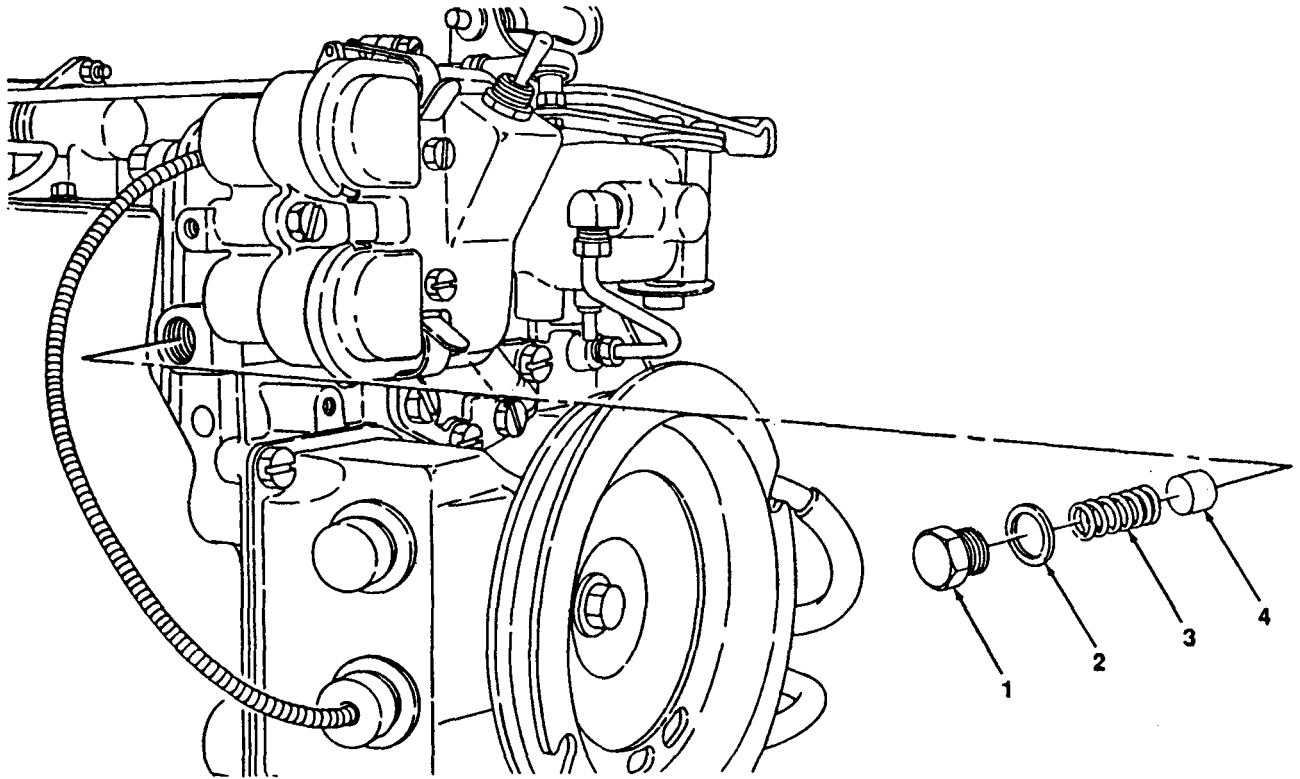

4868-077

Figure 5-24. Oil Pressure Regulating Valve Assembly, Replacement.

5-26. Oil Filler Tube and Gage.

This task covers: Replacement

INITIAL SETUP

Tools

General Mechanic's Tool Kit (Item 1, Appendix B)
Rubber Mallet

Equipment Condition

Top cover removed for replacement of oil filler
(para. 4-36).

Replacement. (figure 5-25)

- (1) Remove oil gage (1).

NOTE

Perform step (2) only if oil filler tube is damaged and needs to be replaced.

- (2) Gently tap oil filler (2) on both sides and remove.
- (3) Inspect oil gage (1) and replace if bent or otherwise damaged.
- (4) Install oil filler (2) and gently tap straight into crankcase with rubber mallet.
- (5) Install oil gage (1).

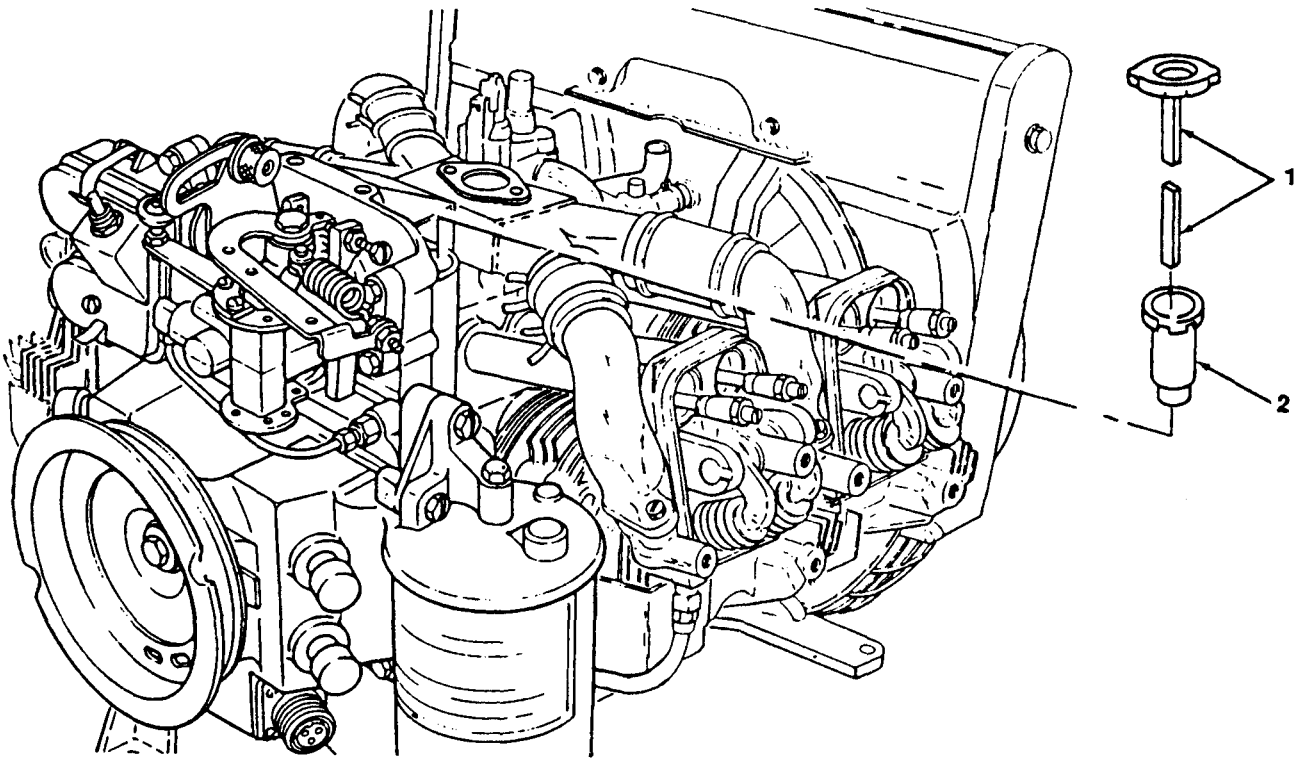

4868-078

Figure 5-25. Oil Filler Tube and Gage, Replacement.

5-27. Crankcase Oil Seal.

This task covers: Replacement

INITIAL SETUP

Tools

General Mechanic's Tool Kit (Item 1, Appendix B)
Kit, Puller (NSN 5120-00-423-1596) (Item 3,
Appendix B)

Equipment Condition

Flywheel removed (para. 5-23).

Replacement. (Figure 5-25.1)

- (1) Using tools, remove oil seal (1) from crankcase (2).
- (2) Clean oil seal mounting surfaces.
- (3) Install new oil seal (1) in crankcase (2).

Change 2 5-56

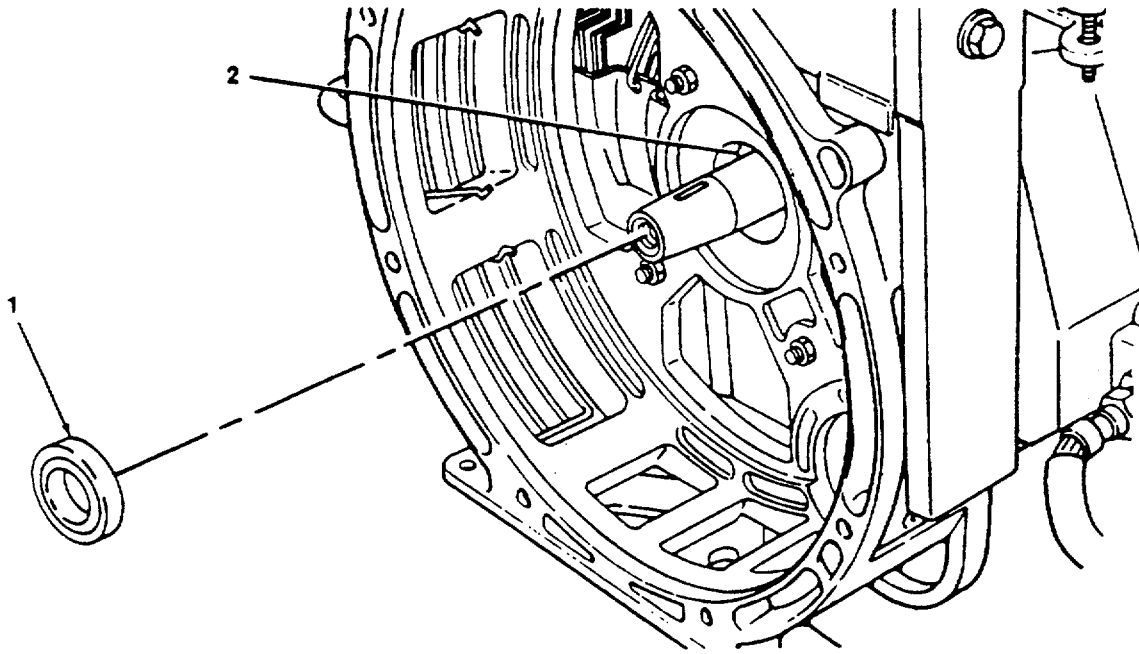

4868-093

Figure 5-25.1. Crankcase Oil Seal, Replacement.

Change 2 5-56.1

Table 5-2. Engine Repair and Replacements Limits.

Item	Measurements	
	Maximum*	Minimum*
CONNECTING RODS		
Side Clearance	0.0400 (0.1016)	0.0200 (0.0508)
Large End:		
I.D.	0.8798 (2.2347)	0.8789 (2.2324)
Journal clearance	0.0053 (0.0135)	0.0039 (.0099)
Small End:		
I.D.	0.4205 (1.0681)	0.4200 1.0668)
Pin clearance	0.0015 (0.0038)	0.0005 (0.0013)
PISTON		
Piston Pin O.D.	0.4195 (1.0655)	0.4190 (1.0643)
Piston Pin Hole Diameter	0.4203 (1.0676)	0.4195 (1.0655)
Clearance	0.0013 (0.0033)	0.0001 (0.0002)
Skirt O.D. (Bottom)	2.2505 (5.7163)	2.2485 (5.7112)
Clearance in Cylinder	0.0020 (0.0051)	0.0005 (0.0013)
Piston Rings:		
Gap clearance:		
Spacer	0.0450 (0.1143)	0.0005 (0.0013)
Top	0.0270 (0.0686)	0.0070 (0.0178)
Second	0.0270 (0.0696)	0.0070 (0.0178)
Third	0.0170 (0.0686)	0.0070 (0.0178)
Side Clearance		
First	0.0050 (0.0127)	0.0020 (0.0051)
Second	0.0035 (0.0089)	0.0015 (0.0038)
Third	0.0030 (0.0076)	0.0010 (0.0025)

Table 5-2. Engine Repair and Replacements Limits (cont).

Item	Measurements	
	Maximum*	Minimum*
VALVES		
Exhaust:		
Length to gage point	2.7885 (7.0828)	2.7850 (7.0739)
Stem diameter	0.3100 (0.7874)	0.3095 (0.7861)
Head diameter	0.8390 (2.1311)	0.8490 (2.1565)
Seat angle	45°5'	46°0'
Stem guide clearance	0.0020 (0.0051)	0.0045 (0.0114)
Intake:		
Length to gage point	2.7885 (7.0828)	2.7850 (7.0739)
Stem diameter	0.3100 (0.7874)	0.3105 (0.7887)
Head diameter	0.9010 (2.2885)	0.9110 (2.3139)
Seat angle	45°45'	45°0'
Stem to guide clearance	0.0045 (2.2352)	0.0020 (0.0051)
Springs:		
Pounds load (valve open)	42 (18.9kg)	41 (18kg)
Length (valve closed)	1.095 (2.7813)	1.095 (2.7813)
Pounds load (valve closed)	19 (8.55kg)	18 (8.10kg)
VALVE GUIDE		
Exhaust and intake:		
Stem clearance	0.0045 (0.0114)	0.0020 (0.0051)
Inside diameter	0.3145 (0.7983)	0.3125 (0.7937)
VALE SEAT INSERTS		
Exhaust:		
Inside diameter	0.7480 (1.8999)	0.7460 (1.8948)
Seat angle	45°0'	44°45'

Table 5-2. Engine Repair and Replacements Limits (cont).

Item	Measurements	
	Maximum*	Minimum*
Intake:		
Inside diameter	0.8150 (2.0701)	0.8050 (2.0447)
Seat angle	45°0'	44°45'
VALVE TAPPETS		
Outside diameter	0.4974 (1.2634)	0.4970 (1.2624)
Clearance in guide	0.0025 (0.0063)	0.0005 (0.0013)
Tappet guide I.D.	0.4995 (1.2687)	0.4984 (1.2659)
ROCKER ARMS		
Rocker shaft O.D.	0.4375 (1.1112)	0.4370 (1.1100)
Bearing I.D.	0.4390 (1.1151)	0.4380 (1.1125)
Wear plate thickness	0.0350 (0.0889)	0.0330 (0.0738)
ROTATING MAGNET		
Pole shoe clearance	0.0160 (0.0406)	0.0020 (0.0051)

*Measurements in inches (mm).

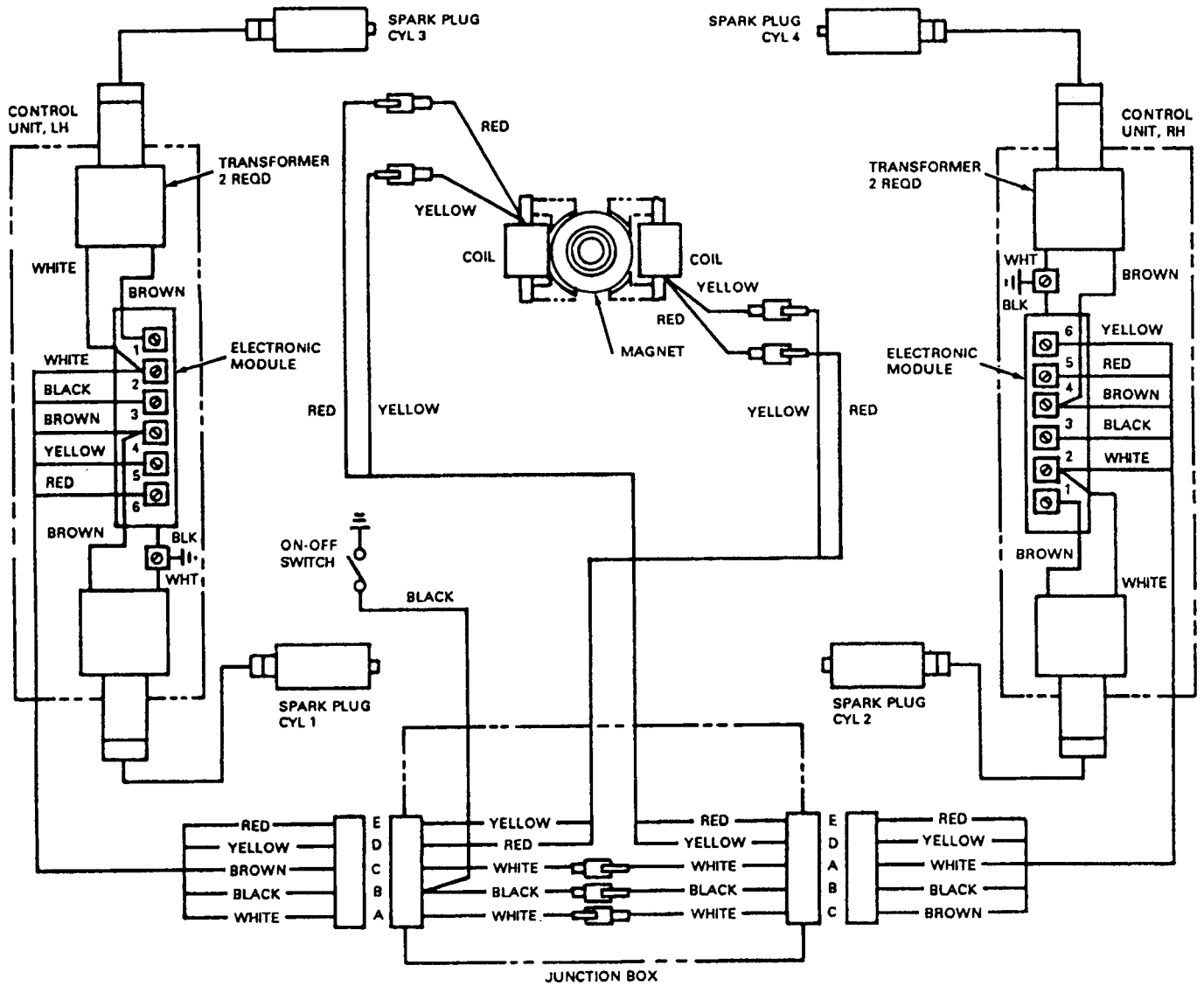

4868-091

Figure 5-26. Electronic Ignition Wiring Diagram.

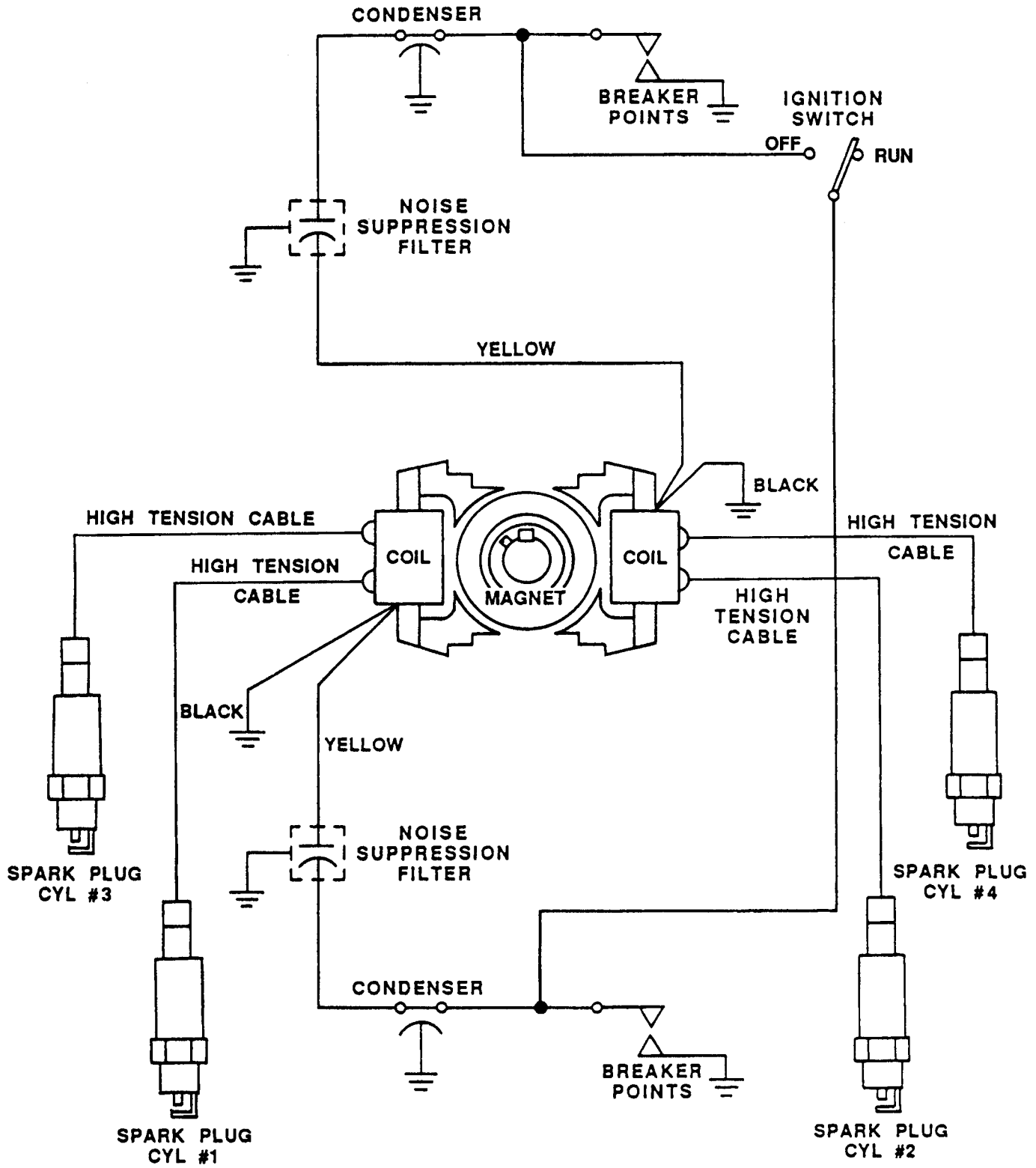

4868-095

Figure 5-27. Breaker Point Ignition System Wiring Diagram.

CHAPTER 6

GENERAL SUPPORT MAINTENANCE INSTRUCTIONS

	Page
OVERVIEW	6-1
Section I. Repair Parts; Special Tools; Test, Measurement, Diagnostic Equipment (TMDE); and Support Equipment	6-1
Section II. General Support Troubleshooting	6-1
Section III. General Support Maintenance Procedures	6-3

OVERVIEW

This chapter provides procedures for troubleshooting and maintenance of the 6 HP Military Standard Engine by General Support maintenance personnel.

Section I. REPAIR PARTS; SPECIAL TOOLS; TEST, MEASUREMENT, DIAGNOSTIC EQUIPMENT (TMDE); AND SUPPORT EQUIPMENT

Paragraph		Page
6-1	Common Tools and Test Equipment	6-1
6-2	Special Tools, TMDE, and Support Equipment	6-1
6-3	Repair Parts	6-1

6-1. Common Tools and Test Equipment. For authorized common tools and equipment, refer to the Modified Table of Organization and Equipment (MTOE) applicable to your unit.

6-2. Special Tools, TMDE, and Support Equipment. For a listing of special tools, TMDE, and support equipment authorized for use on this equipment, refer to the Repair Parts and Special Tools List, TM9-2805-262-24P, and the Maintenance Allocation Chart (MAC), appendix B of this manual.

6-3. Repair Parts. Repair parts are listed and illustrated in the Repair Parts and Special Tools List for 6 hp Military Standard Engine, TM 9-2805-262-24P.

Section II. GENERAL SUPPORT TROUBLESHOOTING

Paragraph		Page
6-4	General	6-1
6-5	General Support Troubleshooting Procedures	6-2

6-4. General. This section contains troubleshooting procedures to determine the probable cause of observed equipment malfunctions. Tests or inspections are provided to isolate the faulty component and corrective actions are provided to eliminate the malfunction.

6-5. General Support Troubleshooting Procedures. Table 3-1 lists the common malfunctions that may be found during operation. Refer to Symptom Index to locate the troubleshooting procedures for the malfunction. This manual cannot list all malfunctions that may occur, nor all tests or inspections and corrective actions. If a malfunction is not corrected by listed corrective actions, notify your supervisor.

SYMPTOM INDEX

Symptom	Page
Engine Runs Excessively Noisy	6-2
Engine Oil Consumption Excessive.	6-2

Table 6-1. General Support Troubleshooting Procedures.

Malfunction
Test or Inspection
Corrective Action

1. ENGINE RUNS EXCESSIVELY NOISY.

Step 1. Camshaft gear worn.

Replace a worn or otherwise damaged camshaft gear (para. 6-12).

Step 2. Camshaft worn.

Replace a worn or otherwise damaged camshaft (para. 6-12).

Step 3. Crankshaft worn.

Replace a worn or otherwise damaged crankshaft (para. 6-13).

Step 4. Crankshaft bearing worn.

Replace a worn or otherwise damaged crankshaft rear bearing (para. 6-15).

Step 5. End cover crankshaft bearing worn.

Replace a worn or otherwise damaged end cover crankshaft bearing (para. 6-10).

2. ENGINE OIL CONSUMPTION EXCESSIVE

Step 1. Check crankcase oil seal for wear.

Replace a worn or leaking crankcase oil seal (para. 6-16).

Step 2. Check end cover oil seal.

Replace a worn or leaking end cover oil seal (para. 6-11).

Section III. GENERAL SUPPORT MAINTENANCE PROCEDURES

Paragraph		Page
6-6	General.....	6-3
6-7	Flywheel	6-4
6-8	Flywheel Housing	6-6
6-9	End Cover	6-8
6-10	Crankshaft Bearing	6-10
6-11	End Cover Oil Seal.....	6-12
6-12	Camshaft, Camshaft Gear, Valve Tappets and Thrust Plate.....	6-14
6-13	Crankshaft and Center Main Bearing.....	6-18
6-14	Crankcase	6-22
6-15	Crankshaft Rear Bearing.....	6-24
6-16	<i>Deleted</i>	

6-6. General. This section contains general support maintenance procedures as authorized by the MAC in Appendix B of this manual. Table 6-2 at the end of this section, contains wear limits for those items maintained by general support maintenance. Those items which do not meet the specified measurements must be replaced. Refer to Appendix E for torque values. All maintenance procedures require only one person to perform.

Change 2 6-3

6-7. Flywheel.

This task covers: Repair

INITIAL SETUP

Tools

General Mechanic's Tool Kit (Item 1, Appendix B)

Equipment Condition

Flywheel removed (para.5-23).

Repair. (figure 6-1)

- (1) Inspect flywheel fan (1) and gear (2) for cracks and damaged or missing teeth.

NOTE

Perform step (2) only if damage is found.

- (2) Remove five screws (3), washers (4), and remove gear retaining ring (5) and gear (2).
- (3) Install gear (2) and gear retaining ring (5) and secure with five screws (3) and washers (4).

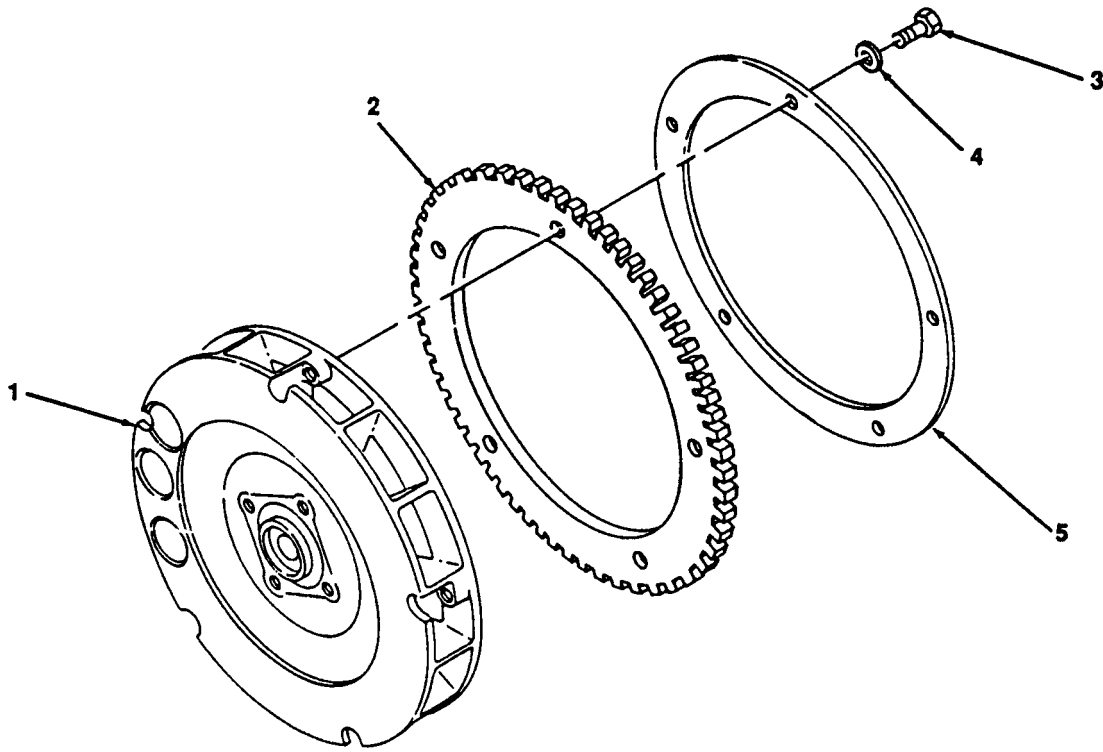

Figure 6-1. Flywheel, Repair.

4868-079

6-8. Flywheel Housing.

This task covers: Repair

INITIAL SETUP

Tools

General Mechanic's Tool Kit (Item 1, Appendix B)

Equipment Condition

Flywheel housing removed (para.5-24).

Personnel Required

44B

Repair. (figure 6-2)

- (1) Inspect flywheel housing (1) for cracks.
- (2) Weld all cracks found in flywheel housing (1).

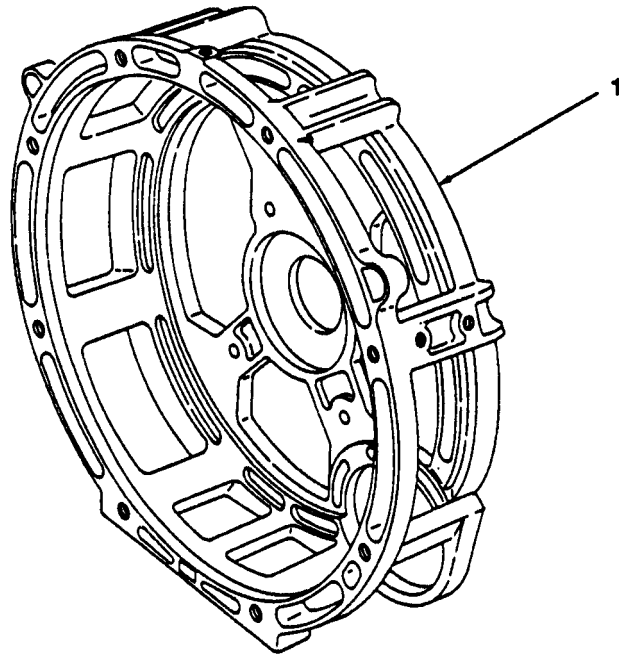

4868-080

Figure 6-2. Flywheel Housing, Repair.

6-9. End Cover.

This task covers: a. Removal b. Repair c. Installation

INITIAL SETUP

<i>Tools</i>	<i>Equipment Condition</i>
General Mechanic's Tool Kit (Item 1, Appendix B)	Rotating magnet removed (para.5-11). Coils removed (para.5-17).
<i>Materials/Parts</i>	Oil pump gears removed (para.5-19). Governor removed (para.4-22). Oil filter head removed (para. 4-42).
Rags, Wiping (Item 7, Appendix B)	
Solvent, Drycleaning (Item 8, Appendix B)	
Gasket, End Cover Mounting (P/N13206E0148)	

a. Removal. (figure 6-3)

- (1) Drain engine oil into suitable container.
- (2) Remove six screws (1), washers (2), and remove end cover (3) and gasket (4).

b. Repair. (figure 6-3)

WARNING

Drycleaning solvent PD-680 used to clean parts is potentially dangerous to personnel and property, Avoid repeated and prolonged skin contact. Do not use near open flame or excessive heat. Flash point of solvent is 100°F-138°F (38°C-60°C).

- (1) Clean end cover with drycleaning solvent and dry thoroughly.
- (2) Inspect end cover for cracks and replace a damaged end cover.
- (3) Inspect front oil seal (5) and crankshaft bearing (6) for wear, and replace all components that are worn or otherwise damaged. Refer to table 6-2 for wear limits.

c. Installation. (figure 6-3)

- (1) Ensure all gasket surfaces are clean and old gasket material is removed.
- (2) Install end cover (3) and new gasket (4) and secure with six screws (1) and washers (2).
- (3) Fill crankcase with engine oil (refer to LO 9-2805-262-12 for proper grade oil).

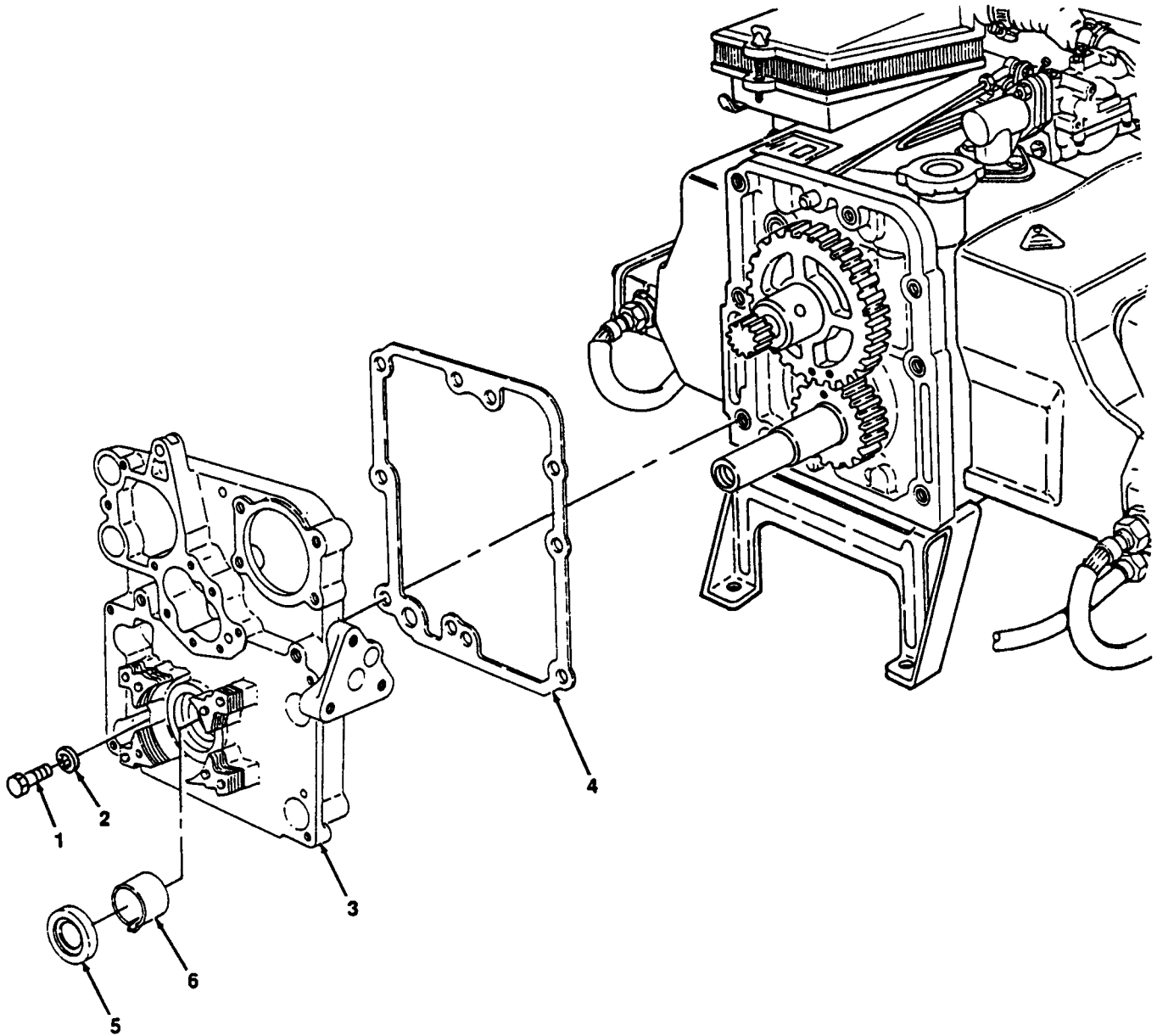

4868-081

Figure 6-3. End Cover, Removal, Repair and Installation.

6-10. Crankshaft Bearing.

This task covers: Replacement

INITIAL SETUP

Tools

General Mechanic's Tool Kit (Item 1, Appendix B)
Arbor Press

Equipment Condition

End cover removed (para.6-9).

Materials/Parts

Rags, Wiping (Item 7, Appendix D)
Solvent, Drycleaning (Item 8, Appendix D)
Bushing, Main Bearing (P/N13206E0137)

Replacement. (figure 6-4)

- (1) Using arbor press, press crankshaft bearing (1) out of end cover (2).

WARNING

Drycleaning solvent, PD-680 used to clean parts is potentially dangerous to personnel and property. Avoid repeated and prolonged skin contact. Do not use near open flame or excessive heat. Flash point of solvent is 100°F–138°F (39°C–60°C).

- (2) Clean crankshaft bearing mounting surfaces.
- (3) Install crankshaft bearing (1) in end cover (2).

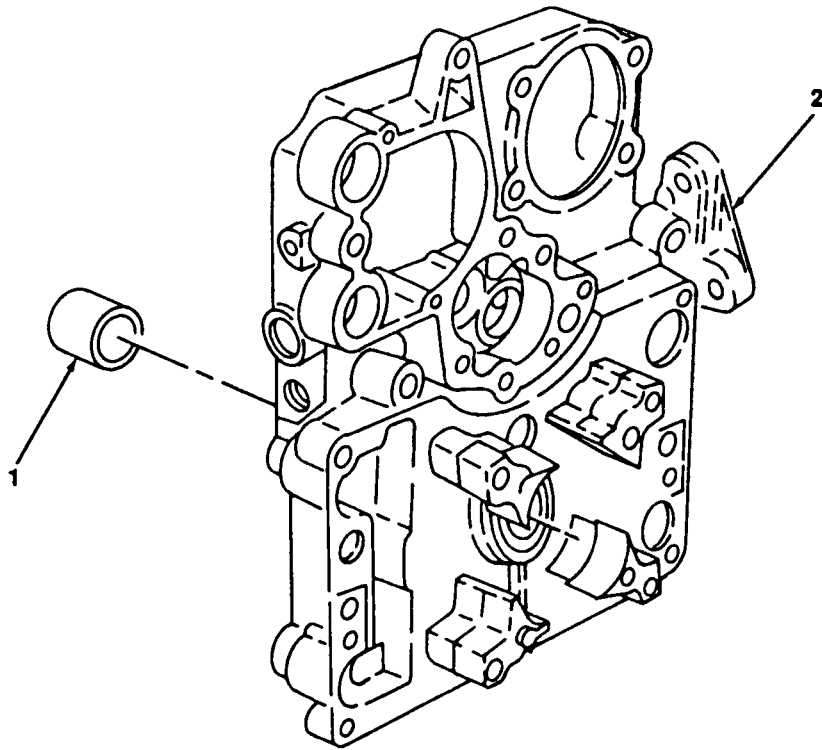

4868-082

Figure 6-4. Crankshaft Bearing, Replacement.

6-11 . End Cover Oil Seal.

This task covers: Replacement

INITIAL SETUP

Tools

General Mechanic's Tool Kit (Item 1, Appendix B)
Arbor Press

Equipment Condition

Rotating magnet removed (para.5-11).
End cover removed (para.6-9).

Materials/Parts

Rags, Wiping (Item 7, Appendix D)
Solvent, Drycleaning (Item 8, Appendix D)
Seal, Oil (P/N13206E0138)

Replacement. (figure6-5)

- (1) Using arbor press, remove oil seal (1) from end cover (2).

WARNING

Drycleaning solvent PD-680 used to clean parts is potentially dangerous to personnel and property. Avoid repeated and prolonged skin contact. Do not use near open flame or excessive heat. Flash point of solvent is 100°F-138°F (38°C-60°C).

- (2) Clean oil seal mounting surfaces with drycleaning solvent, and dry thoroughly.
- (3) Install oil seal (1) in end cover (2).

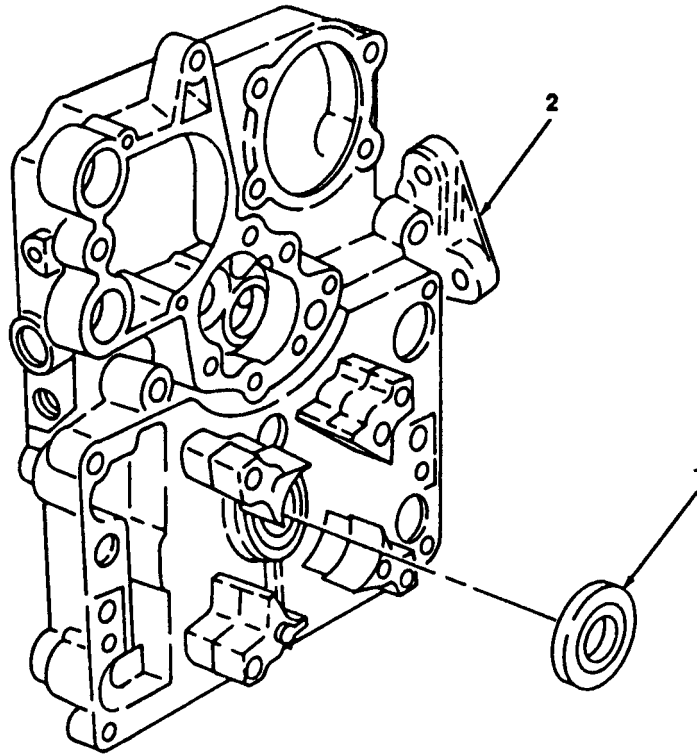

4868-083

Figure 6-5. End Cover Oil Seal, Replacement.

6-12. Camshaft, Camshaft Gear, Valve Tappets and Thrustplate.

This task covers: a. Removal b. Inspection c. Installation

INITIAL SETUP

Tools

General Mechanic's Tool Kit (Item 1, Appendix B)
Kit, Puller (NSN 5120-00-423-1 596) (Item 3,
Appendix B)

Materials/Pads

Rags, Wiping (Item 7, Appendix D)
Solvent, Drycleaning (Item 8, Appendix D)
Washer, Sealing (P/N NAS 1598-4Y)
Gasket, Camshaft Thrust Plate
(NSN 5330-00-867-8771)

Equipment Condition (cont)

Flywheel removed (para.5-23).
Fuel pump removed (para.4-37).
End cover removed (para.6-9).
Oil pan removed (para.5-20).
Rockers removed (para.5-9).
Cylinder head removed (para.5-7).

NOTE

Engine should be upside down for these procedures.

a. Removal. (figure 6-6)

- (1) Remove two screws (1), washers (2), sealing washers (3), and remove thrust plate (4), gasket (5), ball (6), and spring (7).

NOTE

In order to remove camshaft the engine must be upside down to allow the valve tappets to slide away from camshaft.

- (2) Remove camshaft (8) with camshaft gear (9) installed.

NOTE

Note placement of each valve tappet. Valve tappets should be installed in same location they are removed from.

- (3) Remove eight valve tappets (10).
- (4) Remove camshaft gear (9) and key (11) from camshaft (8).

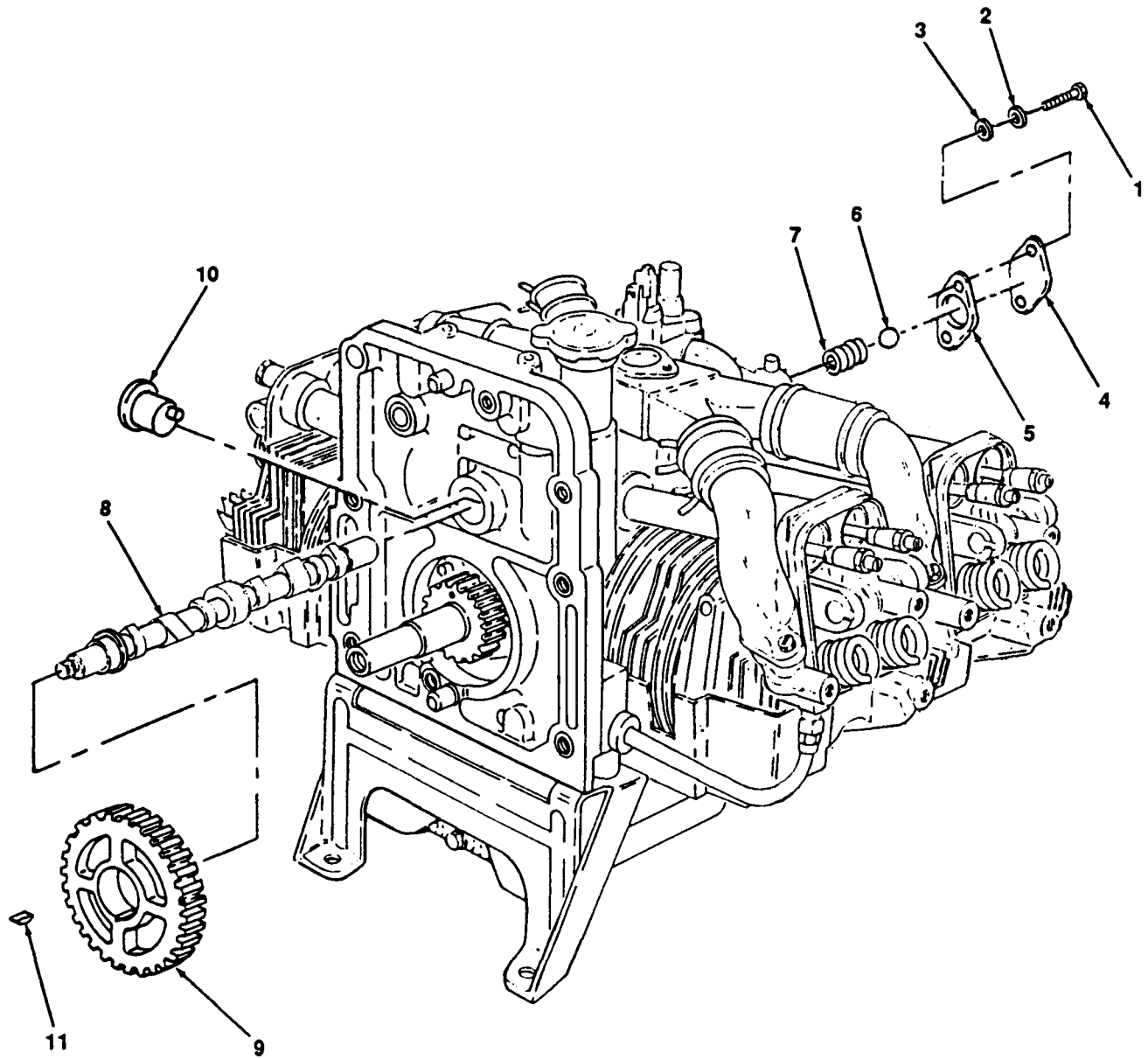

4868-084.1

Figure 6-6. Camshaft, Camshaft Gear, Valve Tappets, and Thrust Plate, Removal and Inspection.

6-12. **Camshaft, Camshaft Gear, Valve Tappets and Thrustplate (cont).**

b. Inspection.

WARNING

Drycleaning solvent PD-680 used to clean parts is potentially dangerous to personnel and property. Avoid repeated and prolonged skin contact. Do not use near open flame or excessive heat. Flash point of solvent is 100°F-138°F (38°C-60°C).

- (1) Clean all items in drycleaning solvent, and dry thoroughly.
- (2) Inspect all items for wear, and replace all items that are worn or otherwise damaged. Refer to table 6-2 for wear limits.

c. Installation. (figure 6-7)

- (1) Install eight valve tappets (10).
- (2) Install camshaft gear (9) and key (11) on camshaft (8).
- (3) Aline timing marks on camshaft gear with mark on crankshaft gear (12).
- (4) Install camshaft (8) and gear (9) assembly.
- (5) Ensure thrust plate gasket mating surfaces are clean and old gasket material is removed.
- (6) Install spring (7), ball (6), thrust plate (4), new gasket (5), and secure with two screws (1), washers (2), and new sealing washers (3).

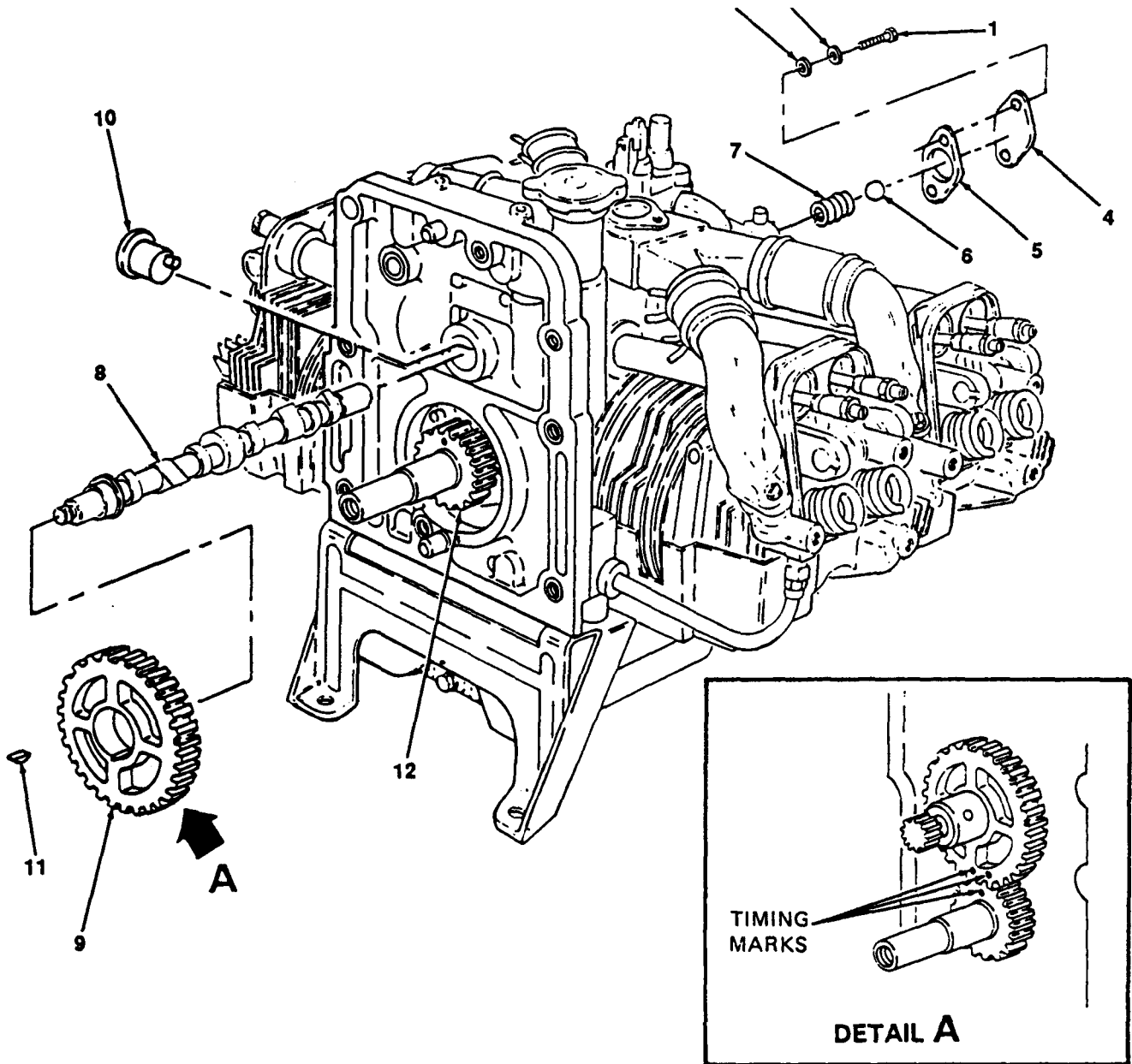

4868-084.2

Figure 6-7. Camshaft, Camshaft Gear, Valve Tappets and Thrust Plate, Installation.

6-13. Crankshaft and Center Main Bearing.

This task covers: a. Removal b. Inspection c. Installation

INITIAL SETUP

Tools

General Mechanic's Tool Kit (Item 1, Appendix B)
Snap Ring Pliers
Wrench, Torque (NSN 6110-00-853-4538) (Item 5, Appendix B)

Materials/Parts

Rags, Wiping (Item 7, Appendix D)
Solvent, Drycleaning (Item 8, Appendix D)

Materials/Parts

Lockwasher, Tab (P/N 9786E113-2)
Screw with Washer Main Bearing
(P/N 13218E0504-70)

Equipment Condition

Oil pan removed (para.5-20).
End cover removed (para.6-9).

NOTE

Engine is upside down for these procedures.

a. Removal. (figure 6-8)

- (1) Bend tangs on lockwasher (1), and remove two bolts (2) and connecting rod bearing cap (3).
- (2) Push piston and connecting rod (4) into top of cylinder (5).
- (3) Repeat steps 1 and 2 for remaining pistons.
- (4) Using suitable snap ring pliers, remove two retaining rings (6).
- (5) Remove camshaft gear (7).
- (6) Remove screw (8) and washer (9) securing center main bearing (10).
- (7) Remove crankshaft (11) with center main bearing (10).
- (8) Remove two screws (12) and washers (13) and remove center main bearing (10).

b. Inspection.

WARNING

Drycleaning solvent PD-680 used to clean parts is potentially dangerous to personnel and property, Avoid repeated and prolonged skin contact. Do not use near open flame or excessive heat. Flash point of solvent is 100°F-138°F (38°C-60°C).

- (1) Clean all items in drycleaning solvent, and dry thoroughly.
- (2) Inspect all items for wear, and replace all items that are worn or otherwise damaged. Refer to table 6-2 for wear limits.

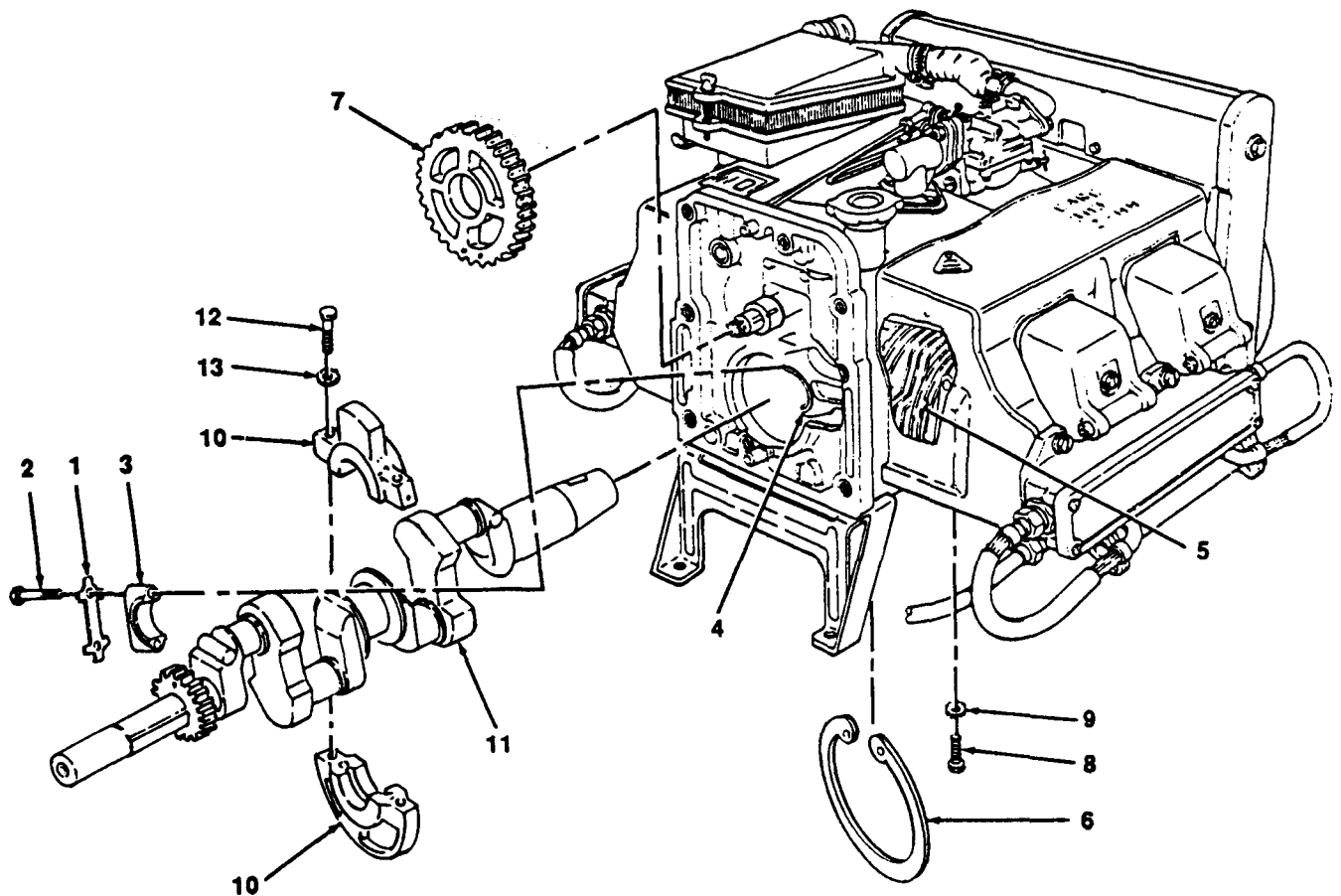

4868-085

Figure 6-8. Crankshaft and Center Main Bearing, Removal.

6-13. **Crankshaft and Center Main Bearing (cont).**

c. Installation. (figure 6-9)

NOTE

Do not reuse lockwashers.

- (1) Install center main bearing halves (10) on crankshaft (11) and secure with two screws (12) and washers (13). Torque bolts to 44-55 in.-lb. (7858-9823 gr cm).
- (2) Install crankshaft (11), align center main bearing (10), and secure with screw (8) and washer (9).
- (3) Install two retaining rings (6) using suitable snap ring pliers.
- (4) Align timing marks on camshaft gear (7) and crankshaft gear (14) and install camshaft gear (7).
- (5) Position connecting rod and piston (4) on crankshaft (11) and install connecting rod bearing cap (3), lockwasher (1) and secure with two bolts (2). Torque bolts to 96-108 in.-lb (11064-12447 gr cm).
- (6) Bend tangs on lockwasher (1).
- (7) Repeat steps 5 and 6 for remaining pistons.

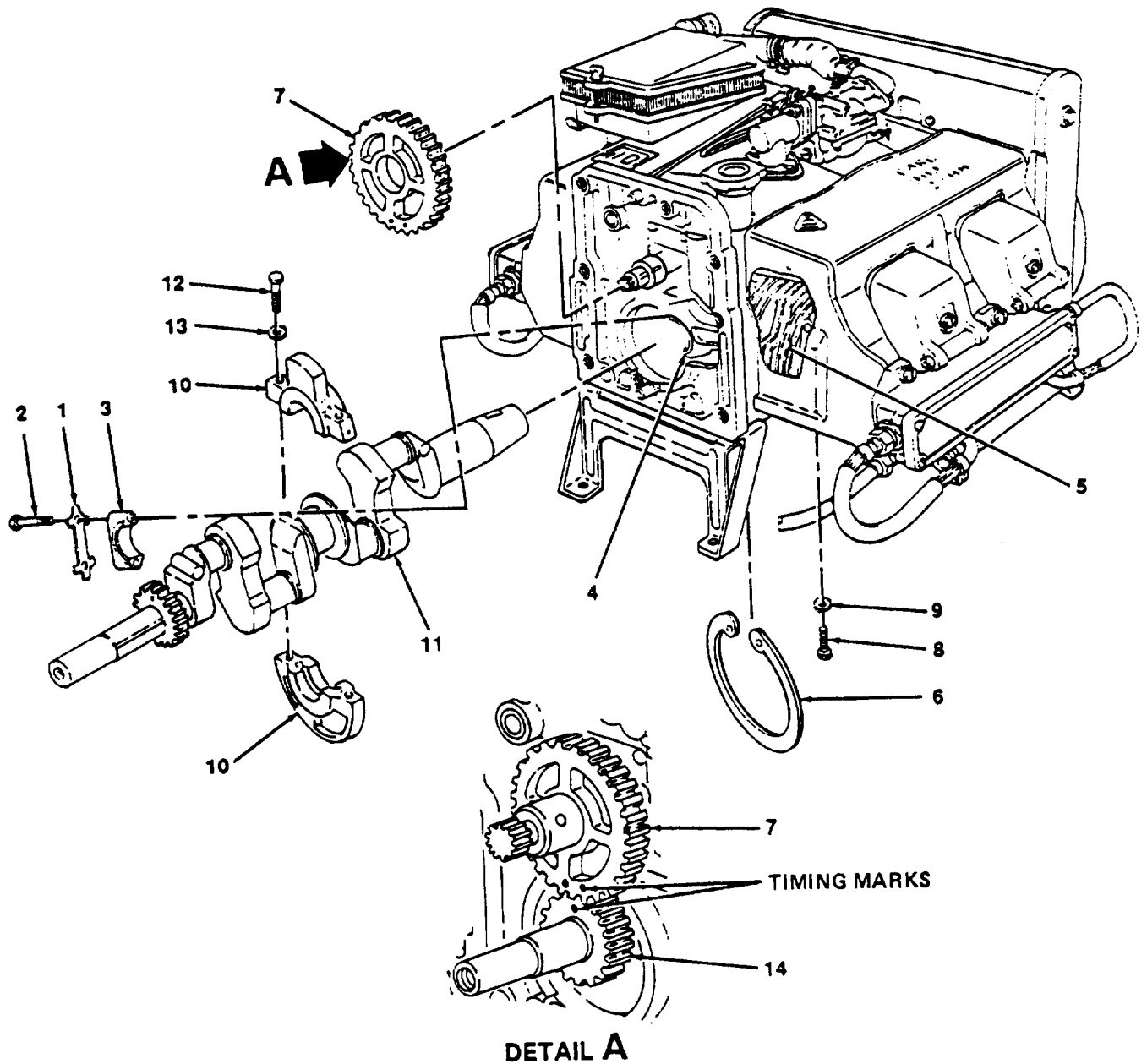

Figure 6-9. Crankshaft and Center Main Bearing, Installation.

4869-086

6-14. Crankcase.

This task covers: Replace

INITIAL SETUP

Tools	Equipment Condition
General Mechanic's Tool Kit (Item 1, Appendix B)	Intake manifold removed (para. 4-38). Cylinder heads removed (para. 5-7). Piston and connecting rod removed (para. 5-22). Camshaft removed (para. 6-12). Crankshaft removed (para. 6-13).
<i>Materials/Parts</i>	
Rags, Wiping (Item 7, Appendix D)	
Solvent, Drycleaning (Item 8, Appendix D)	
Seal Kit (NSN 2805-00-937-0947)	

a.Replace (figure 6-10)

WARNING

Drycleaning solvent PD-680 used to clean parts is potentially dangerous to personnel and property. Avoid repeated and prolonged skin contact. Do not use near open flame or excessive heat. Flash point of solvent is 100°F-138°F (38°C-60°C).

- (1) Clean crankcase (1) with drycleaning solvent and dry thoroughly.
- (2) Inspect crankcase (1) for cracks, and the cylinders (2) for wear, and replace a cracked, worn, or otherwise damaged crankcase. Refer to table 6-2 for wear limits.
- (3) Remove crankshaft bearing (3) and replace.
- (4) Remove breaker point shaft bearing (4) and replace.
- (5) Inspect oil seal (5) and replace if worn or otherwise damaged.
- (6) Inspect flywheel housing mounting studs (6) and (7) and replace if threads are damaged.

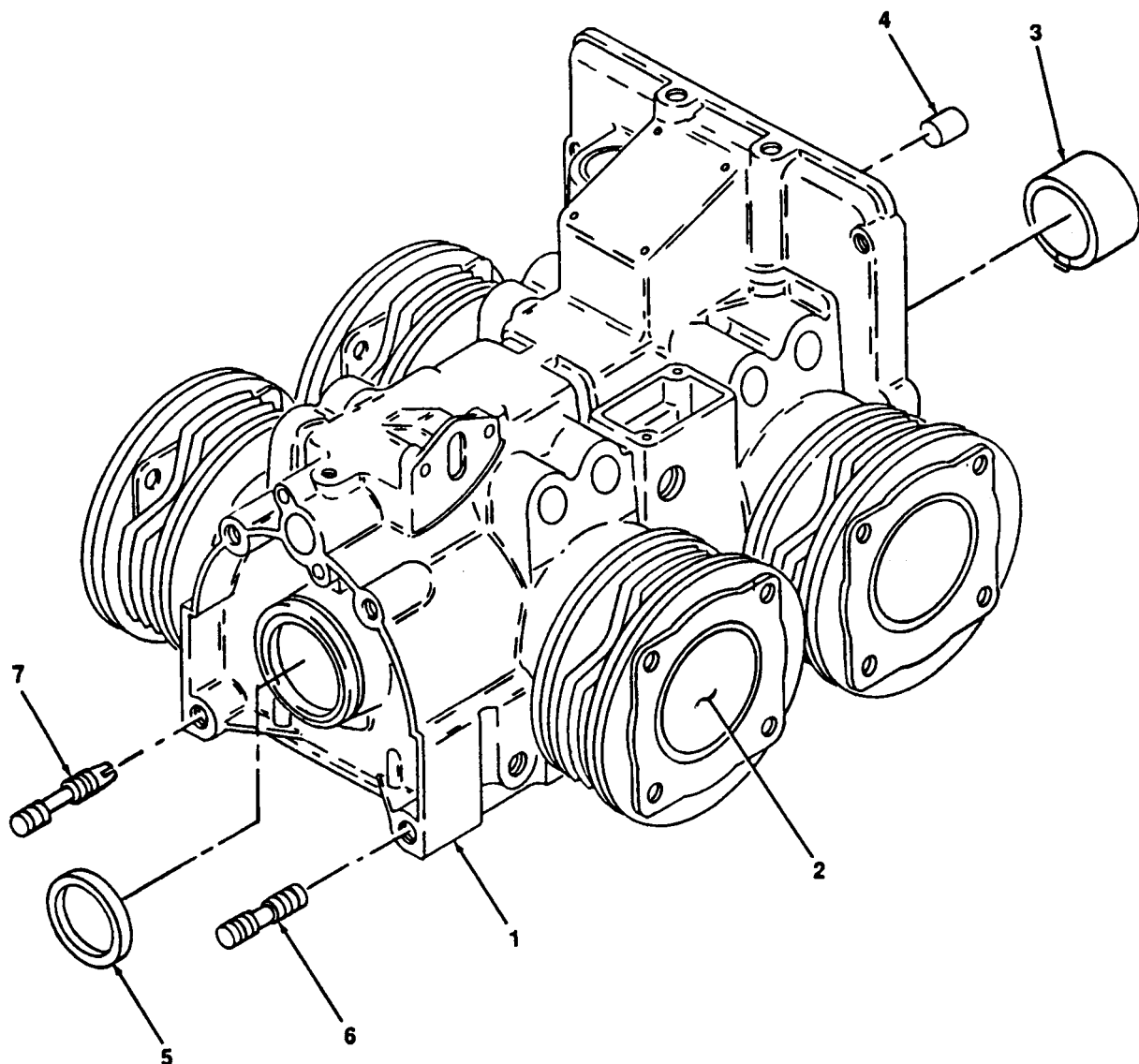

4868-087

Figure 6-10. Crankcase, Replace.

6-15. Crankshaft Rear Bearing.

This task covers: Replacement

INITIAL SETUP

Tools

General Mechanic's Tool Kit (Item 1, Appendix B)
Kit, Puller (NSN 51 20-00-423-1596) (Item 3,
Appendix B)

Equipment Condition

Crankshaft removed (para. 6-13).
Flywheel housing removed (para. 5-24).

Replacement. (figure 6-11)

- (1) Using a puller, remove bearing (1) from crankcase (2).
- (2) Clean bearing mounting surface.
- (3) Install new bearing (1).

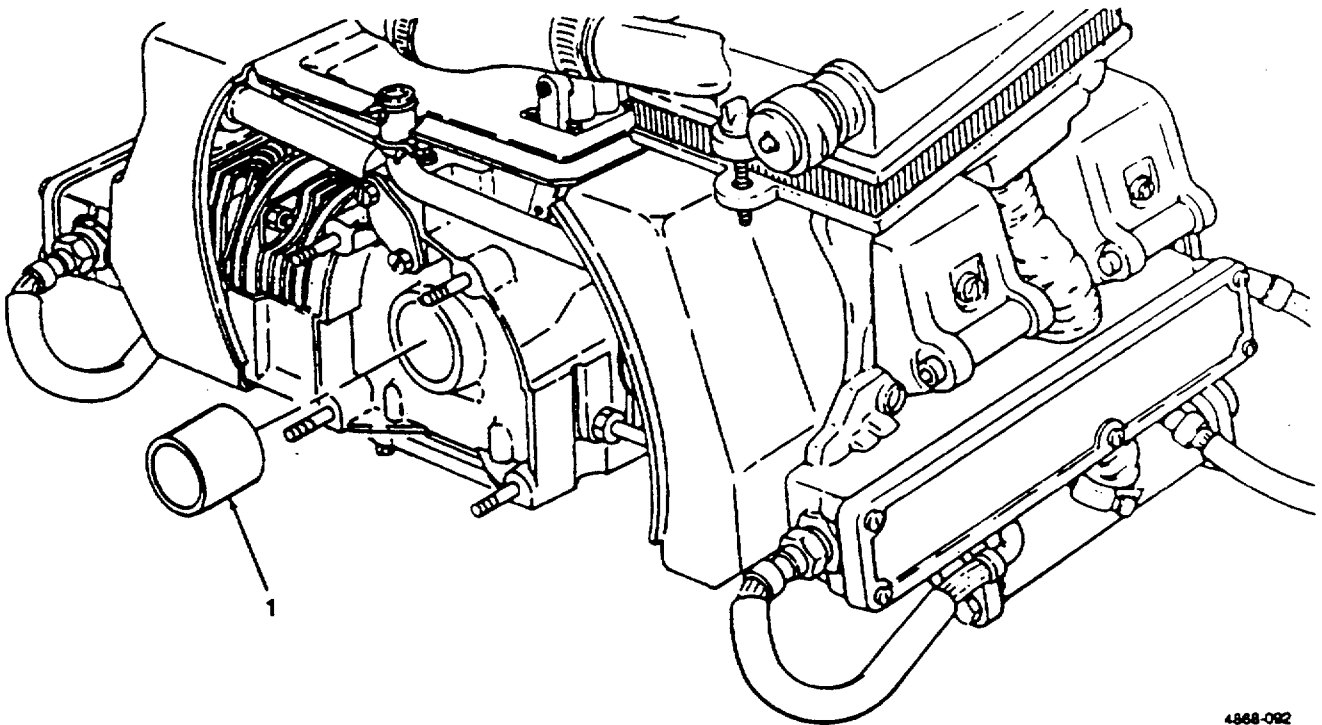

4868-092

Figure 6-11. Crankshaft Rear Bearing, Replacement.

6-16. Deleted

Deleted

Figure 6-12. Crankcase Oil Seal, Replacement.

Change 2 6-25

Table 6-2. Engine Repair and Replacements Limits.

Item	Measurements	
	Maximum*	Minimum*
CAMSHAFT		
Bearing Journal Diameter:		
Front	0.7490 (1.9025)	0.7485 (1.9012)
Center	1.3740 (3.4900)	1.3735 (3.4887)
Rear	0.7490 (1.9025)	0.7485 (1.9012)
Cam Lift	0.1866 (0.4740)	0.1826 (0.4638)
Cam Lobe	1.0616 (2.6965)	1.0576 (2.6863)
Bearing Inside Diameter:		
Front	0.7510 (1.9075)	0.7500 (1.9050)
Center	1.3760 (3.4950)	1.3750 (3.4925)
Rear	0.7510 (1.9075)	0.7500 (1.905)
Clearance Journal to Bearing	0.0025 (0.0063)	0.0010 (0.0025)
CRANKSHAFT		
Main Bearing Journals:		
Front O.D.	0.8750 (2.2225)	0.8745 (2.2212)
Center O.D.	1.2500 (3.175)	1.2495 (3.1737)
Rear O.D.	1.2500 (3.1750)	1.2495 (3.1737)
Out-of-round or taper		
Connecting Rod Journal O.D.	0.8750 (2.2225)	0.8745 (2.2212)
Main Bearings I.D.:		
Front bushing	0.8765 (2.2263)	0.8760 (2.2250)
Center	1.2525 (3.1813)	1.2513 (3.1783)
Rear bushing	1.2515 (3.1788)	1.2510 (3.1775)

Table 6-2. Engine Repair and Replacements Limits (cont).

Item	Measurements	
	Maximum*	Minimum*
Clearances:		
Front main	0.0020 (0.0051)	0.0010 (0.0025)
Center main	0.0030 (0.0076)	0.0013 (0.0033)
Rear main	0.0020 (0.0051)	0.0010 (0.0025)
Connecting rod	0.0053 (0.0135)	0.0039 (0.0099)
End Play	0.0090 (0.0229)	0.0030 (0.0076)
Crankshaft Gear Backlash	0.0040 (0.0102)	0.0020 (0.0051)
Gear O.D.	1.1630 (2.9540)	1.1620 (2.9515)
Gear backlash	0.0070 (0.0178)	0.0030 (0.0076)
CYLINDERS		
Bore diameter	2.2515 (5.7188)	2.2495 (5.7137)
Out-of-round	0.001 TIR (0.0025)	0 000 TIR (0 0000)
Taper 0.0020	0 0000 (0.0051)	(0.0000)
Piston clearance	0.0015 (0.0038)	0.005 (0.0127)
TIMING GEAR		
Backlash	0.0040 (0.0102)	0 0020 (0.0051)

*Measurements in inches(mm).

Change 2 6-27/(6-28 blank)

APPENDIX A

REFERENCES

A-1. **Scope.** This appendix contains all forms, lubrication orders, pamphlets and technical manuals referenced in this manual.

A-2. **Forms.**

Air Force Maintenance Management Policy	AFR 66-1
Air Force Suggestion Program	AFR 900-4
Equipment Inspection and Maintenance Worksheet	DA Form 2404
Recommended Changes to Publications	DA Form 2028 -1, -2
Quality Deficiency Report (QDR)	SF368
Transportation Discrepancy Report(TDR)	SF361
Report of Discrepancy (ROD)	SF364

A-3. **Lubrication Order.**

Lubrication Order, Gasoline Engine, 6 HP Military Standard Models 4A032-I, -2, -3, and -4.....	LO 9-2805-262-12
---	------------------

A-4. **Pamphlets.**

The Army Maintenance Management System (TAMMS)	DA Pam738-750
Consolidated Index of Army Publications and Blank Forms	DA Pam25-30

A-5. **Technical Manuals.**

Unit, Direct Support, General Support and Depot Maintenance Repair Parts and Special Tool List.....	TM 9-2805-262-24P TO 38G2-90-1 NAVFAC-P-8-613E-24P
Preservation, Packaging, and Packing of Military Supplies and Equipment	TM 38-230
Painting Instructions for Army Materiel	TM 43-0139
Procedures for Destruction of Equipment to Prevent Enemy Use	TM 750-244-3 TO 38G2-90-14

A-6. **Field Manual.**

Artificial Respiration	FM 21-11
----------------------------------	----------

A-7. **Technical Bulletin.**

Preservation of Mechanical Equipment for Shipment and Storage	TM 740-97-2
---	-------------

APPENDIX B

MAINTENANCE ALLOCATION CHART

Section I. INTRODUCTION

B-1. Maintenance Allocation Chart (MAC). This MAC assigns maintenance functions in accordance with the Four Level Maintenance Concept.

B-2. Use of the Maintenance Allocation Chart, Section II.

a. The MAC assigns maintenance functions based on the following considerations:

- (1) Skills available.
- (2) Work time required.
- (3) Tools and test equipment required and/or available.

b. If a lower level of maintenance identified in column (4) of the MAC cannot perform all tasks of a single maintenance function (e.g., test, repair), then the higher level that can perform other tasks of that function is also indicated.

c. Higher maintenance levels are automatically authorized to perform maintenance functions assigned to a lower maintenance level.

d. Higher maintenance levels will perform the maintenance functions of lower maintenance levels when required or directed by the Commander who has authority to direct such tasking.

e. Assignment of a maintenance function in the MAC does not carry automatic authorization to carry the related spare or repair parts in stock. Information to requisition or secure parts will be as specified in the associated RPSTL.

f. Normally, there will be no deviation from the assigned level of maintenance. However, in cases of operational necessity, maintenance functions assigned a higher level may, at the request of the lower level, be assigned to the lower level on a one-time basis, if specifically authorized by the maintenance officer of the higher level to which the function is assigned. In such a case, the special tools, equipment, etc., required by the lower level to perform this function will be furnished by the higher level assigned the function. Also, transfer of a function to a lower level does not relieve the higher level of responsibility for the function, so the higher level will provide technical supervision and inspection of the function being performed at the lower level.

B-3. Maintenance Functions. Maintenance functions will be limited to and defined as follows:

a. Inspect. To determine the serviceability of an item by comparing its physical, mechanical, and/or electrical characteristics with established standards through examination (e.g., by sight, sound, or feel).

b. Test. To verify serviceability and detect incipient failure by measuring the mechanical or electrical characteristics of an item and comparing those characteristics with prescribed standards.

c. Service. Operations required periodically to keep an item in proper operating condition, i.e., to clean (includes decontaminate), to preserve, to drain, or to replenish fuel, lubricants, hydraulic fluids, or compressed air supplies.

d. Adjust. To maintain within prescribed limits, by bringing into proper or exact position, or by setting the operating characteristics to the specified parameters.

e. Aline. To adjust specified variable elements of an item to bring about optimum or desired performance.

f. Calibrate. To determine and cause corrections to be made or to be adjusted on instruments or test measuring and diagnostic equipment used in precision measurement. Consists of comparison of two instruments, one of which is a certified standard of known accuracy, to detect and adjust any discrepancy in the accuracy of the instrument being compared.

g. Install. The act of emplacing, seating, or fixing into position an item, part, or module (component assembly) in a manner to allow the proper functioning of an equipment or system.

h. Replace. The act of substituting a serviceable like type part, a subassembly, or module (component or assembly) for an unserviceable counterpart.

i. Repair. The application of maintenance services (inspect test, service, adjust, aline, calibrate, or replace) or other maintenance actions (welding, grinding, riveting, straightening, facing, remachining, or resurfacing) to restore serviceability to an item by correcting specific damage, fault, malfunction, or failure in a part, subassembly, module (component or assembly), end item, or system.

j. Overhaul. That maintenance effort (service/action) necessary to restore an item to a completely serviceable operational condition as prescribed by maintenance standards in appropriate technical publications (i.e., DMWR). Overhaul does not normally return an item to a like new condition.

k. Rebuild. Consists of those services/actions necessary for the restoration of unserviceable equipment to a like new condition in accordance with original manufacturing standards. Rebuild is the highest degree of materiel maintenance applied to Army equipment. The rebuild operation includes the act of returning to zero those age measurements (hours/miles, etc.) considered in classifying Army equipment/components.

B-4. Explanation of Columns in the MAC, Section II.

a. Column (1). Group Number. Column 1 lists functional group code numbers which are assigned to identify maintenance significant components, assemblies, subassemblies, and modules to their next higher assembly.

b. Column (2) Component/Assembly. contains the item names of components, assemblies, subassemblies, and modules for which group numbers (column1) are assigned and for which maintenance is authorized.

c. Column (3). Maintenance Function. Column 3 lists the functions to be performed on items listed in Column 2, (Function definitions are contained in paragraph A-3.)

d. Column (4). Maintenance Level. The maintenance levels, Unit, Direct Support, General Support, and Depot, are allotted separate subcolumns within column 4. Entry of a work time figure (such as 1.0, 0.2) in a subcolumn indicates that that level is authorized to perform the function listed in column 3, and the average time required to do the function is the work time figure. If the number or complexity of tasks within a maintenance function varies from one maintenance level to another, the applicable work time figure for each level will be entered for that function. The work time figure represents the average time it takes to restore a component/assembly to a serviceable condition under a typical field operating environment.

e. Column (5). Tool and Equipment specifies, by code, common tool sets (not individual tools from those sets), common TM DE, and special tools, TM DE, and support equipment required to perform a designated function. The code in Column 5 keys to the listing in Section III of the MAC.

f. Column (6) Remarks This column when applicable, contains a letter code with is keyed to an explanation of the code contained in Section IV of the MAC.

B-5. Explanation of Columns in the MAC, Section III.

a. Column (1). Tool or Test Equipment Reference Code. The tool or test equipment reference code correlates with a code used in the MAC, Section 11, Column 5.

b. Column (2). Maintenance Category. The lowest category of maintenance authorized to use the tool or test equipment.

c. Column(3). Nomenclature. Name or identification of the tool or test equipment.

d. Column (4). National/NATO Stock Number. The National stock number of the tool or test equipment.

e. Column (5). Tool Number. The manufacturer's part number.

B-6. Explanation of Columns in the MAC, Section IV.

a. Column (1). Reference Code The code recorded in column 6, Section II.

b. Column (2). Remarks. This column lists information pertinent to the maintenance function being performed as indicated in the MAC, Section II.

Section II. MAINTENANCE ALLOCATION CHART

(1) Group number	(2) Component/ Assembly	(3) Maintenance function	(4) Maintenance level					(5) Tools and eqpt.	(6) Remarks
			c	o	F	H	D		
00	Engine Assembly	Overhaul					16.0	2	
01	Fuel Filter Assembly	Inspect	0.1					1	
		Service		0.3				1	
		Install		0.1				1	
		Replace		0.2					
02	Air Cleaner Assembly								
	Air Cleaner	Inspect	0.1						
		Service		0.3				1	
		Replace		0.4				1	
	Clamps and Ducts	Inspect	0.1						
		Install		0.2				1	
		Replace		0.3				1	
	Element	Replace		0.2				1	
	Service Indicator	Inspect	0.1						
		Install		0.1				1	
		Replace		0.2				1	
03	Governor and Controls								
	Control Rod Assembly	Inspect	0.1						
		Adjust		0.1				1	
		Install		0.1				1	
		Replace		0.2				1	
		Repair		0.2				1	
	Oil Tube	Inspect	0.1						
		Replace		0.2				1	
	Throttle Control Assembly	Adjust	0.1						
		Install		0.1				1	
		Replace		0.2				1	

Section II. MAINTENANCE ALLOCATION CHART (cont)

(1) Group number	(2) Component/ assembly	(3) Maintenance function	(4) Maintenance level					(5) Tools and eqpt.	(6) Remarks
			C	O	F	H	D		
	Governor	Adjust		0.1				1	
		Install		0.2				1	
		Replace		0.5				1	
04	Carburetor Assembly								
	Fuel Line	Inspect	0.1						
		Install		0.1				1	
		Replace		0.2				1	
	Intake Elbow	Install		0.1				1	
		Replace		0.2				1	
	Carburetor	Inspect		0.1					
		Adjust		0.1				1	
		Install		0.2				1	
		Replace		0.4				1	
	Carburetor Adapter	Inspect		0.1					
		Install		0.1				1	
		Replace		0.2				1	
05	High Tension Cables	Inspect		0.1					
		Test		0.1				2	A
		Install		0.2				1	
		Replace		0.5				1	
06	Spark Plugs	Inspect		0.1					B
		Adjust		0.5				1	
		Install		0.2				1	
		Replace		0.5				1	
07	Exhaust Manifold Assembly								
	Preheater	Install		0.1				1	
		Replace		0.2				1	
	Exhaust Manifold	Install		0.2				1	
		Replace		0.5				1	

Section II. MAINTENANCE ALLOCATION CHART (cont)

(1) Group number	(2) Component/ assembly	(3) Maintenance function	(4) Maintenance level					(5) Tools and eqpt.	(6) Remarks
			C	O	F	H	D		
08	Rocker Cover Assembly								
	Relief Valve	Inspect		0.1					
		Install		0.1				1	
		Replace		0.1				1	
	Rocker Cover	Repair		0.2				1	
		Install		0.1				1	
		Replace		0.2				1	
09	Cooling System								
	Cylinder Head Cover, Internal Cover, and Baffles	Install		0.4				1	
		Replace		0.7				1	
		Repair		0.5				1	
	Winterization Shroud	Install		0.4				1	
		Replace		0.7				1	
		Repair		0.5				1	
	Oil Pan Cover	Install		0.4				1	
		Replace		0.7				1	
		Repair		0.5				1	
	Top Cover	Install		0.4				1	
		Replace		0.7				1	
		Repair		0.5				1	
10	Fuel Pump	Inspect		0.1					
		Test		0.2				1, 2	
		Install		0.4				1	
		Replace		0.7				1	
11	Intake Manifold Assembly								
	Hoses and Clamps	Inspect		0.1					
		Install		0.3				1	
		Replace		0.5				1	

Section II. MAINTENANCE ALLOCATION CHART (cont)

(1) Group number	(2) Component/ assembly	(3) Maintenance function	(4) Maintenance level					(5) Tools and eqpt.	(6) Remarks
			C	O	F	H	D		
	Intake Manifold	Inspect		0.1					
		Install		0.5				1	
		Replace		0.9				1	
	Adapters	Install		0.2				1	
		Replace		0.4				1	
12	Crankcase Ventilation System								
	Breather Box Cover and Breather Tube	Inspect		0.1					
		Install		0.1				1	
		Replace		0.2				1	
13	Oil Filter Assembly								
	Element	Inspect	0.1						
		Install		0.2				1	
		Replace		0.3				1	
	Filter Head	Install		0.3				1	
		Replace		0.5				1	
14	Starter Rope Pulley								
	Starter Rope Pulley	Install		0.1				1	
		Replace		0.2				1	
15	Cylinder Head Assembly								
	Cylinder Head	Test		0.1				1, 3	C
		Inspect		0.2				1	
		Install		0.5				1	
		Replace		0.9				1	
		Repair		1.5				1	
	Rocker	Inspect		0.2				1	
		Install		0.6				1	
		Replace		0.9				1	
		Repair		1.2				1	

Section II. MAINTENANCE ALLOCATION CHART (cont)

(1) Group number	(2) Component/ assembly	(3) Maintenance function	(4) Maintenance level					(5) Tools and eqpt.	(6) Remarks
			C	O	F	H	D		
	Intake and Exhaust Valves	Inspect			0.2			1	
		Adjust			0.5			1	
		Install			1.0			1	
		Replace			1.6			1	
16	Electrical System								
	Breaker Point Cover	Inspect		0.1				1	
		Install		0.1				1	
		Replace		0.1				1	
	Ignition Switch	Test		0.1				1, 2	A
		Install		0.2				1	
		Replace		0.3				1	
	Condensers, Breaker Point Ignition Only	Test		0.1				1, 2	
		Install		0.2				1	
		Replace		0.6				1	
	Coil Cover	Inspect		0.1				1	
		Aline		0.1				1	
		Install		0.2				1	
		Replace		0.4				1	
	Noise Suppression Filters, Breaker Point Ignition Only	Test		0.2				1, 2	A
		Install		0.1				1	
		Replace		0.2				1	
	Rotating Magnet	Install			0.1			1	
		Replace			0.2			1	
	Breaker Points Breaker Point Ignition Only	Inspect		0.1				1	
		Adjust		0.4				1	
		Install		0.3				1	
		Replace		0.6				1	
	Ignition Control Unit, Breakerless Ignition Only	Test			0.4			2, 3	D
		Replace			0.3			2	

Section II. MAINTENANCE ALLOCATIOn CHART (cont)

(1) Group number	(2) Component/ assembly	(3) Maintenance function	(4) Maintenance level					(5) Tools and eqpt.	(6) Remarks
			C	O	F	H	D		
	Transformer Breaker- less Ignition Only	Test			0.1			1, 2	D
		Replace			0.2			1	
	Ignition Module Breakerless Ignition Only	Test			0.1			1, 2	D
		Replace			0.2			1	
	Low Voltage Cable Breakerless Ignition Only	Test			0.1			1, 2	D
		Replace			0.3			1	
	Junction Box Breaker- less Ignition Only	Replace			0.4			1	
	Coil	Test			0.1			1, 2	D
		Replace			0.2			1	
17	Oil Pump Assembly								
	Oil Pump Cover	Inspect			0.2			1	
		Install			0.3			1	
		Replace			0.5			1	
	Oil Pump Gears and Wear Plate	Inspect			0.2			1	
		Install			0.1			1	
		Replace			0.2			1	
	Drain Tube	Install			0.3			1	
		Replace			0.6			1	
18	Oil Pan Assembly								
	Oil Pan and Screen	Inspect			0.1			1	
		Install			0.3			1	
		Replace			0.6			1	

Section II. MAINTENANCE ALLOCATION CHART (cont)

(1) Group number	(2) Component/ assembly	(3) Maintenance function	(4) Maintenance level					(5) Tools and eqpt.	(6) Remarks	
			C	O	F	H	D			
19	Piston and Connecting Rod Assembly	Piston and Rings	Inspect		0.2				1	
		Aline			0.1				1	
		Install			0.1				3	
		Replace			0.3				1	
		Repair			0.5				1	
20	Flywheel	Install			0.3				1	
		Replace			0.5				1	
		Repair				1.0			1	
21	Flywheel Housing and Protective Screen	Install			0.3				1	
		Replace			0.7				1	
		Repair				1.0			1	
22	End Cover	Remove				0.5			1	
		Repair				1.0			1	
		Install				0.5			1	
	Oil Pressure Regulating Valve	Inspect			0.1				1	
		Replace			0.3				1	
	Crankshaft Bearing	Install				0.7			1	
		Replace				1.5			1	
	Oil Seal	Install				0.5			1	
		Replace				0.8			1	
	23	Camshaft and Valve Tappets, Gear and Thrust Plate	Inspect				0.5			1
Install						0.2			1	
Replace						0.4			1	
24	Crankshaft and Main Bearing	Inspect				0.4			1	
		Install				0.2			1	
		Replace				0.4			1	

Section II. MAINTENANCE ALLOCATION CHART (cont)

(1) GROUP NUMBER	(2) COMPONENT/ASSEMBLY	(3) MAINTENANCE FUNCTION	(4) MAINTENANCE LEVEL					(5) TOOLS AND EQUIPMENT	(6) REMARKS
			C	O	F	H	D		
25	Crankcase Assembly								
	Oil Filler Tube and Gage	Inspect Replace	0.1 0.1	0.4				1	E
	Crankshaft Rear Bearing	Replace			0.5		1		
	Crankcase	Replace Repair			0.5 4.0		1		
	Oil Seal	Replace			0.1		1		

**Section III. TOOLS AND TEST EQUIPMENT REQUIREMENTS FOR 6 HP
 MILITARY STANDARD ENGINE**

(1) Tool of test equipment ref code	(2) Maintenance category	(3) NOMENCLATURE	(4) National/NATO stock number	(5) PN Tool number
1	O	General Mechanic's Tool Kit	5180-00-177-7033	
2	F	Shop Equipment, Automotive Maintenance and Repair; Organizational Maintenance No.1 Common, Less Power	4910-00-754-0654	
3	F	Shop Equipment, Automotive Maintenance and Repair; Field Maintenance, Wheeled Vehicles, Set A	4910-95-CL-A02 4910-00-348-7696	
4	O	General Mechanic's Tool Kit	5180-00-699-5273	
5	O	Shop Equipment, Automotive Maintenance and Repair; Organizational Maintenance No 2 Common, Less Power	4910-00-754-6650	

ARMY TM 9-2805-262-14
AIR FORCE TO 38G2-90-1
NAVY NAVFAC P-8-613-14E

Section IV. REMARKS

Reference code	Remarks
A	Test includes continuity test
B	Inspect includes spark test
C	Test includes compression test
D	Test includes resistance test
E	Gage is replaced at unit level maintenance.

APPENDIX C

COMPONENTS OF END ITEM AND BASIC ISSUE ITEMS LISTS

Section I. INTRODUCTION

C-1 . **Scope.**

This appendix lists components of end item and basic issue items for the 6 HP Military Standard Engine to help you inventory items required for safe and efficient operation.

C-2. **General.**

The Components of End Item and Basic Issue Items Lists are divided into the following sections.

a. Section II. Components of End Item This listing is for informational purposes only, and is not authority to requisition replacements. The items are part of the end item, but are removed and separately packaged for transportation or shipment. As part of the end item, these items must be with the end item whenever it is issued or transferred between properly accounts. Illustrations are furnished to assist you in identifying the items.

b. Section III. Basic Issue Items. These are the minimum essential items required to place the 6 HP Military standard engine in operation. The illustrations will assist you with hard-to-identify items. This manual is your authority to request/requisition replacement BII, based on TOE/MTOE authorization of the end item.

C-3. **Explanation of Columns.**

The following provides an explanation of columns found in the tabular listings:

a. Column (1). Illustration Number (Illus Number). This column indicates the number of the illustration in which the item is shown.

b. Column (2). National Stock Number. Indicates the National Stock Number assigned to the item and will be used for requisitioning purposes.

c. Column (3). Description. Indicates the Federal item name, and, if required, a minimum description to identify and locate the item. The last line for each item indicates the FSCM (in parentheses) followed by the part number.

d. Column (4). Unit of Measure. Indicates the measure used in performing the actual operational/maintenance function. This measure is expressed by a two-character alphabetical abbreviation (e.g., ea, in., pr).

e. Column (5). Quantity Required (QTY RQR). Indicates the quantity of the item authorized to be used with/on the equipment.

Section II. COMPONENTS OF END ITEMS

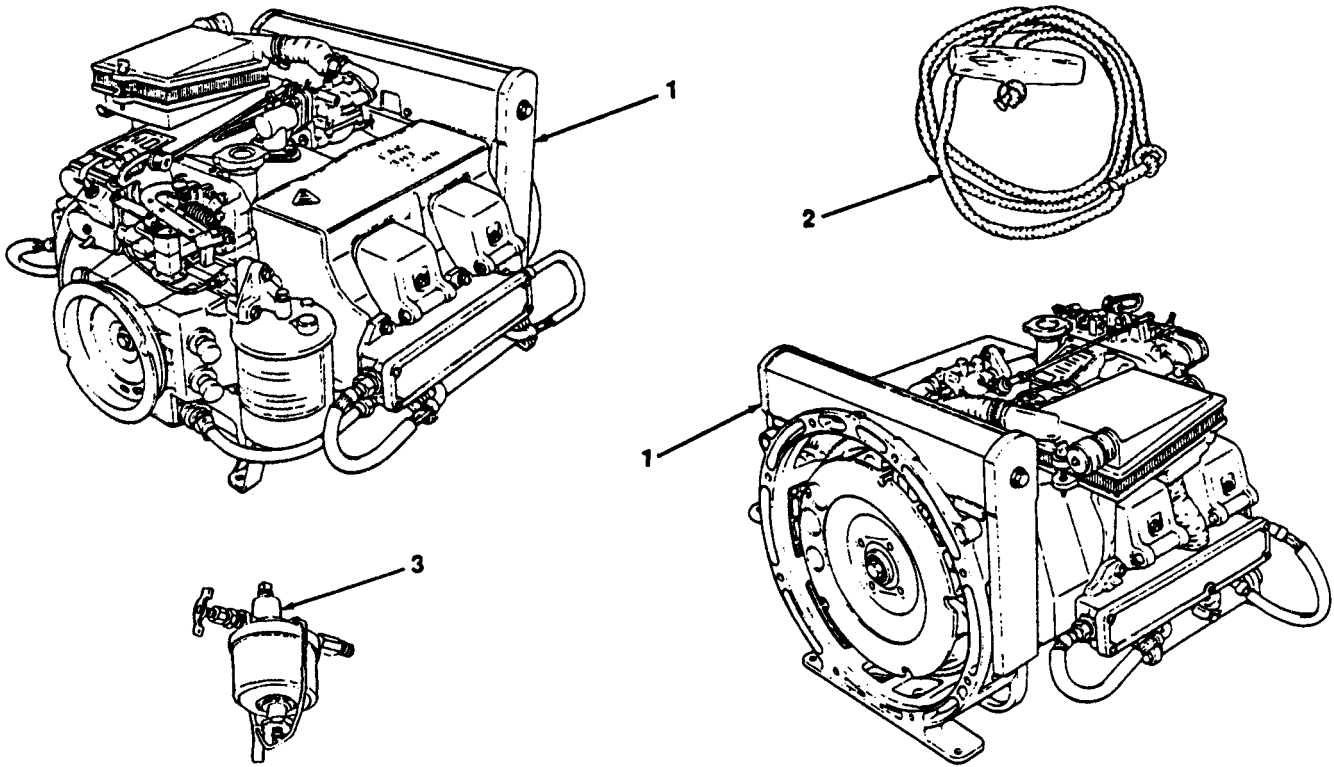

4868-094

(1) Illus Number	(2) National Stock Number	Description FSCM and Part Number	(3)	Usable On Code	(4) U/M	(5) Qty Rqr
1	2805-00-776-0483	Engine, Military Standard 6 HP Model 4A032-1			ea	1
1	2805-00-068-7512	Engine, Military Standard 6 HP Model 4A032-2			ea	1
1	2805-01-139-0596	Engine, Military Standard			ea	1
1	2805-01-276-5944	Engine, Military Standard 6 HP Model 4A032-4			ea	1
2	2990-00-972-7950	Rope, Starter Cable Assembly			ea	1
3	2910-00-905-9792	Filter Assembly, Fuel			ea	1

Section III. BASIC ISSUE ITEMS

Not Applicable

APPENDIX D

EXPENDABLE/DURABLE SUPPLIES MATERIALS LIST

Section I. INTRODUCTION

D-1. **Scope.** This listing is for informational purposes only and is not authority to requisition the listed items. These items are authorized to you by CTA 50-970, Expendable/Durable Items (except medical, class V, repair parts, and heraldic items).

D-2. Explanation of Columns.

a. Column (1)- Item Number. This number is assigned to the entry in the listing and is referenced in the narrative instructions to identify the material (e.g., "Use cleaning compound, item 5, appendix C").

b. Column (2)-Level. This column identifies the lowest level of maintenance that requires the listed item.

- C - Operator/Crew
- O - Organizational Maintenance
- F - Direct Support Maintenance
- H - General Support Maintenance

c. Column (3) - National Stock Number. This is the National stock number assigned to the item; use it to request or requisition the item.

d. Column (4)-Description. Indicates the Federal item name, and, if required, a description to identify the item. The last line for each item indicates the Federal Supply code for Manufacturer (FSCM) in parentheses followed by the part number.

d. Column (5)- Unit of Measure (U/M). Indicates the measure used in performing the actual maintenance function. This measure is expressed by a two-character alphabetical abbreviation (e.g., EA, IN., PR). If the unit of measure differs from the unit of issue, requisition the lowest unit of issue that will satisfy your requirements.

Section II. EXPENDABLE/DURABLE SUPPLIES AND MATERIALS LIST

(1) Item number	(2) Level	(3) National stock number	(4) Description	(5) U/M
1	C	7930-00-282-9699	Detergent	gal.
2	C	8010-01-229-7546	Coating, Chemical Agent Resistant (Green)	qt.
3	C	9150-01-152-4117	Oil, Engine, OE/HDO 15W-40	qt.
		9150-01-152-4118	Oil, Engine, OE/HDO 15W-40	5 gal.
		9150-01-152-4119	Oil, Engine, OE/HDO 15W-40	55 gal.
4	C	9550-00-183-7808	Oil, Engine OE/HDO 30	qt.
5	C		Oil, Engine, OEA/APH-PD-1 (Obsolete use Item 6)	qt.
6	C	9150-00-402-4478	Oil, Engine OEA/APG-PD-1	qt.
7	C	7920-00-205-1711	Rag, Wiping, 50/B (58536) A-A-531	ea
8	C	6850-00-664-5685	Solvent, Drycleaning, PD-680	qt.

APPENDIX E

TORQUE LIMITS

E-1. General. Table E-1 provides torque limits to be observed when installing attaching hardware or spark plugs.

Table E-1. Torque Limits.

Attaching Part	Range
Flywheel bolt	37-40 ft lb (78585-85729 gr cm)
Cylinder head nuts	22-24 ft lb (47151-51437 gr cm)
Rocker arm adjusting screw lock nuts	44-55 in. lb (7858-9823 gr cm)
Intake manifold to cylinder head bolts	45-50 in. lb (8037-8930 gr cm)
Exhaust manifold to cylinder head bolts	60-65 in. lb (10715-1 1609 gr cm)
Spark plugs	23-25 ft lb (49115-53580 gr cm)
Connecting rod bolts	96-108 in. lb (17145-19289 gr cm)
Oil pan screws	25-30 in. lb (4465-5358 gr cm)
Fuel pump bolts	55-65 in. lb (9823-11609 gr cm)
Carburetor mounting bolts	60-85 in. lb (10716-15181 gr cm)
Oil filter shell screw	70-80 in. lb (8021-9266 gr cm)
Center main bearing screws	44-55 in. lb (7858-9823 gr cm)
Starter rope pulley bolt	108-120 in. lb (19289-21432 gr cm)
End cover screws	45-50 in. lb (8037-8930 gr cm)

**APPENDIX F
ADDITIONAL AUTHORIZATION LIST (AAL)**

Section I. INTRODUCTION

D-1. SCOPE. This appendix lists additional items you are authorized for the Engine, Gasoline, 6 HP MILSTD.

D-2. GENERAL. Section II identifies items that are not routinely used with the MILSTD and do not have to accompany it or be turned in with it.

D-3. EXPLANATION OF LISTING. National stock numbers, descriptions, and quantities are provided to help you identify and request the additional items you require to support this equipment. The items are listed in alphabetical sequence by item name.

Section II. ADDITIONAL AUTHORIZATION LIST

(1) ITEM NUMBER	(2) NATIONAL STOCK NUMBER	(3) DESCRIPTION, (FSCM) and Part Number	Usable On Code	(4) U/M	(5) QTY AUTH
1	2990-01-032-0775	SPARK ARRESTER		EA	1

INDEX

Subject	Paragraph
A	
Administrative Storage	4-53
Air Cleaner Assembly	4-14
Air Cleaner Element	4-16
Air intake Elbow	4-24
Altitudes, Operation at Different	2-14
B	
Breaker Points (Breaker Point Ignition)	4-49
Breaker Point Cover	4-44
Breather Box Cover and Breather Tube	4-40
C	
Camshaft, Camshaft Gear, Valve Tappets, Thrust Plate	6-12
Capabilities and Features, Equipment Characteristics	1-8
Carburetor	4-25
Carburetor Adapter	4-26
Clamps and Ducts	4-15
Coil	5-17
Coil Cover	4-47
Common Tools and Test Equipment	
Direct Support	5-1
General Support	6-1
Unit	4-1
Components of End Item and Basic Issue Items List	C-1
Condenser (Breather Point Ignition)	4-46
Connecting Rod Assembly, Piston and	5-22
Consolidated Index of Army Publications and Blank Forms	1-2
Controls and Indicators, Operator's	2-2
Crankcase	6-14
Crankcase Oil Seal	5-27
Crankshaft Bearing	6-10
Crankshaft and Center Main Bearing	6-13
Crankshaft Rear Bearing	6-15
Cylinder Head Assembly	5-27
Cylinder Head Cover, Internal Cover and Baffles	4-34
D	
Destruction of Army Material to Prevent Enemy Use	1-5
Differences Between Models	1-12

INDEX (cont)

Subject	Paragraph
D (cont)	
Direct Support Maintenance Procedures	
Coil	5-17
Cylinder Head Assembly	5-7
Drain Tube	5-21
Flywheel	5-23
Flywheel Housing and Protective Screen	5-24
Ignition Control Unit(Breakerless Ignition)	5-12
Ignition Module (Breakerless Ignition)	5-14
Intake and Exhaust Valves	5-10
Junction Box(Breakerless Ignition).	5-15
Low Voltage Cable(Breakerless Ignition)	5-16
Oil Filler Tube and Gage	5-26
Oil Pan and Screen	5-20
Oil Pressure Regulating Valve Assembly	5-25
Oil Pump Cover	5-18
Oil Pump Gears and Wear Plate	5-19
Piston and Connecting Rod Assembly	5-22
Rockers	5-9
Rotating Magnet	5-1 1
Transformer(Breakerless Ignition)	5-13
Valves	5-8
Direct Support Troubleshooting Procedures	5-5
Drain Tube	5-21
Ducts, Clamps and	4-15
Dusty or Sandy Areas, Operation in	2-11

E

Element, Air Cleaner	4-16
End Cover	6-9
End Cover Oil Seal	6-11
Equipment Characteristics,Capabilities and Features	1-8
Equipment Data	1-11
Equipment Improvement Recommendations (EIR), Reporting	1-4
Exhaust Manifold	4-30
Exhaust Valves, Intake and	5-10
Expendable/Durable Supplies Materials List	D-1
Extreme Cold, Operationin	2-15
Extreme Heat, Operationin	2-13

INDEX (cont)

F

Filter, Noise Suppression	4-48
Flywheel15-23,	6-7
Flywheel Housing	6-8
Flywheel Housing and Protective Screen	5-24
Fuel Filter Assembly	4-13
Fuel Line	4-23
Fuel Pump	4-37

G

Gage, Oil Filler Tube and	5-26
General Support Maintenance Procedures	
Camshaft, Camshaft Gear, Valve Tappets and Thrust Plate	6-12
Crankcase	6-14
Crankcase Oil Seal	6-16
Crankshaft and Center Main Bearing	6-13
Crankshaft Bearing	6-10
Crankshaft Rear Bearing	6-15
End Cover	6-9
End Cover Oil Seal	6-11
Flywheel	6-7
Flywheel Housing	6-8
General Support Troubleshooting Procedures	6-5
Glossary	1-7
Governor	4-21
Governor Assembly	4-22
Governor Control Rod	4-18

H

Handling, Safety, Care, and	1-13
High Tension Cables	4-27

I

Ignition Control Unit(Breakerless Ignition)	5-12
Ignition Module (Breakerless Ignition)	5-14
Ignition Timing (Breaker Point Ignition)	4-50
Ignition Switch	4-45
Indictors, Operator's Controls and	2-2
Inspection	4-4
Intake and Exhaust Valves	5-10
Intake Manifold Adapters	4-39

INDEX (cont)

Subject	Paragraph
I (cont)	
Intake Manifold and Intake Manifold Hoses and Clamps	4-38
Intermediate Storage Procedures, Short Term and	4-52
J	
Junction Box (Breakerless Ignition)	5-15
K	
L	
Location and Description of Major Components (Models 4A032-1,-2)	1-9
Location and Description of Major Components (Models 4A032-3,-4)	1-10
Low Voltage Cable (Breakerless Ignition)	5-16
Lubrication 3-2,	4-5
M	
Magnet, Rotating	5-11
Maintenance Allocation Chart	B-1
Maintenance Forms, Records and Reports	1-3
Maintenance Procedures, Direct Support	
Coil	5-17
Cylinder Head Assembly	5-7
Drain Tube	5-21
Flywheel	5-23
Flywheel Housing and Protective Screen	5-24
Ignition Control Unit (Breakerless Ignition)	5-12
Ignition Module (Breakerless Ignition)	5-14
Intake and Exhaust Valves	5-10
Junction Box (Breakerless Ignition)	5-15
Low Voltage Cable (Breakerless Ignition)	5-16
Oil Filler Tube and Gage	5-26
Oil Pan and Screen	5-20
Oil Pressure Regulating Valve Assembly	5-25
Oil Pump Cover	5-18
Oil Pump Gears and Wear Plate	5-19
Piston and Connecting Rod Assembly	5-22
Rocker Arms	5-9
Rotating Magnet	5-11

INDEX (cont)

Subject	Paragraph
M (cont)	
Transformer (Breakerless Ignition)	5-13
Valves	5-8
Maintenance Procedures, General Support	
Camshaft, Camshaft Gear, Valve Tappets and Thrust Plate	6-12
Crankcase	6-14
Crankcase Oil Seal	6-16
Crankshaft and Center Main Bearing	6-13
Crankshaft Bearing	6-10
Crankshaft Rear Bearing	6-15
End Cover	6-9
End Cover Oil Seal	6-11
Flywheel	6-7
Flywheel Housing	6-8
Maintenance Procedures, Unit	
Air Cleaner Assembly	4-14
Air Cleaner Element	4-16
Air Intake Elbow	4-24
Breaker Points (Breaker Point Ignition)	4-49
Breaker Point Cover	4-44
Breather Box Cover and Breather Tube	4-40
Carburetor	4-25
Carburetor Adapter	4-26
Clamps and Ducts	4-15
Coil Cover	4-47
Condenser (Breaker Point Ignition)	4-46
Cylinder Head Cover, Internal Cover and Baffles	4-34
Exhaust Manifold	4-30
Fuel Filter Assembly	4-13
Fuel Line	4-23
Fuel Pump	4-37
Governor	4-21
Governor Assembly	4-22
Governor Control Rod	4-18
High Tension Cables	4-27
Ignition Switch	4-45
Ignition Timing	4-50
Intake Manifold Adapters	4-39
Intake Manifold and Intake Manifold Hoses and Clamps	4-38
Noise Suppression Filters (Breaker Point Ignition)	4-48
Oil Filter	4-41
Oil Filter Head	4-42
Oil Pan Cover	4-35
Oil Tube	4-19
Painting	4-12

Subject	Paragraph
M (cont)	
Preheater	4-29
Relief Valve	4-31
Rocker Box Cover.....	4-32
Service Indicator	4-17
Spark Plugs	4-28
Starter Rope Pulley	4-43
Throttle Control Assembly	4-20
Top Cover	4-36
Winterization Shroud	4-33
Major Components(Mode14A032-1,-2), Location and Description of	1-9
Major Components (Mode14A032-3, -4), Location and Description of	1-10
Manifold, Exhaust	4-30
Manifold Adapters, Intake.....	4-39
Models, Differences Between	1-12
Module(Breakerless Ignition), Ignition	5-14
N	
Noise Suppression Filter(Breaker Point Ignition)	4-48
O	
Oil Filter Tube and Gage	5-26
Oil Filter	4-41
Oil Filter Head	4-42
Oil Pan and Screen	5-20
Oil Pan Cover	4-35
Oil Pressure Regulating Valve Assembly	5-25
Oil Pump Cover	5-18
Oil Pump Gears and Wear Plate	5-19
Oil Tube	4-19
Operational Different Altitudes.	2-14
Operation in Dusty or Sandy Areas	2-11
Operationin Extreme Cold	2-15
Operation in Extreme Heat	2-13
Operation, Principles of	1-14
Operation in Rainy, Humid, or Salt Air Conditions	2-12
Operator's Controls and indicators	2-2
Operator Troubleshooting Procedures	3-4

INDEX (cont)

Subject	Paragraph
P	
Painting	4-12
Pan,Oil	5-20
Piston and Connecting Rod Assembly	5-22
Preheater	4-29
Preparation for Storage or Shipment	1-6
Preventive Maintenance Checks and Services (PMCS)	
Operator	2-3
Unit	4-8
Principles of Operation	1-14
Procedures, Starting	2-9
Procedures, Stopping	2-10
Pump, Fuel	4-37
Purpose of PMCS Tables	2-4
Q	
R	
Rainy, Humid, or Salt air Conditions, Operation in	2-12
Records and Reports, Maintenance Forms	1-3
References	A-1
Relief Valve	4-31
Repair Parts	
Direct Support	5-3
General Support	6-3
Unit	4-3
Reporting Equipment Improvement Recommendations (EAR)	1-4
Rocker Box Cover	4-32
Rockers	5-9
Rotating Magnet	5-11
S	
Safety, Care and Handling	1-13
Salt Air Conditions, Operation in Rainy, Humid or	2-12
Sandy or Dusty Areas,Operation in	2-11
Short Term and Intermediate Storage Procedures	4-52
Service Indicator	4-17
Spark Plugs	4-28
Special Tools, Test Measurement and Diagnostic Equipment (TMDE) and Support Equipment 4-2,5-2,	6-2
Starter Rope Pulley	4-43
Starting Procedures	2-9
Stopping Procedures	2-10
Storage, Administrative	4-53
Storage or Shipment, Preparation for	1-6

Subject	Paragraph
S (cont)	
Support Equipment, Special Tools, Test Measurement and Diagnostic Equipment, and	4-2,5-2,6-2
Switch, Ignition	4-45

T

Testing	4-6
Throttle Control Assembly	4-20
Timing (Breaker Point Ignition), Ignition	4-50
Top Cover	4-36
Torque Limits	E-1
Transformer(Breakerless Ignition)	5-13
Troubleshooting,Procedures,	
Direct Support	5-5
General Support	6-5
Operator	3-4
Unit	4-10

U

Unit Maintenance Procedures	
Air Cleaner Assembly	4-14
Air Cleaner Element	4-16
Air Intake Elbow	4-24
Breaker Points(Breaker Point Ignition)	4-49
Breaker Point Cover	4-44
Breather Box Cover and Breather Tube	4-40
Carburetor	4-25
Carburetor Adapter	4-26
Clamps and Ducts	4-15
Coil Cover	4-47
Condenser(BreakerPoint Ignition)	4-46
Cylinder Head Cover, Internal Cover and Baffles	4-34
Exhaust Manifold	4-30
Fuel Filter Assembly	4-13
Fuel Line	4-23
Fuel Pump	4-37
Governor	4-21
Governor Assembly	4-22
Governor Control Rod	4-18
High Tension Cables	4-27
Ignition Switch	4-45
IgnitionTiming(BreakerPoint Ignition)	4-50

U (cont)

Intake Manifold	4-39
Intake Manifold and IntakeManifold Hoses and Clamps	4-38
Noise Suppression Filters(Breaker Point Ignition)	4-48
Oil Filter	4-41
Oil Filter Head	4-42
Oil Pan Cover	4-35
Oil Tube	4-19
Painting	4-12
Preheater	4-29
Relief Valve	4-31
Rocker Box Cover	4-32
Service Indicator	4-17
Spark Plugs	4-28
Starter Rope Pulley	4-43
Throttle Control Assembly	4-20
Top Cover	4-36
Winterization Shroud	4-33
Unit Troubleshooting Procedures	4-10

V

Valves	5-8
Valve, Relief	4-31

Winterization Shroud	4-33
--------------------------------	------

X, Y, Z

By Order of the Secretary of the Army, Air Force, and Navy:

GORDON R. SULLIVAN
General, United States Army
Chief of Staff

Official:

PATRICIA P. HICKERSON
Brigadier General, United States Army
The Adjutant General

MERRILL A. McPEAK,
General USAF
Chief of Staff

Official:

CHARLES C. McDONALD
General, USAF
Commander, Air Force Logistics Command

DAVID E. BOTTORFF
Rear Admiral, CEC, US Navy
Commander
Navy Facilities Engineering Command

Distribution:

To be distributed in accordance with DA Form 12-25E, (qty rqr block no. 0766)

RECOMMENDED CHANGES TO EQUIPMENT TECHNICAL PUBLICATIONS

SOMETHING WRONG WITH THIS PUBLICATION?



THEN... JOT DOWN THE DOPE ABOUT IT ON THIS FORM. CAREFULLY TEAR IT OUT, FOLD IT AND DROP IT IN THE MAIL!

FROM: (PRINT YOUR UNIT'S COMPLETE ADDRESS)
PFC JOHN DOE
COA, 3d ENGINEER BN
FT. LEONARD WOOD, MO 63108
 DATE SENT

PUBLICATION NUMBER: **TM 9-2805-262-14**
 PUBLICATION DATE: **30 Sep. 1991**
 PUBLICATION TITLE: **Engine, Gasoline, 6 hp, Military Standard Models**

BE EXACT. PIN-POINT WHERE IT IS

PAGE NO	PARA-GRAPH	FIGURE NO	TABLE NO
---------	------------	-----------	----------

6

**2-1
a**

IN THIS SPACE TELL WHAT IS WRONG AND WHAT SHOULD BE DONE ABOUT IT:

In line 6 of paragraph 2-1a the manual states the engine has 6 Cylinders. The engine on my set only has 4 Cylinders. Change the manual to show 4 Cylinders.

B1

4-3

Callout 16 on figure 4-3 is pointing at a bolt. In key to figure 4-3, item 16 is called a shim - Please correct one or the other.

125

line 20

I ordered a gasket, item 19 on figure B-16 by NSN 2 910-00-762-3001. I got a gasket but it doesn't fit. Supply says I got what I ordered, so the NSN is wrong. Please give me a good NSN

PRINTED NAME, GRADE OR TITLE, AND TELEPHONE NUMBER

JOHN DOE, PFC (268) 317-7111

SIGN HERE

JOHN DOE

DA FORM 2028-2
1 JUL 79

PREVIOUS EDITIONS ARE OBSOLETE.
DRSTS-M Overprint 1, 1 Nov 80

P.S.--IF YOUR OUTFIT WANTS TO KNOW ABOUT YOUR RECOMMENDATION MAKE A CARBON COPY OF THIS AND GIVE IT TO YOUR HEADQUARTERS

TEAR ALONG PERFORATED LINE

FILL IN YOUR
UNIT'S ADDRESS
↓

FOLD BACK

DEPARTMENT OF THE ARMY

OFFICIAL BUSINESS

COMMANDER
U.S. ARMY TROOP SUPPORT COMMAND
ATTN: AMSTR-MMTS
4300 GOODFELLOW BOULEVARD
ST. LOUIS, MO 63120-1798

TEAR ALONG PERFORATED LINE

RECOMMENDED CHANGES TO EQUIPMENT TECHNICAL PUBLICATIONS

SOMETHING WRONG WITH THIS PUBLICATION?



THEN... JOT DOWN THE DOPE ABOUT IT ON THIS FORM. CAREFULLY TEAR IT OUT. FOLD IT AND DROP IT IN THE MAIL!

FROM: (PRINT YOUR UNIT'S COMPLETE ADDRESS)

DATE SENT

PUBLICATION NUMBER

TM 9-2805-262-14

PUBLICATION DATE

30 Sep. 1991

PUBLICATION TITLE

Engine, Gasoline, 6 hp,
Military Standard Models

BE EXACT PIN-POINT WHERE IT IS

PAGE NO	PARA-GRAPH	FIGURE NO	TABLE NO

IN THIS SPACE TELL WHAT IS WRONG AND WHAT SHOULD BE DONE ABOUT IT:

TEAR ALONG PERFORATED LINE

PRINTED NAME, GRADE OR TITLE AND TELEPHONE NUMBER

SIGN HERE

DA FORM 2028-2
1 JUL 79

PREVIOUS EDITIONS ARE OBSOLETE.
DRSTS-M Overprint 2, 1 Nov 80.

PS...IF YOUR OUTFIT WANTS TO KNOW ABOUT YOUR RECOMMENDATION MAKE A CARBON COPY OF THIS AND GIVE IT TO YOUR HEADQUARTERS.

FILL IN YOUR
UNIT'S ADDRESS



FOLD BACK

DEPARTMENT OF THE ARMY



OFFICIAL BUSINESS

COMMANDER
U.S. ARMY TROOP SUPPORT COMMAND
ATTN: AMSTR-MMTS
4300 GOODFELLOW BOULEVARD
ST. LOUIS, MO 63120-1798

TEAR ALONG PERFORATED LINE

TEAR ALONG PERFORATED LINE

FILL IN YOUR
UNIT'S ADDRESS



FOLD BACK

DEPARTMENT OF THE ARMY

OFFICIAL BUSINESS

COMMANDER
U.S. ARMY TROOP SUPPORT COMMAND
ATTN: AMSTR-MMTS
4300 GOODFELLOW BOULEVARD
ST. LOUIS, MO 63120-1798

FILL IN YOUR
UNIT'S ADDRESS



FOLD BACK

DEPARTMENT OF THE ARMY

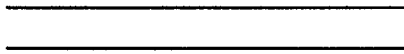

OFFICIAL BUSINESS

COMMANDER
U.S. ARMY TROOP SUPPORT COMMAND
ATTN: AMSTR-MMTS
4300 GOODFELLOW BOULEVARD
ST. LOUIS, MO 63120-1798

TEAR ALONG PERFORATED LINE

The Metric System and Equivalents

Linear Measure

1 centimeter = 10 millimeters = .39 inch
 1 decimeter = 10 centimeters = 3.94 inches
 1 meter = 10 decimeters = 39.37 inches
 1 dekameter = 10 meters = 32.8 feet
 1 hectometer = 10 dekameters = 328.08 feet
 1 kilometer = 10 hectometers = 3,280.8 feet

Weights

1 centigram = 10 milligrams = .15 grain
 1 decigram = 10 centigrams = 1.54 grains
 1 gram = 10 decigrams = .035 ounce
 1 dekagram = 10 grams = .35 ounce
 1 hectogram = 10 dekagrams = 3.52 ounces
 1 kilogram = 10 hectograms = 2.2 pounds
 1 quintal = 100 kilograms = 220.46 pounds
 1 metric ton = 10 quintals = 1.1 short tons

Liquid Measure

1 centiliter = 10 milliliters = .34 fl. ounce
 1 deciliter = 10 centiliters = 3.38 fl. ounces
 1 liter = 10 deciliters = 33.81 fl. ounces
 1 dekaliter = 10 liters = 2.64 gallons
 1 hectoliter = 10 dekaliters = 26.42 gallons
 1 kiloliter = 10 hectoliters = 264.18 gallons

Square Measure

1 sq. centimeter = 100 sq. millimeters = .155 sq. inch
 1 sq. decimeter = 100 sq. centimeters = 15.5 sq. inches
 1 sq. meter (centare) = 100 sq. decimeters = 10.76 sq. feet
 1 sq. dekameter (are) = 100 sq. meters = 1,076.4 sq. feet
 1 sq. hectometer (hectare) = 100 sq. dekameters = 2.47 acres
 1 sq. kilometer = 100 sq. hectometers = .386 sq. mile -

Cubic Measure

1 cu. centimeter = 1000 cu. millimeters = .06 cu. inch
 1 cu. decimeter = 1000 cu. centimeters = 61.02 cu. inches
 1 cu. meter = 1000 cu. decimeters = 35.31 cu. feet

Approximate Conversion Factors

To change	To	Multiply by	To change	To	Multiply by
inches	centimeters	2.540	ounce-inches	newton-meters	.007062
feet	meters	.305	centimeters	inches	.394
yards	meters	.914	meters	feet	3.280
miles	kilometers	1.609	meters	yards	1.094
square inches	square centimeters	6.451	kilometers	miles	.621
square feet	square meters	.093	square centimeters	square inches	.155
square yards	square meters	.836	square meters	square feet	10.764
square miles	square kilometers	2.590	square meters	square yards	1.196
acres	square hectometers	.405	square kilometers	square miles	.386
cubic feet	cubic meters	.028	square hectometers	acres	2.471
cubic yards	cubic meters	.765	cubic meters	cubic feet	35.315
fluid ounces	milliliters	29.573	cubic meters	cubic yards	1.308
pints	liters	.473	milliliters	fluid ounces	.034
quarts	liters	.946	liters	pints	2.113
gallons	liters	3.785	liters	quarts	1.057
ounces	grams	28.349	liters	gallons	.264
pounds	kilograms	.454	grams	ounces	.035
short tons	metric tons	.907	kilograms	pounds	2.205
poundfeet	newton-meters	1.356	metric tons	short tons	1.102
pound-inches	newton-meters	.11296			

Temperature (Exact)

°F	Fahrenheit temperature	5/9 (after subtracting 32)	Celsius temperature	°C
----	------------------------	----------------------------	---------------------	----

